

The Characteristics of Recycle Plaster of Paris at Different Drying Temperatures

Ainun Fathiah Hamdan¹, O H Hassan², N N Awang¹

¹College of Creative Arts, Universiti Teknologi MARA Perak Branch, 32610 Seri Iskandar Campus Perak, Malaysia, ²College of Creative Arts, Universiti Teknologi MARA Shah Alam, 40450 Shah Alam, Selangor, Malaysia, ³Green Safe Cities (GreSAFE), Faculty of Architecture, Planning, & Surveying, Universiti Teknologi MARA Perak Branch, 32610 Seri Iskandar Campus, Perak, Malaysia

Email: oskar@uitm.edu.my, nnazida@gmail.com

Corresponding Author Email: ainunfathiahh@gmail.com

To Link this Article: <http://dx.doi.org/10.6007/IJARBSS/v13-i9/16138> DOI:10.6007/IJARBSS/v13-i9/16138

Published Date: 18 September 2023

Abstract

The industry ceramic represents a large solid waste dumping and concerning environment damaged cause. As we know in Malaysia, ceramic industry very famous especially in Kuala Kangsar, Perak. According to Nawi (2016) the Department of Environment (DOE), 337,770 metric tons of plaster of Paris became solid waste in 2012, up from 80,000 metric tons in 2009. This shows an increase in solid waste is increasing. In this way, the aim of this study is to identify the chemical and physical properties that the used Plaster of Paris (POP) can be recycled as new plaster without affecting their casting performance. This paper showed the comparing the characteristic properties of New Plaster of Paris (NPOP) and Recycle Plaster of Paris (RPOP) at differences drying temperature. This experimental started with recycle used mould, crushing, sieving, drying in oven at variation temperature (150°C,160°C,170°C,180°C, 190°C) for 1 hour and tested with setting times, particle size, absorption test, porosity, and used the same ratio 40% of water and 60% material during the mixing process. The result show that all sample Recycles Plaster of Paris at variation temperature are performance and can be working similar New Plaster of Paris.

Keywords: Recycle Plaster of Paris (RPOP), Casting, Temperature, Drying

Introduction

Recycling is the collection of waste or rubbish to be reused as a new product through several processes. The first recycling process is collection and processing. Collection of this material through the curbside collection, drop-off centres, and refund programs. There are many products are being manufactured with recycled content. For example, through household items, industry sector, agriculture sector and others as reported by (Yang, 2011). Paul's Rubbish (2019) discussed recycling, feeding animals, biological reprocessing, incinerating

trash, and landfill are the five types of waste disposal procedures available. Recycling one of the processes from reusable waste through several manufacturing processes to make new products. In Malaysia, there are landfills, but not all of them can manage solid waste perfectly. Dumping of wastes in open fields and rivers is common even until today and a study of waste disposal behaviour in Kuala Lumpur indicated that 31.9% of waste was disposed of by open burning, while 6.5% were dumped into the river system.

Plaster of Paris (POP) or Calcium Sulfate Hemihydrate is a white powder that will harden when reacted with water. The name POP comes from Montmartre in Paris District where this material was first discovered and mined on a large scale. Through Britannica, (2019). POP is a white powder that will harden when reacted with water. POP when added to water, becomes a more soluble form of calcium sulphate returns to the relatively insoluble form, and heat is produced $\text{CaSO}_4 \cdot 1/2\text{H}_2\text{O}$. The setting of unmodified plaster starts about 10 minutes after mixing and is complete in about 45 minutes.

This problem continues to be proven through Badarulzaman, (2015) in Johor ceramic industry has recorded 20,000 tons of plaster of paris have been disposed every month. This amount is influenced by the production life cycle mould, which is only used 150-230 times, and when enough life cycle moulds are disposed of in landfill. According to Nawi (2016) the Department of Environment (DOE), 337,770 metric tons of plaster of Paris became solid waste in 2012, up from 80,000 metric tons in 2009. This shows an increase in solid waste is increasing. This problem is not only in Malaysia, but also in Brazil, 5400000 tons of gypsum plaster from construction and demolition waste into solid waste and this number could be greatly increased due to the lack of data control related to gypsum plaster waste as mentioned by (Gladis, 2015).

Through Parmar AJ, (2014) RPOP was formed by process heating of gypsum above approximately 150°C partially dehydrates the mineral by driving off exactly 75% of the water contained in its chemical structure. The partially dehydrated mineral is called calcium sulfate hemihydrate or commonly known as POP. The dehydration begins at approximately 80°C and the heat energy delivered to the gypsum at this time tends to go into driving off the water (as water vapor) rather than increasing the temperature of the mineral, which rises slowly until the water is gone, then increases more rapidly.

Through Pinheiro & Camarini (2015) gypsum plaster waste will recycle by 3 recycle cycles as show as in Fig 1. In the initial process before obtaining recycled plaster powder, pieces of Plaster waste will be a grinder and crushed in a ball mill less than 1.10 fineness modulus. The temperature used for drying was 150°C for 1 Hour. Geraldo (2017), reported that the process starts by drying the waste plaster block under the sun to reduce the water in the block. Crush in a hammer mill and sieve using 0.297MM, then dry the powder in an oven for $150^\circ\text{C}/1$ Hour, repeating the process three times. Although this process was performed repeatedly, the characteristics Although this process was performed repeatedly, the characteristics of the Recycle Gypsum plaster show a smaller particle size than the commercial plaster.

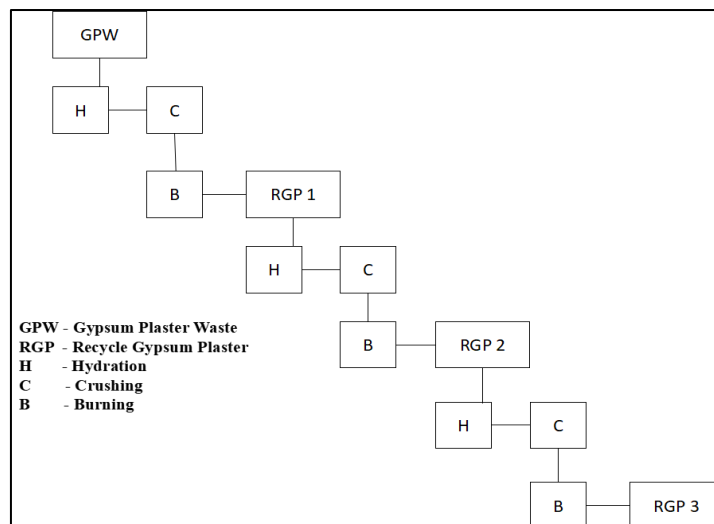

Fig.1 Recycling cycles CGP

Methodology

The materials used in this experimental work are New Plaster of Paris (NPOP) as a comparison guide or control to perform all the tests done and Recycle Plaster of Paris recycled gypsum plaster, obtained by grinding and drying the mould waste. Using an agitator, a 40% water and 60% of powder NPOP and RPOP ratio of ceramic powder to water was formed, and the slurry was left to set up. However, the length of time depends on the RPOP drying temperature and how long it is aged after being left alone for 24 hours.

Process of Recycle Plaster of Paris (RPOP)

This preparation is required to the purpose of crushed old mould because of the original nature of POP is a fine powder the powder POP obtained from the Perbadanan Kemajuan Kraftangan Malaysia Perak Branch, and the RPOP was manufactured by crushing, sieving, and drying in a dryer for one cycle. Using an agitator, a 40:60 ratio of ceramic powder to water was formed, and the slurry was left to set up. However, the length of time depends on the RPOP drying temperature and how long it is aged after being left alone for 24 hours. To achieve a constant powder size, the applied RPOP powder is sieved through a screen with a mesh size 1.25MM. The fine powder will be dried for 1 hours at 37°C,150°C,160°C,170°C,180°C,190°C in the dryer. Drying is carried out to reduce or eliminate the water content in the applied POP powder.

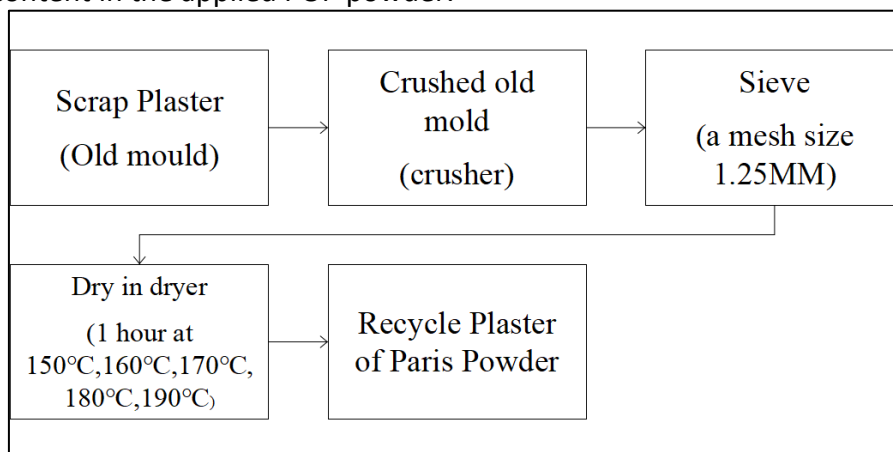

Fig.2 Process Recycle Plaster of Paris (RPOP)

Sample Preparation

Sample mould recycle plaster of paris that had been prepared by using powder recycle plaster of paris which has been dry in dryer for several temperature (37°C,150°C,160°C,170°C,180°C and 190°C) and mix with water will be mixed with water for the plaster to harden. To equally spread the water's surface, plaster is poured into the container and sifted through a spoon. The ratio for mixture this sample was 40g of water and 60g of material NPOP or RPOP. In this experiment had 7 samples while be test which is given in Fig 3.

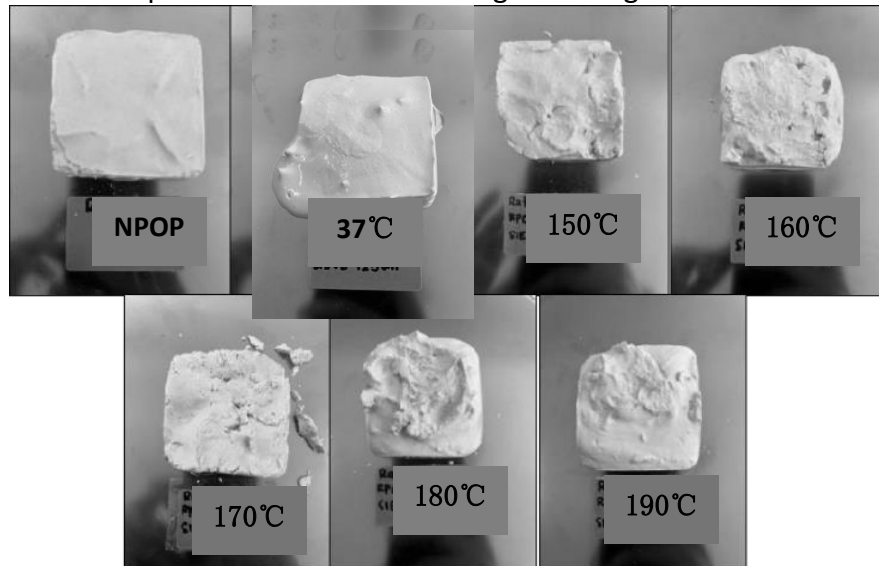

Fig.3 Sample NPOP and RPOP (37°C,150°C,160°C,170°C,180°C,190°C) after setting

Characterization Test

Using the CILAS particle size analyses to determine the particle size of Recycle Plaster of Paris after the sieving for 1.25(μm). Compressive strength analyses be tested by using Compressive Strength Testing Machine (ASTM Standard). Give all the samples in the laboratory for determining its hardness, compressive strength, porosity, absorption sample size is 40mm×40mm×40mm in solid shape.

Porosity of sintered samples were measured by using Metter Toledo density Kit following Archimedes principle (ASTM 372). Nawi (2016), porosity and bulk density was used calculation by the Archimedes' principle as show as in below.

$$Porosity = \frac{W_w - W_d}{W_d - W_s} \times 100\%$$

Whereas:

W_d = mass of air dried specimen (mg)

W_s = mass of immersed specimen in liquid (mg)

W_w = mass of immersed specimen in air (mg)

Water absorption is used to determine the amount of water absorbed under specified conditions. Factors affecting water absorption include type of material, temperature and length of exposure. In this test, the samples had dimension of 10cm×2cm×2cm.

Result and Discussion

Particle Size Analyses

Table 1 showed, there are measurements of particle size distribution at 60% point of the cumulative value. It shows that the largest size at 60% point is 34.094 μm meanwhile the lowest at the point of is 7.707 μm . Therefore, it has been proven that the particle size distributions are in the range of bigger than 1.25 μm . Therefore, NPOP is observed as a control, at a temperature of 180°C, the particle size distribution is closest to NPOP when compared to the others.

Table 1

Particle size distribution of NPOP powder and RPOP

Particle size (μm)	Sample °C	Cumulative value	Particle Size distribution (μm)
1.25 μm	NPOP	D60	11.066
	RPOP 37°C		34.094
	RPOP 150°C		29.485
	RPOP 160°C		22.781
	RPOP 170°C		26.634
	RPOP 180°C		10.548
	RPOP 190°C		7.707

Compressive Strength

The data Fig 4 shown the result of compressive strength at a drying temperature of 150°C are large using a ratio of 40:60 has a compressive strength of 12.8047 kN. While at a temperature of 170°C compressive strength is 3.98828 kN which recorded the lowest amount. However, the compressive strength starts to rise once more at 180°C and continues to rise until 190°C. This is affected by the amount of water present and the temperature at which RPOP is mixed and dried. Through Li et al., (2018), gypsum has dehydration characteristics and different physical properties in addition to hemihydrate activity also depending on the preparation temperature. The findings of the compressive strength thus demonstrate that at a temperature of 150 °C, the result is almost the same as NPOP. At a temperature of 150 °C, extracting water from the moderate recycling process increases the water content in the RPOP mixture during mixing and increases its density.

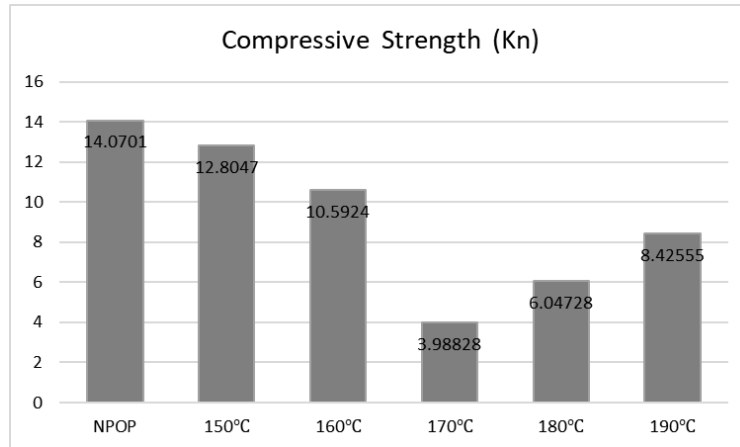

Fig 4. Compressive strength at Different Drying Temperature

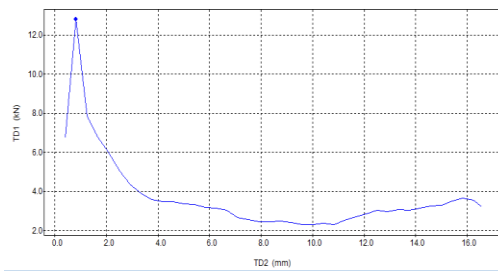

Fig 5. Compressive strength NPOP

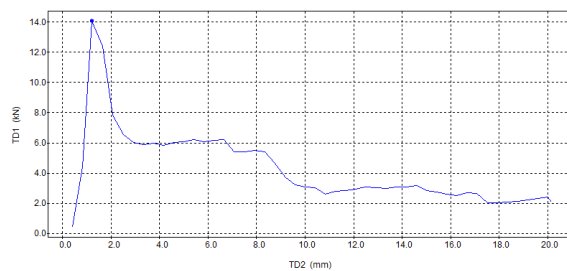

Fig 6. Compressive strength 150°C RPOP

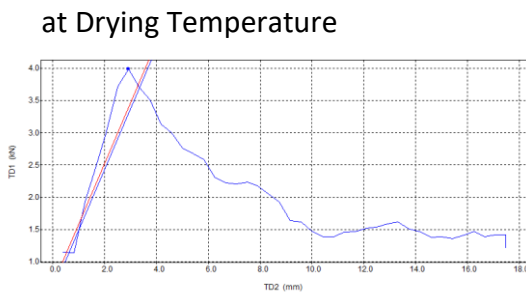

Fig 7. Compressive strength 160°C RPOP at Drying Temperature

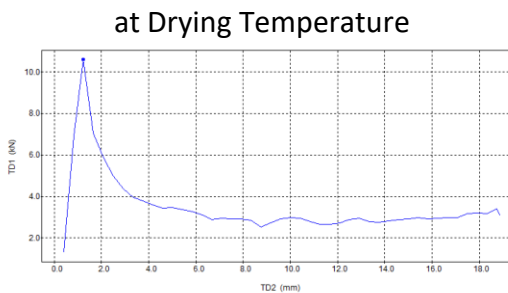

Fig 8. Compressive strength 170°C RPOP at Drying Temperature

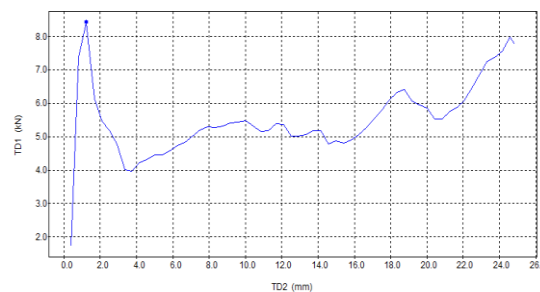

Fig 9. Compressive strength 180°C RPOP at Drying Temperature

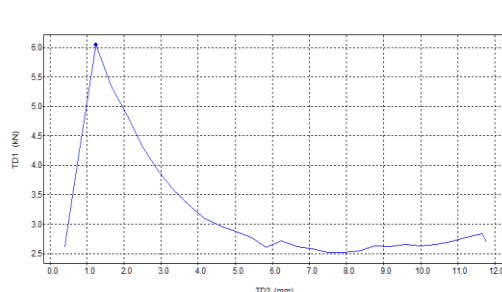

Fig 10. Compressive strength 190°C RPOP at Drying Temperature

Porosity

The percentage of porosity for NPOP and RPOP at various drying temperatures is shown in Fig. 11. According to the graph plot, RPOP 180°C has a lesser porosity percentage of 144% whereas RPOP 160°C has a larger percentage of 157%. Reported by A Mat Nawi and N.A.Badarulzaman, (2015), the percentage of porosity decrease may happen because in each sample that is studied the number of void space porosity decreases which is affected by the temperature used. This analysis proves that the control sample in this study, 160°C, is nearly identical to NPOP.

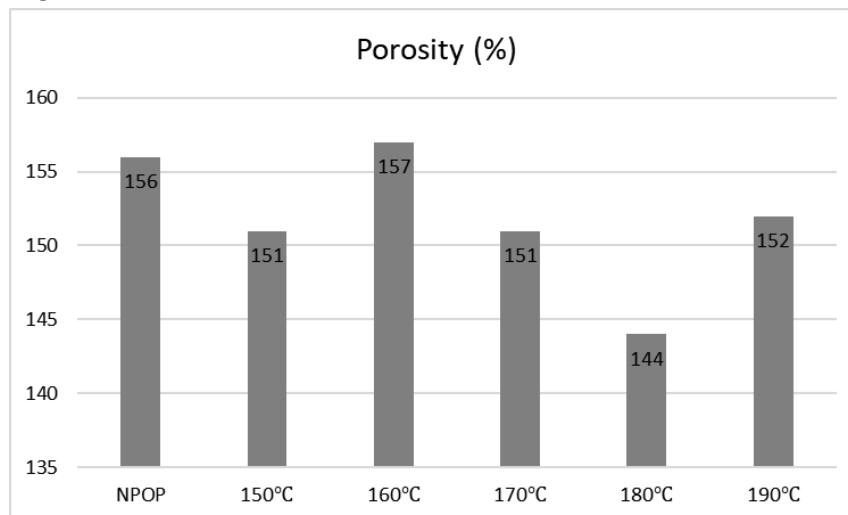

Fig 11. Percentage of porosity at Different Drying Temperature

Water Absorption

The sample was dried for 4 hours at a temperature of 55°C before water absorption was test. The percentage of absorption decreases on every sample, as shown in Fig. 12. This is because different drying temperatures can have an affect on it. Therefore, even though the ratio of water to RPOP powder is constant, the percentage of water absorption decreases as the temperature was increased. According to, M.J. Madu (2016), the increase in hardness in plaster of paris is caused by the quantity of water used. When the volume of water increases, the fraction of voids will also increase while the bonds between particles will decrease causing the strength of the sample to be low.

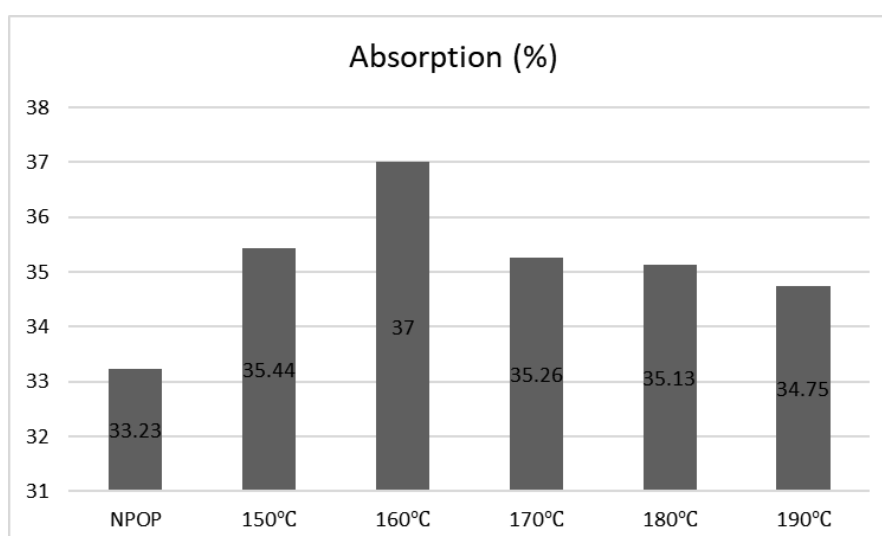

Fig 12. Percentage of water absorption

SEM Test

Fig 14 shows scanning electron microscope (SEM) images of NPOP and RPOP plaster powders. From Fig. 1(a) NPOP, it is clear the surface has very few pores and that the components' crystallinity was unclear. However, there are many crystal clusters and interwoven crystals with rather long radii on RPOP 37°C as shown on Fig 1(b). However, a change in crystal shape occurs when RPOP powder is dried at a temperature 150°C, 160°C, 170°C, 180°C and 190°C. The crystal radius is getting longer and bigger, while the pores on the surface are growing. The structure of RPOP powder will change during recycle process. Crystals become decrease and the amount of water required to maintain the workability of the recycled plaster slurry may increase and may lead to a decrease in the strength of the recycled plaster. This is more obvious when Sayonara, Pinheiro and Gladis Camarini, (2015) reported that the additional information to determine the chemical components of gypsum includes the amount of free water, the degree of water crystallization, calcium oxide, and sulfur contained in plaster of paris.

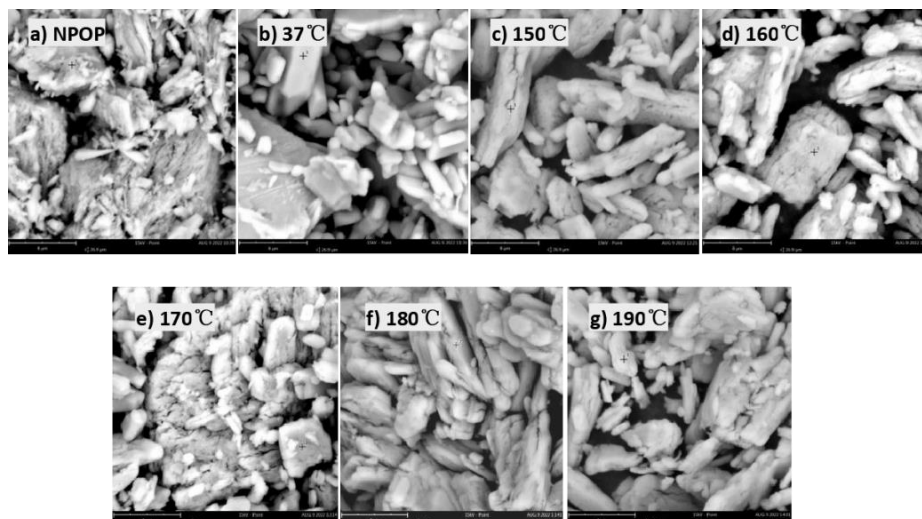

Fig 14 The microstructure of powder (a) NPOP ,(b) 37°C, (c) 150°C, (d) 160°C, (e) 170°C,(f) 180°C and (g) 190°C

XRD Test

The XRD patterns of NPOP and RPOP are given in Figure 15. Similarities between sorts of NPOP and RPOP at different drying temperatures at 37°C, 150°C, 160°C, 170°C, 180°C, 190°C are often observed because almost the identical XRD patterns are obtained. Additionally to the NPOP gypsum sample (Ref # 024-1067) peak, the XRD peak of dolomite (Ref # 036-0426) was observed in all samples, within the results that observed the Bassanite content was low (Ref # 024-1067) which could indicate some content aggregates or additives to control the pH of gypsum. Altogether RPOP samples, no aggregate phase was observed and only gypsum peaks. If observed the XRD patterns of all samples are the identical, there's a component of gismondine (Ref # 024-1067) as shown within the XRD. Gismondine could be a calcium aluminum silicate hydrate that will be formed in an exceedingly high and continuous aluminosilicate composition within the presence of calcite, and gypsum. Gismondine can give extra strength to ingredients. Gismondine can give extra strength to the material. In addition, the results show that at NPOP and RPOP drying temperature at 150°C to 190°C there's the appearance of Bassanite. Briefly, the

appearance phase of bassanite occurs at a temperature of 150 to 190°C which can appear at high temperatures. According to Hamer, (2004) and Taylor & Bull, (1986), quartz is heated and its structure will change to polymorph silicon dioxide (SiO₂) which is different between the temperatures for tridymite at 800 to 1000°C but it converts only a little amount of quartz to cristobalite because cristobalite is more readily forms at 1400°C and reaches its maximum around 1800°C.

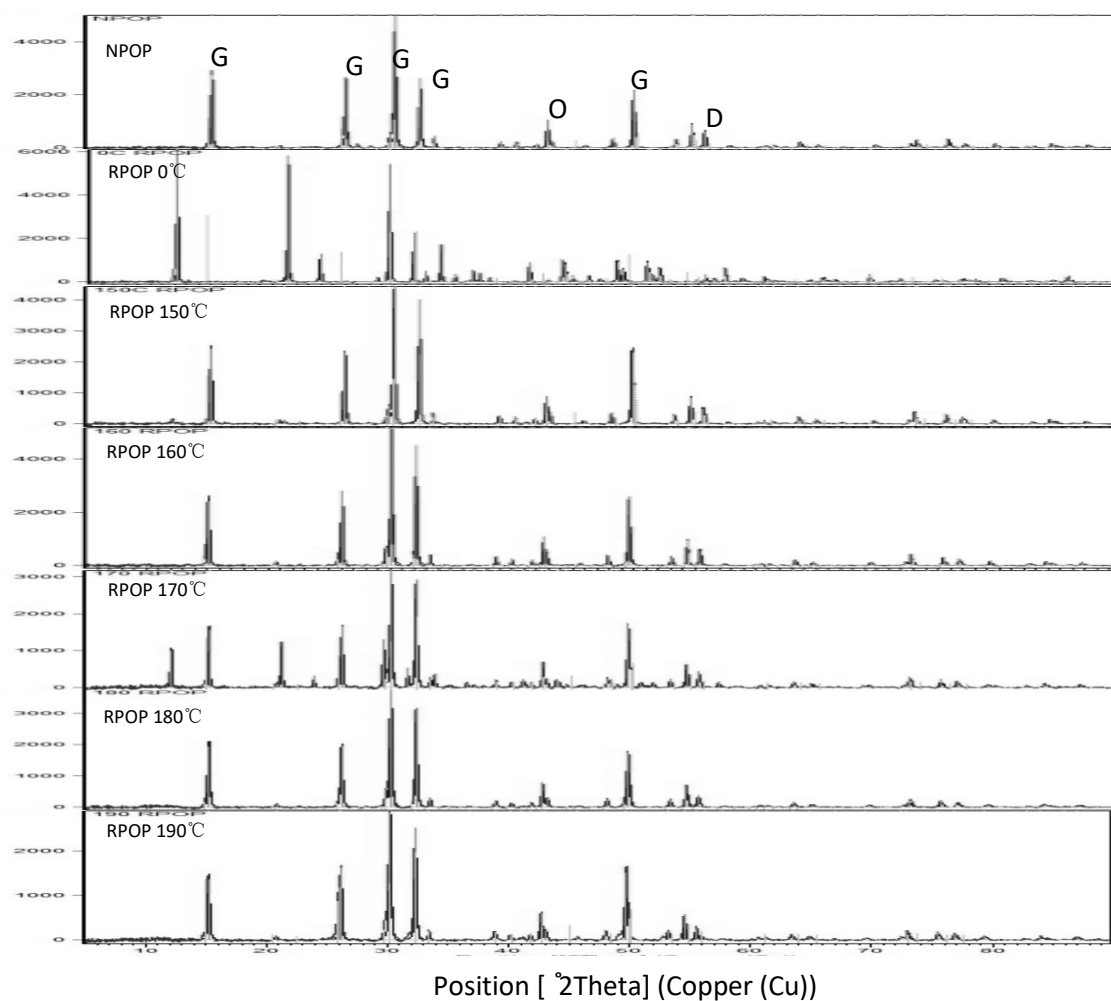

Fig 15 XRD results of different types of temperature of plaster of Paris, NPOP- New Plaster of Paris, 37°C, 150°C, 160°C, 170°C, 180°C, 190°C, standard. G—gypsum $\text{CaSO}_4 \cdot 2\text{H}_2\text{O}$, o—Gismondine, $\text{CaAl}_2\text{Si}_2\text{O}_8 \cdot 4\text{H}_2\text{O}$

Conclusion

According to research, his study shows that RPOP is recyclable and may be utilized to produce mould casting as well as through the recycling process. The use of various temperature (150°C, 160°C, 170°C, 180°C, 190°C) for 1 hour gives the result that all these temperatures can be used in the recycle process, however, this study show that the RPOP can be recycled at optimum temperature 160°C for the same purpose than the original binder. Thus, this study shows that RPOP is recyclable through the recycling process. RPOP 160°C has the same physical and chemical characteristics as NPOP, although it has a different fineness and particle

size distribution. If it is moulded into a mould, RPOP can still carry out the same process as NPOP. High levels of calcium sulphate hemihydrate ($\text{CaSO}_4 \cdot 0.5\text{H}_2\text{O}$) are found in all samples. In addition to keeping the primary features of NPOP, the addition of calcium sulphate hemihydrate to RPOP has increased the binding qualities of RPOP. Thus, this study shows that RPOP is recyclable through the recycling process.

References

- NAWI, A. B. (2016). EFFECT OF WASTE PLASTER OF PARIS ON PHYSICAL AND MECHANICAL. 2-4.
- Paul's Rubbish. (2019). *5 Types of Waste Disposal Methods - Paul's Rubbish Removal*. <https://www.paulsrubbish.com.au/5-types-of-waste-disposal-methods>
- Madu, M. J., Ndaliman, M. B., Oche, B. (2010) Evaluation of Water-to-Plaster Ratio on Products of Nafada Plaster of Paris (POP, Volume 4, Issue 10, PP 23-27
- Yang, Y., Boom, R., Irion, B., Heerden, D. V., Kuiper, P., & Wit, H. de. (2011). Recycling of composite materials. *Chemical Engineering & Processing: Process Intensification*. <https://doi.org/10.1016/j.cep.2011.09.007>
- Britannica. (2019). Gypsum : Definition, Uses, & Facts. *T. Editors of Encyclopaedia*. <https://www.britannica.com/science/gypsum>
- Nawi, A. M., & Badarulzaman, N. A. (2015). Effect of plaster of Paris waste and sintering temperatures on physical properties of pottery. *Procedia CIRP*, 26(December), 752–755. <https://doi.org/10.1016/j.procir.2014.08.019>
- Camarini, G., Pinto, M. C. C., Moura, A. G. de, & Manzo, N. R. (2016). Effect of citric acid on properties of recycled gypsum plaster to building components. *Construction and Building Materials*, 124, 383–390. <https://doi.org/10.1016/j.conbuildmat.2016.07.112>
- Pinheiro, S. M. M., & Camarini, G. (2015). Characteristics of Gypsum Recycling in Different Cycles. *International Journal of Engineering and Technology*, 7(3), 215–218. <https://doi.org/10.7763/ijet.2015.v7.794>
- Parmar AJ, Tyagi SK, Dabas VS, Mistry JN, Jhala SK, Suthar DN, Bhatt RH, Pansuria DV, Bhatti IM (2014) Assessment of the physical and mechanical properties of plaster of Paris bandage cast used as a splinting and casting materials, *Veterinary World* 7(12): 1123-1126.