

NATKAP: An Innovation of Oil Trap for Cage Fish Farming Using Kapok-Based Adsorbents

Mohammad Abdullah¹, Norhafini Hambali¹, Mohd Zaki Sukor¹, Wan Nur Fazlina Abdol Jani¹, Nurul Hazwani Sabri¹, Ab Aziz Mohd Yusof², Azizul Hakim Samsudin², Diana Che Lat³ and Juliana Martin³

¹Chemical Engineering Studies, College of Engineering, Universiti Teknologi MARA Johor Branch, Pasir Gudang Campus, Johor, Malaysia, ²Mechanical Engineering Studies, College of Engineering, Universiti Teknologi MARA Johor Branch, Pasir Gudang Campus, Johor, Malaysia, ³Civil Engineering Studies, College of Engineering, Universiti Teknologi MARA Johor Branch, Pasir Gudang Campus, Johor, Malaysia.

To Link this Article: <http://dx.doi.org/10.6007/IJARBS/v13-i11/19626> DOI:10.6007/IJARBS/v13-i11/19626

Published Date: 22-11-2023

Abstract

Most of the cage fish farms today are located in river courses close to industrial areas and also urban areas. Therefore, this farming is exposed to the danger of pollution from oil spills, dyes, dissolved chemicals and so on. Solutions need to be taken to overcome this problem because this pollution can cause the deterioration of the quality of farmed fish, water pollution in the cage and even the death of the fish in the cage. NATKAP is an innovation of trapping oil and suspended river waste for fish cages by using Kapok absorbent material. Kapok was chosen as a dirt absorbent material because it has a high ability to trap dirt such as oil and so on. The results of this study show that 98.93% of the oil can be absorbed by the Kapok material. In addition, the use of Kapok also improves the quality of river water in cage fish farming areas. Kapok morphology structure that absorbs watery dirt is found to expand and appear brighter. Therefore, the result of NATKAP's innovation is very suitable for use as a filter material for fish cages because Kapok, which is the adsorbent material, is able to remove suspended oil at a high percentage and also improve the quality of river water.

Keywords: NATKAP, Oil Removal, Cage Fish Farming, Kapok, Absorbent, Natural Sorbent.

Introduction

NATKAP is a development of an innovative oil trapping product that will be applied to fish cages in river fish farming areas. The word NATKAP is a combination of NAT which refers to "natural" and KAP refers to Kapok. This product was developed following the occurrence of oil pollution in Pasir Gudang waters caused by oil spills from ships, industrial areas, institutions, housing and tourism areas (Ismail et al., 2020). Oil spill problems often occur at

the river area around Pasir Gudang due to the rapid manufacturing sector, docked ships and eco-tourism activities.

There are many cage fish farming companies in Malaysia such as in the states of Pahang, Selangor, Kelantan, Perak, Terengganu, Penang, Sabah, Sarawak and Johor (Hamdan et al., 2015). This cage fish farming enterprise is usually carried out in open river and estuary areas which are also close to industrial areas and villages. As a result, these farmed fish are easily exposed to various waste water pollution brought from industrial areas, shipping and villages. Waste water pollution among them is factory sewage waste, chemical waste, color waste, heavy metal waste, village sewage waste, ship oil waste and so on (Ferronato & Torretta, 2019). This suspended waste can have a harmful effect (Lin et al., 2022) on cage fish farming as well as reduce the quality of the fish kept in the cage. From this suspended waste, floating oil waste is a big problem for cage fish farming because this oil waste can cover the surface of the water and further affect the health of the fish (Abdullah et al., 2016).

Therefore, in this study it has been proposed to trap suspended waste such as oil around the fish cage at Selat Mendana, Kong Kong Laut. The adsorbent material used for this filter is from a natural source which is Kapok or its scientific name is *Ceiba pentandra*. Kapok was chosen as the basic material for absorbing oil in this study because of its special properties that prefer oil, i.e., oleophilic, and its properties that do not absorb much water, i.e., hydrophobic (Abdullah et al., 2019). The innovation of oil traps for fish cages that use natural materials as adsorbents can have a good effect on the results of cage fish farming as well as reduce oil pollution floating in river water.

Methodology

Materials

Sodium hydroxide (SYSTEM, Malaysia) with molecular weight 39.997 and 99.0% purity. Hydrochloric acid (Fisher, Malaysia) with molecular weight 36.46 and 99.0% purity. Kapok (*Ceiba pentandra*) was bought from the local supplier.

Adsorbent Preparation for NATKAP-Oil Trap System

Kapok is first cleaned using distilled water and then soaked in 1.0 M Sodium hydroxide for 24 hours at room temperature. The main purpose of Kapok soaked in sodium hydroxide is to remove lignin and impurities still attached to the fiber. After 24 hours, the Kapok was cleaned by soaking it in a container filled with distilled water and rinsing until clean. Kapok is then immersed in a hydrochloric acid solution with a concentration of 0.3 M to neutralize the Kapok that has been treated with sodium hydroxide. After being rinsed back with distilled water, the Kapok is dried for 24 hours and then put in the oven at a temperature of 60°C for 30 minutes (Shah et al., 2019).

Preliminary Oil Evaluation Test

The percentage of oil removal was conducted (Figure 1) by soaking the Kapok in vegetable oil waste for at least 15 minutes. The percentage of oil removal was calculated using equation below (Shah et al., 2019).

Percentage of oil removal (%) = (Final weight – initial weight) / initial weight

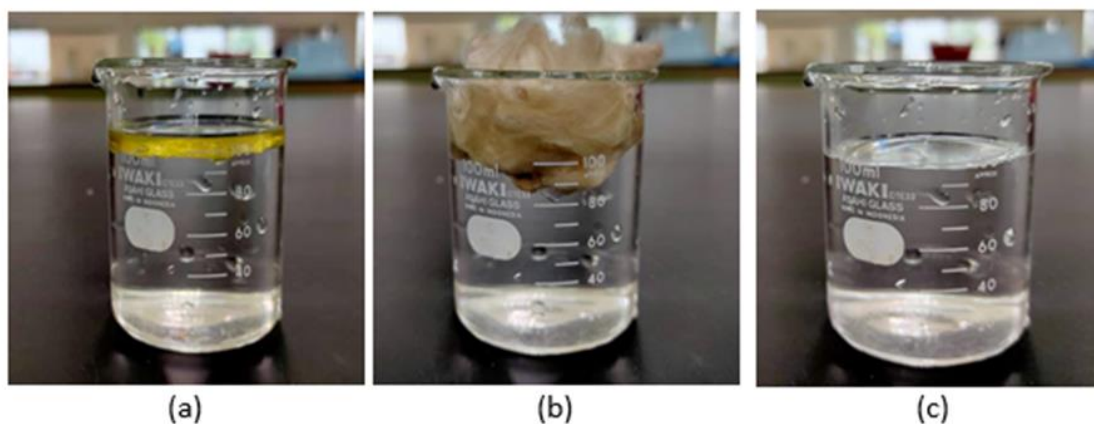

Figure 1. Diagrams the flow of oil evaluation test using Kapok (a) pour the vegetable oil into the beaker with water (b) Soaking the Kapok fibre (c) After 15 minutes, remove the soaked kapok and the water is clean again

Preliminary Water Quality Test

The quality of river water in the cage area has been studied by conducting several water quality tests such as pH, temperature, turbidity, total dissolved solid (TDS), conductivity, salinity, chemical oxygen demand (COD) and biological oxygen demand (BOD).

Scanning Electron Microscopy (SEM)

The sample was shifted on SEM stub and sizzled with Platinum/pt. Morphologies of the Kapok fibre were observed using JSM-6390LV scanning electron microscope (JEOL, Japan) in the magnification range of 500 X at room temperature.

Result and Discussion

Proposed NATKAP Design

This study involves the cage fish farming area in the Kong Kong Laut area, Pasir Gudang as shown in Figure 2. NATKAP- this suspended material filter is 10ft x 8ft in size which will be installed around the fish cage as in Figure 3. This filter is made of PVC pipe and placed in this filter is an absorbent material which is Kapok. This filter is made with small pores on its surface so that oil or suspended matter in the river can be filtered and absorbed by the adsorbent.



Figure 2. Cage fish farming area, Kong Kong Laut, Pasir Gudang, Johor, Malaysia.

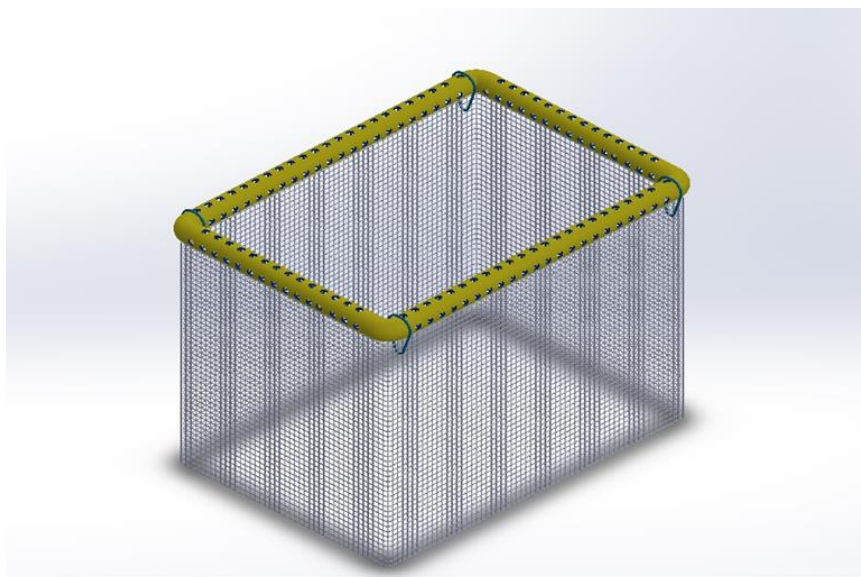

Figure 3. Schematic diagram for the proposed innovation filter – NATKAP

This filter is proposed to be installed in cage fish farming areas to reduce the risk of river pollution that often occurs due to oil spills from industrial areas and the shipping sector (Abdullah et al., 2021).

Oil Evaluation and Water Quality Test using Kapok as Adsorbent

In this study, the evaluation of the efficiency of Kapok adsorbents against oil absorption was carried out using used vegetable oil. Table 1 has shown the percentage of oil removed by using Kapok. As a result, the average of percentage removal of oil using kapok was 98.93% with standard deviation 0.29. This high percentage shows that Kapok's ability to absorb oil in river water. Previous study by Shah et al (2019) using Kapok in removing oil onto the floor was about 66.15% removal. These results show that Kapok is more effective when used in water than on the floor as an adsorbent.

There are eight parameters (Table 2) that have been measured to see the quality of the river water in the cage at six points such as pH, temperature, turbidity, salinity, conductivity, total dissolved solids, COD and BOD using Kapok as adsorbent material. From this observation, the pH and temperature values for the six points are almost the same, indicating that the river water in the area is suitable for cage fish farming. Total dissolved solid (TDS) and conductivity measurement have shown relatively high values, this indicates that there is a content of suspended waste in the cage fish farming area (Rusydi 2018). As the conductivity increased the salinity value also increased (Hasan et al., 2023). Meanwhile, the turbidity value is almost the same for each point showing the equivalence of river water flow in the area concerned. The turbidity of river water depends on the tidal factor of sea water and also the waste carried by factories and so on (Tien et al., 2020). The COD and BOD values show that the level of pollution in the cage fish farming area is moderate. This is likely due to the tidal factor of the river which constantly flows water from one area to another.

Scanning Electron Microscopes (SEM)

Images of SEM (Figure 4), demonstrated the surface morphology of Kapok fibre before and after the absorption of water. The surface of kapok looks smoother before the absorption of river water, while after the water absorption process, the surface of kapok looks slightly expanded. This has shown that there are liquid elements that have absorbed in this Kapok material.

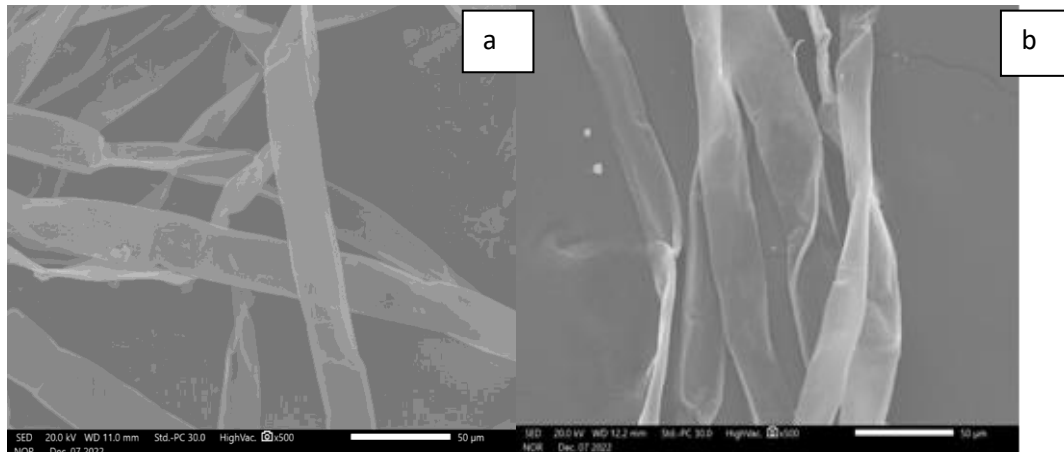

Figure 4. SEM image at 500X of Kapok fibre before and after absorption of water

Table 1
Percentage of vegetable oil waste removal using Kapok

Item	1 st Reading	2 nd Reading	3 rd Reading	Average	SD
	98.5%	99.3%	99.0%	98.93%	0.29

Conclusion

The innovation of the suspended waste filter in the cage fish farming area shows that it is very necessary to reduce water pollution in the farming area. Based on the findings, the absorption of suspended oil is over 95% and it is very suitable for use. Apart from that, the water quality readings also show that Kapok is suitable for use as an adsorbent. Therefore, this NATKAP innovation can provide a new method in the process of trapping suspended waste in open river areas.

Table 2

Table: Water quality parameter for Fish Cage Farming at Selat Mendana, Kong Kong Laut, Pasir Gudang

Parameter	S1	S2	S3	S4	S5	S6
pH	8.18	8.51	8.57	8.67	8.71	8.74
Temperature (°C)	11.9	12.1	12.7	12.8	13.0	13.1
Conductivity (µsv)	882	678	759	773	788	824
Total Dissolved Solid (PPM)	150	144	156	153	162	166
Salinity (PPM)	2475	2300	2388	2213	2263	2413
Turbidity (NTU)	8.98	8.56	7.92	7.86	8.23	8.50
Chemical Oxygen Demand (COD)	72	123	19	87	124	160
Biological Oxygen Demand (BOD)	4	4.11	3.7	4.08	3.69	3.7

Acknowledgement

The authors would like to say thank you to all staff at the Studies of Chemical Engineering, College of Engineering, Universiti Teknologi MARA, Johor Branch, Pasir Gudang Campus because give permission to use their laboratory and equipment. The appreciations also to the Universiti Teknologi MARA, Johor Branch because the sponsorship on the Geran Penyelidikan Inovasi Fasa 1 600-TNCPI 5/3/DDN (01) (033/2021).

Corresponding Author

Mohammad Abdullah

Chemical Engineering Studies, College of Engineering, Universiti Teknologi MARA Johor Branch, Pasir Gudang Campus, Johor, Malaysia

Email: moham3767@uitm.edu.my.

References

- Ismail, S. N. S., Abidin, Z. E., & Rasdi, I. (2020). A Case Study of Pasir Gudang Chemical Toxic Pollution: A Review on Health Symptoms, Psychological Manifestation and Biomarker Assessment. *Malaysian Journal of Medicine and Health Sciences*. 16(SUPP11): 175-184.
- Hamdan, R., Othman, A., & Kari, F. (2015). Climate Change Effects on Aquaculture Production Performance in Malaysia: An Environmental Performance Analysis. *International Journal of Business and Society*, 16 (3):364 – 385.
- Ferronato, N., & Torretta, V. (2019). Waste Mismanagement in Developing Countries: A Review of Global Issues. *Int. J. Environ. Res. Public Health*, 16(6), 1060; <https://doi.org/10.3390/ijerph16061060>.
- Lin, L., Yang, H., & Xu, X. (2022). Effects of Water Pollution on Human Health and Disease Heterogeneity: A Review. *Front. Environ. Sci.* 10: 880246.doi: 10.3389/fenvs.2022.880246.
- Oil/Water Absorption System. *Journal of Physics: Conference Series*, 1349, 012104.
- Shah, N. M. A. N., A., F., Abdullah, M., Saadun, M. A., A., Zaiton, S. N. A., Azman, H. A. Che Lat, D., Khalid, A. K., & Hambari, N. (2019). A Comparison Study of Carbonized Kapok Fibres Treated by Sodium Hydroxide Solution and Hydrochloric Acid Solution as an Absorbent in Removing Oil Waste. *IOP Conf. Ser.: Mater. Sci. Eng.* 551 012004.
- Abdullah, M., Azmi, F. A., N., Azahar, M., Z., Amri, M. F., N., Kadiran, K., A., Che Lat, D., Abu Kasim, H., & Khalid A., H. (2021). Application of Casuarina Equisetifolia needle for the removal of heavy and light oil waste. *AIP Conference Proceedings* 2339, 020156 (2021); <https://doi.org/10.1063/5.0044212>.
- Rusydi, A. F. (2018). Correlation between conductivity and total dissolved solid in various type of water: A review. *IOP Conf. Ser.: Earth Environ. Sci.* 118 012019.
- Hasan, M. F., & Abuel-Naga, H. (2023). Effect of Temperature and Water Salinity on Electrical Surface Conduction of Clay Particles. *Minerals*, 13(8), 1110. MDPI AG. Retrieved from <http://dx.doi.org/10.3390/min13081110>.
- Tien, N. N., Uu, D. V., Cuong, D. H., Mau, L. D., Tung, N. X., & Hung, P. D. (2020). Mechanism of Formation and Estuarine Turbidity Maxima in the Hau River Mouth. *Water*, 12(9), 2547. MDPI AG. Retrieved from <http://dx.doi.org/10.3390/w12092547>.