

## Higher Order Thinking Implementation Strategies in Teaching Listening and Speaking Skills of Malay Language Teachers in Primary School

Farah Aziana Abdul Aziz<sup>1</sup>, Fadzilah Abdul Rahman<sup>2</sup>, Shamsudin Othman<sup>3</sup>

Email: farah\_aziana@yahoo.com, dzila@upm.edu.my, s\_shamsudin@upm.edu.my  
Faculty of Educational Studies, Universiti Putra Malaysia 43400 Serdang, Selangor, Malaysia

To Link this Article: <http://dx.doi.org/10.6007/IJARBS/v10-i10/8059> DOI:10.6007/IJARBS/v10-i10/8059

**Published Date:** 26 October 2020

### Abstract

Higher Order Thinking Skills (HOT) is one of the key elements that are emphasized in the Malaysia Education Blueprint (MEB) 2013-2025 to improve the quality of the country's education which comparable with other countries. Most of Malay language teachers are facing shortage of HOT teaching strategies specifically in PdPc. In this regard, a study on HOT implementation strategy should be executed to address the gaps in the study of HOT. In this study, the research method used was qualitative since previous studies on HOT had used quantitative method. The method of direct observation of classroom teaching, semi-structured interviews and document analysis were used in this study. Specifically, this study covers four main objectives, which were to describe the implementation strategies of HOT in PdPc listening and speaking skills in Selangor Integrated Primary Religious School at the level of thought of applying, analyzing, evaluating and creating. The researchers used the case study research design, which the case on HOT implementation strategies in Malay language teachers' teaching listening and speaking skills at Integrated Primary Religious School. Six respondents were chosen from three different Integrated Primary Religious Schools, where they teach standard 5 Malay language, covering both urban and rural areas. Anderson and Krathwohl Bloom's Taxonomy Theory Revised (2001) and Robert Glaser's Teaching Model (1962) were used to answer each question in this study. The findings showed that out of 28 HOT strategies, 14 HOT implementation strategies occurred in PdPc listening and speaking skills. The results reported that almost all the six participants conducted HOT teaching started with the determination of the teaching objectives, which based on the existing knowledge of the students, the used of appropriate HOT teaching methods and the assessment of the well-conducted PdPc.

## **Introduction**

Kurikulum Bersepadu Sekolah Rendah (KBSR) is a part of education manifestation that emphasized on the thinking skills. Thinking skills were the core of learning which included the mental process or originated idea in PdPc (Isnon & Badusah, 2017). Malaysia Education Blueprint (MEB) 2013-2025 explained thinking skills as students need in order to be comparable and competitive globally. If thinking skills were enhanced inside the classroom, it could be an asset of excellence in student achievement (Kassim & Zakaria, 2015). Therefore, all parties involved directly or indirectly especially teachers need to prepare themselves with knowledge and skills in PdPc thinking skills in line with the needs of the 21st century (Ministry of Education, 2013; Ismail, 2014).

## **Problem Statement**

The study on HOT in language skills in general, had been widely executed. However, in the context of past studies differed from this study as the researchers will explore the HOT implementation at the level of apply, analyse, evaluate and create thought in PdPc skills of listening and speaking. Previous studies had described in general about the implementation of HOT in all four language skills. For example, the study of Isnon & Badusah (2017) was related to the HOT implementation in general in all four language skills.

The proficiency of HOT needed long duration of time to be mastered compared to the mastery of skills or knowledge in a subject which can be mastered through the experience of appropriate HOT implementation strategies in PdPc (Zakaria & Badusah, 2014). Thus, the implementation of HOT was trained early on, which from lower education in order to easily facilitate the acceptance process at the higher level as well as could minimize the students' confusion toward the implementation of HOT in PdPc (Arshad, 2016). HOT implementation strategies could smoothly work if teachers have broad knowledge about HOT and understand the way of implementing HOT in the subjects being taught (Muhammad & Ali, 2016). Therefore, this study focused on the implementation strategies of HOT specifically in teaching listening and speaking skills.

## **Research Objective**

1. Described the implementation strategies of HOT in Malay language teachers' teaching listening and speaking skills at the level of apply thought at SRAI Selangor.
2. Described the implementation strategies of HOT in Malay language teachers' teaching listening and speaking skills at the level of analyze thought at SRAI Selangor.
3. Described the implementation strategies of HOT in Malay language teachers' teaching listening and speaking skills at the level of evaluate thought at SRAI Selangor.
4. Described the implementation strategies of HOT in Malay language teachers' teaching listening and speaking skills at the level of create thought at SRAI Selangor.

## **Literature Review**

### **Higher Order Thinking Skill (HOT)**

Higher Order Thinking Skills was a demand in the development of Malaysian education according to the current trend in order to produce generation of higher order thinkers. HOT implementation in Malaysia is driven by the insistence of deterioration in Malaysian achievement in global testing such as PISA and TMSS effect from student's weakness which most of them only skilled at the level of

understanding and remembering. Higher Order Thinking (HOT) was the string of government efforts to produce the generation of out of box thinkers after Creative and Critical Thinking (CCT) was executed. In Malaysia, thinking skills was emphasized since 1994 and the emphasis on HOT was implemented after Standard Curriculum for Primary Schools (KSSR) in 2011 was introduced. (Ministry of Education, 2013).

According to Bloom's Taxonomy Review in 2001, HOT was referred to four stages of higher thinking, which were the level of apply, analyze, evaluate and create thought while LOT included the level of understanding and remembering (Ministry of Education, 2014; Sharuji & Nordin, 2017). HOT allowed someone to think critically and innovatively, solving problem, making decision in routine and non-routine activity, understanding, analyzing, and manipulating information in detail, in contrast with LOT, it involved the routine activity only (Ismail, 2014). Thus, the Malay language teacher's HOT implementing strategies in PdPc of listening and speaking skills among primary schools' students could be seen in four stages of higher thinking specifically.

### **Implementation of Higher Order Thinking (HOT) in Malay Language Subject**

The implementation of HOT in Malay language subject has been introduced but was not emphasized accordingly due to some teachers did not apply HOT in their teaching (Yussof, 2013). This was supported by the study of Ismail & Mahamod (2016), explained that HOT implementation was still poor due to the teacher's weakness in applying high level questions in the PdPc process to test the students level of thinking skills.

Teachers should be exposed to the knowledge and skills in their teaching area with proper thinking skills. This was supported by Ismail & Mahamod (2016), who stated that teachers who have strong teaching skills will implement teaching process effectively.

### **Strategy of Teaching and Learning (PDP)**

Strategy of Teaching and Learning (PdP) is essential to make the teaching process more meaningful and organized. The strategy of PdP not only can be seen from the wisdom of planning, method setting, technique in PdPc but also include the selection of approaches or techniques according to the learning objective, the usage of teaching materials as needed, the suitability of each methods, teaching technique, approaches and the appropriate strategies (Muhammad, 2016).

There were five strategies of teaching and learning language that were emphasized in Curriculum and Assessment Standards Documen Malay (2016), which the strategy based on 5P principle, student-centered approach, a thematic approach, various methods and techniques as well as the diversity of source materials. Figure 1 below shows the 5P principles strategies which included the strategy of integration, implementation, evaluation, recovery and enrichment.

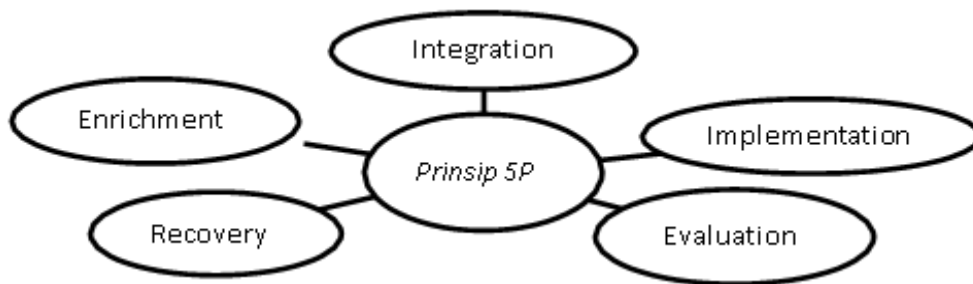
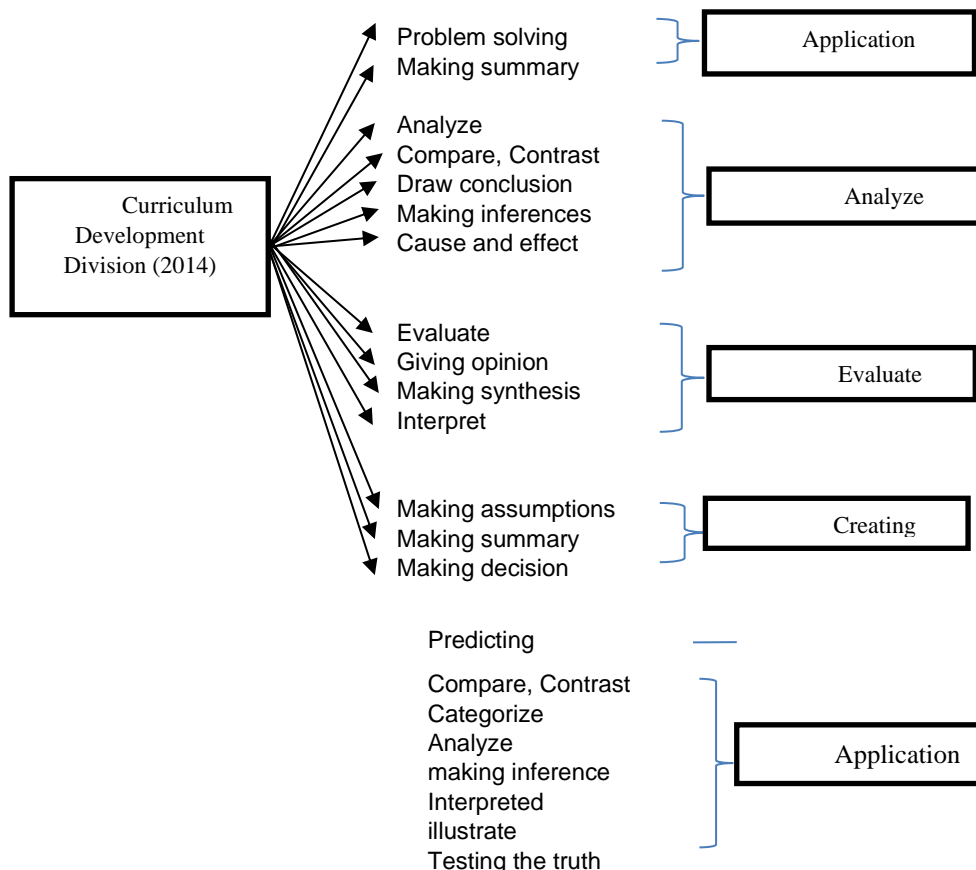

Figure 1: 5P Principles Strategies (Source: Curriculum & Assessment Standards Documen Malay, 2016) Pages: 15-22

5P principle implementation strategies were chosen because based on Curriculum and Assessment Standards Documen Malay (2016), thinking skills was one of the added value that absorbed in teaching and learning of Malay language which allows student to strengthen the integrated skills through language learning experience. Therefore, the implementation of suitable strategies were used in this study to see the HOT implementation strategies in teaching listening and speaking skills.

**Higher Order Thinking Skill Implementation Strategies**

In the context of this study, the dissemination of thinking skills embedded in these four levels of HOT were created based on the classifications that was stated by few scholars. Among them were Curriculum Development Division (2014), Yussof (2013), Basar & Yassin (2012), Mansor (2010) & Jusoh (2009). Examples as follows:



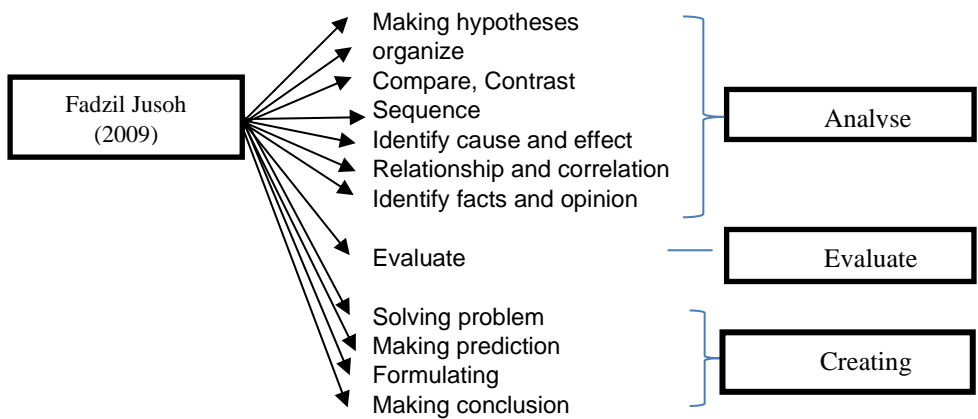
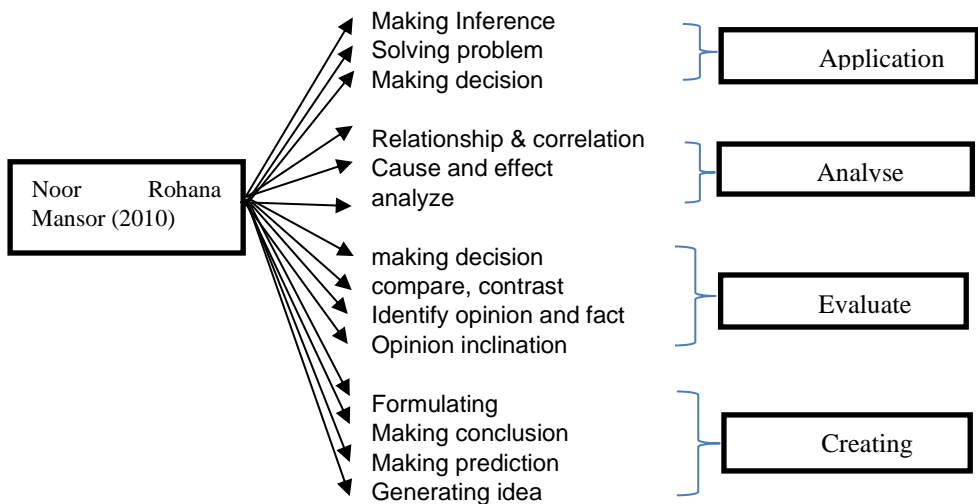
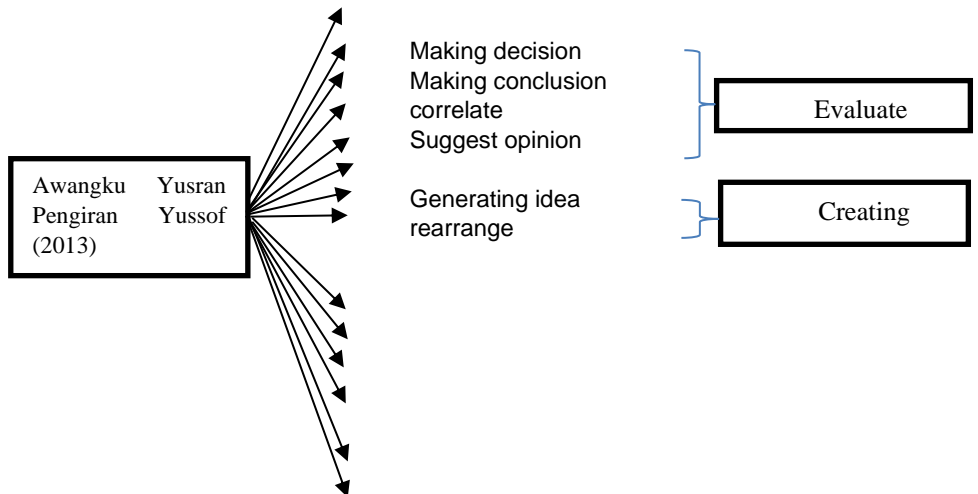

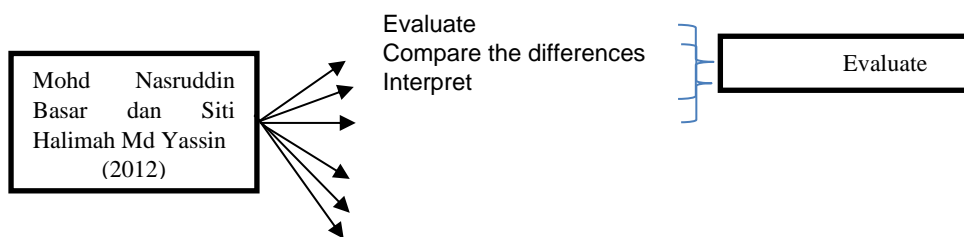

Table 1 shows the lists of thinking skills that had been observed based on the views of some scholars and are:

Table 1: Observed Thinking Skills in Teaching Malay Language

<i>Level of Thought HOT</i>	<i>Observed skills</i>	<i>Applied skills</i>
Create	<ul style="list-style-type: none"> <li>• Making conclusion</li> <li>• formulating, summarizing</li> <li>• Predicting</li> <li>• Generating idea</li> <li>• Interpretation</li> <li>• Making decision</li> <li>• Reorganize</li> </ul>	<ul style="list-style-type: none"> <li>• Making decision</li> <li>• Formulating, summarizing</li> <li>• Predicting</li> <li>• Generating Idea</li> </ul>
Evaluate	<ul style="list-style-type: none"> <li>• Synthesis</li> <li>• Evaluate</li> <li>• Identify facts and opinions</li> <li>• Detects the inclination of opinions</li> <li>• Making decision</li> <li>• Correlating</li> <li>• Interpreting, decipher</li> </ul>	<ul style="list-style-type: none"> <li>• Differentiate facts by opinions</li> <li>• Synthesis</li> <li>• Identify main idea and supporting idea</li> <li>• Evaluate</li> <li>• Identify facts and opinions</li> <li>• Detects the inclination of opinions</li> <li>• Generalization</li> <li>• Making decision</li> <li>• Correlation</li> <li>• Interpreting, decipher</li> <li>• Create sequence</li> </ul>
Analyze	<ul style="list-style-type: none"> <li>• Making mental illustration</li> <li>• Classify, grouping, categorizing</li> <li>• Making hypotheses</li> <li>• Compare and contrast</li> <li>• Organize</li> <li>• Analyze</li> <li>• Identify cause and effect</li> <li>• Making inference</li> <li>• Creating relationship and correlation</li> <li>• Making conclusion</li> <li>• Interpreting</li> <li>• Making sequence</li> <li>• Giving opinions and facts</li> <li>• Testing the truth</li> </ul>	<ul style="list-style-type: none"> <li>• Characterizing</li> <li>• Classify, grouping, categorizing</li> <li>• Making hypotheses</li> <li>• Compare and contrast</li> <li>• Organize</li> <li>• Analyze</li> <li>• Identify cause and effect</li> <li>• Making inference</li> <li>• Creating relationship and correlation</li> <li>• Identify true or false statements</li> </ul>

Application	<ul style="list-style-type: none"> <li>• Solving problem</li> <li>• Summarizing</li> <li>• Making inference</li> <li>• Making decision</li> </ul>	<ul style="list-style-type: none"> <li>• Solving problem</li> <li>• Making analogy</li> <li>• Making mental illustration</li> </ul>
-------------	---	---

Table 1 above showed the views of some scholars in the division of thinking skills that was observed at the level of applying, analyzing, evaluating and creating thought. based on the following views, researchers had included thinking skills that were applied according to the level of thought application, analyze, evaluate and create based on the frequency of scholars' views. Thinking skills that were applied at the level of thought application consist of problem-solving skills, making analogy and creating mental illustration. Whereas, thinking skills that were applied at the level of analyzing thought consist of characterizing, classifying, grouping, categorizing, making hypotheses, comparing and contrasting, organizing, analyzing, identifying cause and effect, inferring, relating and correlating and identifying true or false statements. Thinking skills applied at the level of evaluating thought included distinguishing facts with opinions, synthesizing, identifying main ideas with supporting ideas, evaluating, identifying facts and opinions, detecting idea inclination, generalizing, making decision, correlating, interpreting, deciphering and making sequences. Next, thinking skills that were applied at the level of creative thought consist of concluding, formulating, summarizing, predicting and generating ideas.

#### **The Implementation og Higher Order Thinking in Teaching Listening and Speaking Skills**

According to Curriculum and Assessment Standards Documen Malay (2016) & Yusof (2014), at the level of primary school, learning Malay language was more focused on the literacy and language applications while, at the stage II, primary school students should emphasize on strengthening and applying the four language skills.

The study on HOT in language skills in general, had been widely executed. However, in the context of past studies differed from this study as the researchers will explore the HOT implementation at the level of apply, analyse, evaluate and create thought in PdPc skills of listening and speaking. Previous studies had described in general about the implementation of HOT in all four language skills. For example, the study of Isnon & Badusah (2017) was related to the HOT implementation in general in all four language skills.

The proficiency of HOT needed long duration of time to be mastered compared to the mastery of skills or knowledge in a subject which can be mastered through the experience of appropriate HOT implementation strategies in PdPc (Zakaria & Badusah, 2014). Thus, the implementation of HOT was trained early on, which from lower education in order to easily facilitate the acceptance process at the higher level as well as could minimize the students' confusion toward the implementation of HOT in PdPc (Arshad, 2016). HOT implementation strategies could smoothly work if teachers have broad knowledge about HOT and understand the way of implementing HOT in the subjects being taught (Muhammad & Ali, 2016). Therefore, this study focused on the implementation strategies of HOT specifically in teaching listening and speaking skills.



### Anderson and Krathwohl's Edition of Taxonomic Theory (2001)

Bloom's Taxonomy has been diverse since it was introduced in 1956. Bloom's Taxonomy that often used was updated by the former student of Bloom, Loren Anderson in 2001. The significant differences between these two taxonomies was the usage of verbs for the new taxonomy to show a more active thought process.

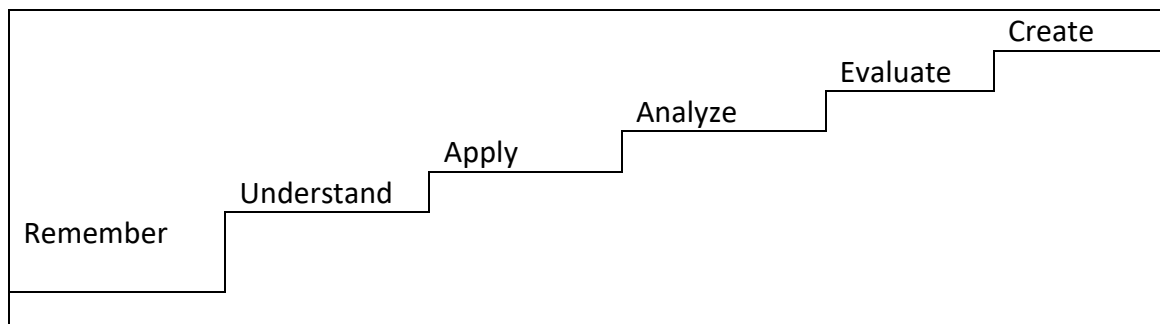

(Source: Sharuji & Nordin, 2017)

Diagram 2: Bloom's Taxonomy (2001)

Based on the new Bloom's taxonomy in figure 2, the lower stage of the taxonomy provides a foundation for learning thinking skills at the higher level. The stage of remember, understand and apply forms the relationship for the higher order thinking skills at the upper level. Anderson and Krathwohl's Theory of Cognitive Review was introduced in 2001 and was a modified theory from the original Bloom's Taxonomy Theory (1956) which in line with 21st century education needs. According to Anderson and Krathwohl's review, they divided the six cognitive levels into two levels, that was lower level which known as the Lower Order Thinking (LOT) where it consist of three stages of lower level thinking and the higher level which known as Higher Order Thinking (HOT) consist of three stages of upward thinking.

Anderson and Krathwohl Bloom's Taxonomy Theory Revised (2001) was used as the references for human level of thinking which consist of six level, which the level of understanding, remembering, applying, analyzing, evaluating and creating. According to this theory, in Malaysia LOT had encompassed the thought level of understanding and remembering while, HOT consist of the level of thought of applying, analyzing, evaluating and creating (Curriculum Development Division, 2014). Therefore, this study looked at HOT implementation strategies among Malay language teachers at four level of thought in listening and speaking skills.

### Robert Glaser's Teaching Model (1962)

The teaching model of Glaser (1962) was a model that provided guidelines for teachers to formulate appropriate teaching structures within a PdPc (Das, 2007; Sulaiman, 2012). Using this model, helped teachers to easily plan teaching process and provide teaching materials which implemented thinking skills. With this teaching model, teachers' teaching strategies will be more effective and organized.

This teaching model was divided into four sections, which were specific objectives of teaching, students' existing knowledge, teaching methods and the assessment of student performance. This model emphasized student's response to a PdPc process. According to Robert Glaser the process of teaching must begin by defining appropriate teaching objectives. The teaching



objective must described what the teacher wanted to achieve after the teaching process has occurred and usually refers to the changed in student response, acquisition and mastery of students' knowledge and skills. The teaching objectives of the teacher should be in line with the students' existing knowledge.

Existing knowledge refers to students' intellectual abilities, student motivation, social and cultural levels. Based on students' existing knowledge, teachers will formulate appropriate teaching objectives and implement their teaching plans. The final component emphasized in this model was assessment, which referred to assessing the achievement of the teaching process that has been carried out including assessment toward teaching objectives, students' existing knowledge and the implemented teaching methods. Assessment can be done by conducting question-and-answer activities, observation towards learning outcomes, execution of formal and informal test exams. The used of various teaching models by teachers could enhance the effectiveness of the PdPc process in the future and implementing teaching process more effective (Joyce, 2011; Sulaiman, 2012).

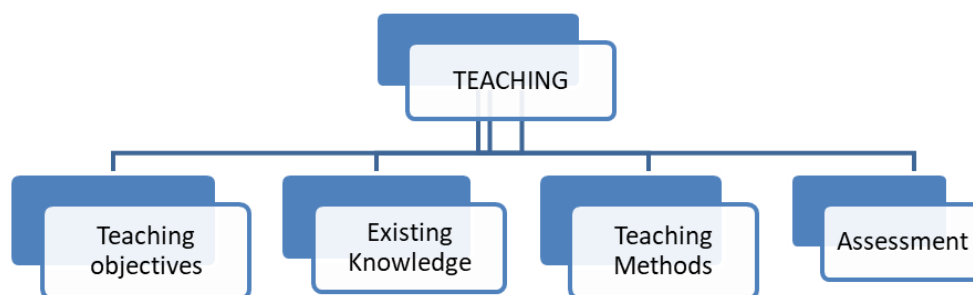

Figure 2: Robert Glaser's Teaching Model (1962)  
(Source: Sulaiman, 2012)

Based on Robert Glaser's Teaching Model (1962) in figure 3, higher level thinking skills was applied started by setting up teaching objective with HOT oriented based on the existing knowledge of the students. Teachers could find out the students' level of knowledge by asking questions based on KBAT elements which contained in the Malay language syllabus. Teacher would adapt with the suitable teaching methods according to the students' knowledge in HOT and formulate assessment through observation, questionnaire, formal or informal test to evaluate the effectiveness of the HOT implementation strategies in teaching and learning process which applied based on teaching method used. In this study, the objective of teachers' teaching, students' existing knowledge, applied teaching methods and assessment must be done based on the level of apply, analyze, evaluate and create thought.

## Research Methodology

### Research Design

Research design that was chosen and used in this study was descriptive survey method. Descriptive survey was simple and popular method which often used in the study of something that happened. Case study was used in this study in order to help the researchers understand a phenomenon in detailed and in depth as well as to enhance the existing knowledge by looking at the relationship between various objects, elements and behind

issues related to detailed phenomenon (Ishak, et al., 2013). Therefore, the used of case study allowed researchers to unearth, dismantle and explore the strategies of HOT implementation conducted by Malay language teachers in PdPc listening and speaking skills in depth and detailed through direct observation in the classroom (Idris, 2013; Jaman, 2015).

As for the strategies of HOT implementation in Malay language teachers' teaching in listening and speaking skills at Integrated Primary Religious School in Selangor, researchers had conducted direct observation in order to see the HOT implementation strategies that was applied by Malay language teachers, the used of HOT teaching methods, auxiliaries materials used by teachers throughout the PdPc and related student tasks. Through the observation, researchers obtained the data clearly and in detailed on the strategies of the Implementation of HOT which conducted by teacher in PdPc listening and speaking skills.

### Population and Research Sample

This study involved six research participants. The participants were named as research participant 1 (PK1), research participant 2 (PK2), research participant 3 (PK3), research participant 4 (PK4), research participant 5 (PK5) and research participant 6 (PK6) to maintain the confidentiality of the identity of the research participants. The research sample consist of Malay language teachers who teach Standard 5 Malay Language at Integrated Primary Religious School in Selangor. Malay Language teachers that teach Standard 5 students was selected due to upper primary students were said to have a strong mastery and able to apply language skills in Malay language PdPc Melayu (Curriculum and Assessment Standards Documen Malay, 2016). Therefore, this study focused on teachers who teach Standard 5 in order to avoid from disrupting Standard 6 learning sessions. The real background of the research participants was obtained through demographic form distributed and semi-structured interview that was conducted. All the six research participants profiles as follow:

Table 3: Research Participants Profiles

Research Participants	Age (Year)	Field of Study	The Experience of Teaching Malay Language Subject	The Experience of Teaching Standard 5 Malay Language Subject
PK1	47	Education Management	8 Years	5 Years
PK2	42	Education Management	6 Years	2 Years
PK3	50	Arabic Language	20 Years	1 Years
PK4	40	Malay Language	10 Years	2 Years
PK5	36	Islamic Education	7 Years	4 Years
PK6	43	Islamic Education	20 Years	14 Years

The interviews found that most of the teachers who teach Malay Language in SRAI were not Malay language option teachers and have the minimum qualification of Malay language at the level of Malaysian Education Certificate (SPM).

This study used purposive sampling, which based on the researchers' consideration from the aspects of knowledge and research aim selecting sample for the study conducted (Idris, 2013). The sample selected in the group must be the in same field as required in the study, could

provide data clearly, could represent and provide an accurate picture of the implementation strategies of HOT in teaching Malay language. Most of the teachers who taught Malay language in SRAI were not option teachers and the level of achievement of the Malay language of research participants were viewed as the most minimum in the Malaysian Education Certificate. In the qualitative study, the thing that was evaluated was the understanding on issues studied and the quality of study sample used was not evaluated based on the sample quantity used in conducting this study (Liamputtung, 2014).

This study selected primary school as the research area because according to Seman, et al. (2017), the implementation of higher order thinking skills should to be applied during primary schooling based on current development and needs. In addition, HOT implementation in primary school level was at the best time as the foundation to the implementation of HOT at the higher level of education.

### **Research Instrument**

This study used a main data collection method, which was direct observation method and the two methods of supportive data collection, were semi-structured and document analysis. Thus, in this study researcher used observational checklist form instrument, semi-structured questions and the materials in PdPc of listening and speaking skills as follows:

1. Part A: Direct observation (HOT implementation strategy). Part A was a part to gain information on the strategy of HOT implementation that was conducted by Malay language teachers of Integrated Primary Religious School in Selangor which involved the observation towards the implementation of 28 HOT elements, teaching method and HOT teaching assessment that were conducted by the six research participants.
2. Part B: In part B, semi-structured interview question was used to obtain each research participants' background information and students existing knowledge of HOT in every PdPc of listening and speaking sessions conducted. The interviews findings could help the researchers strengthen the direct observation research data that was conducted in this study.
3. Part C: This part referred to the distribution material used, students work and teachers' daily lesson plans (RPH) to every PdPc HOT sessions conducted by the six participants in teaching listening and speaking skills. Based on these documents, the researchers could strengthen the research findings obtained through direct observation on those six research participants.

### **Data Analysis**

In the context of this study, research data from direct observations, semi-structured interviews and related documents were analyzed according to the 28 HOT elements which were divided into four levels of HOT thinking, namely applying, analyzing, evaluating and creating. Observational data analysis was performed based on video recordings obtained through classroom observations on the study sample. Interview data analysis was carried out according to the level of students' knowledge and the suitability of the participants' teaching method which conducted through transcribed audio and for document analysis it was based on teacher's daily teaching plan (RPH), printed teaching materials and student work according

to the themes that have been set up based on Anderson and Krathwohl Taxonomy Theory Revised (2001). Through the method of observation, interview and document analysis conducted, four key elements of the PdPc process were identified, namely the teaching objectives, students' existing knowledge, teaching methods and assessment conducted by the six respondents of the study. Therefore, the Malay language teachers' HOT implementation strategies in PdPc listening and speaking skills of Malay language teachers at SRAI Selangor could be seen by analyzing every information obtained in accordance with the framework outlined in Robert Glaser Teaching Model (1962).

## Research Finding

### Participants' Classrooms Background

Research participants were six Malay language teachers who teach at SRAI Selangor. The teachers teach Standard 5 from various class. The data collected involves various classes in order to assist in the collection of different information related to the research questions as shown in table 3 below:

Table 3: Observed Class Information

Research Participants	Standard 5 Observed Class
PK 1	Excellent, Moderate
PK 2	Poor
PK 3	Excellent
PK 4	Moderate
PK 5	Excellent, Poor
PK 6	Moderate

### Discussion of Theory and Teaching Model

The research data analysis on the "Higher Order Thinking (HOT) Implementation Strategies in Teaching Listening and Speaking Skills of Malay Language Teachers at Integrated Primary Religious School in Selangor" used a theory and teaching model, which was Anderson and Krathwohl Taxonomy Theory Revised (2001) and Robert Glaser Teaching Model (1962). Anderson dan Krathwohl Taxonomy Theory Revised (2001) was used to see the HOT's implementation occurred at the level of applying, analyzing, evaluating and creating thoughts in PdPc listening and speaking skills. According to Anderson and Krathwohl Taxonomy Theory Revised (2001), the HOT implementation strategies by the six Malay language teachers at SRAI Selangor seen at the 28 HOT elements which divided into four level of higher thinking in teaching listening and speaking skills inside the classroom.

Meanwhile, Robert Glaser Teaching Model (1962) was used to measure the SRAI Malay language teachers of implementation strategies of HOT in PdPc listening and speaking skills. This model had stated that, the teaching strategy of HOT by SRAI Malay language teachers was viewed through the teachers teaching objective of HOT, students existing knowledge on HOT, teaching and HOT evaluation methods applied by the six participants in PdPc listening and speaking skills. Clearly, Anderson and Krathwohl Taxonomy Theory Revised (2001) and Robert Glaser Teaching Model (1962) were applied in analyzing research data obtained.

### HOT Implementation Strategy in Teaching Listening and Speaking Skills at the Level of Apply Thought

Generally, Malay language subject's teachers were expected to execute the HOT implementation strategies at the apply thought level, which problem-solving skills, making mental illustration and analogy making. However, research found that Malay language teachers at Integrated Primary Religious School in Selangor only executed the implementation strategies of problem-solving skills and making mental illustration.

The study also found that, Malay language teachers at SRAI Selangor have applied problem solving skills which solving the problem using the right language in a dialog. Nevertheless, research found that only a participant applied these skills in the PdPc listening and speaking skills.

Other than that, the implementation of mental illustration skills by Malay language teachers at SRAI Selangor were creating mental illustration about the danger while playing Handball, the emotion during the unhealthy condition, the condition of a house after flood disaster, not wearing shoes when playing in the field, safety features in home areas, the adjectives of the human senses and personal hygiene activities before go to school. The results of the study revealed that six participants in the study implemented the strategy of applying mental illustration skills in PdPc listening and speaking skills. Table 4 below was the HOT implementation strategies in PdPc listening and speaking skills of Malay language teachers at SRAI in Selangor.

Table 4: Higher Order Thinking Implementation Strategies in PdPc Listening and Speaking Skills of Malay Language Teachers at The Level of Apply at SRAI Selangor.

Level of HOT Thought	Higher Order Thinking Skills	HOT Implementation Categories
Apply	Problem Solving	Specifies the correct language usage in the dialog.
	Creating Mental Illustrations	Illustrate any things that can bring dangerous when playing Handball
		Make emotional representations when things are not healthy
		Illustrate the condition of the house after the flood disaster
		Illustrate playing football in the field while not wearing shoes
		Create a mental picture of security features in a home area
		Create a mental picture of the adjective of the human senses
		Create a mental illustration of your personal hygiene activities before going to school

In conclusion, only the implementation strategies of problem-solving skills and creating mental illustration occurred in PdPc listening and speaking skills. According to Robert and Glaser's Teaching Model (1962) it was found that PK1 and PK6 did not express the objectivity of HOT teaching in applying mental illustration skills while the students' existing knowledge

of HOT, HOT teaching methods and the evaluation of HOT teaching for the six study participants went well and smoothly.

### **HOT Implementation Strategy in Teaching Listening and Speaking Skills at the Level of Analyze Thought**

Theoretically, Malay language subject's teachers were expected to conduct the implementation strategies of HOT at the level of analyze thought level, which characterization skills, classifying, grouping, categorizing, hypothesizing, comparing contrasting, organizing, analyzing, identifying cause and effect, inferencing, making correlation and relationship and identifying true and false statement.

However, the study found that, Malay language teachers at SRAI Selangor only applied the skills of classifying, grouping, categorizing, comparing contrasting, analyzing, identifying cause and effect and making correlation and relationship. Nevertheless, the findings of the study found that only one participant applied the skills of making correlation and relationship, three participants applied the skills of classifying, grouping and categorizing, four study participants applied the skills of identifying cause and effect, all six participants applied analytical skills, one participant of the study applied the skills to identify true or false statements and two study participants applied skills to compare contrast in PdPc listening and speaking skills.

The skills implementation in making correlation and relationship conducted by Malay language teachers at SRAI Selangor was making correlation between the one's health and emotion. Whereas, the application of the skills of classifying, grouping and categorizing was carried out by classifying images as human emotions. The implementation of identifying cause and effect skills conducted was identifying the cause and effect of sadness, happiness, anxiety, anger, stress, if not following the safety guidelines on the road and if not following the guidelines while purchasing food ingredients. The implementation of analytical skills was analyzing the suitable songs with the emotion of happiness and sadness, how to get a healthy body and a smart brain, example adhesive adjective, examples of foods rich in vitamins, calcium, iron and protein, hiking and swimming safety equipment, categories of compound word with examples, the cause of road accident and the correct use of collective nouns. Next, the application of compare contrast skills conducted by the participants was compare contrast the criteria between Football and Futsal, differentiation of interrogative noun sentences using -kah particle with without -kah particle and the interjection for "amboi" and "nah" which have two different meanings. The implementation of identifying true or false statement skills was identifying the true or false adjective nouns based on the Nine categories. Table 5 below was the implementation strategies of HOT at the level of analyzing thought in SRAI Selangor Malay language teachers' PdPc listening and speaking skills.

Table 5: Higher Order Thinking Implementation Strategies in PdPc Listening of Malay Language Teachers Analyzing Level at SRAI Selangor

Level of HOT Thought	Higher Order Thinking Skills	Higher Order Thinking Implementation Categories	
Analyzing	Compare and Contrast	Comparing contrasting the criteria between Football and Futsal	
		Comparing contrasting interrogative nouns using -kah particle with without -kah particle	
		Comparing contrasting the meaning of the interjections of “Amboi” and “Nah” which have two different meanings	
	Making Correlation and Relationship Skills	Making correlation and relationship between one’s health and emotion	
	Classifying, grouping, Categorizing Skills	Classifying images as human emotions	
	Identifying Cause and Effect Skills		Identifying cause and effect of sadness, happiness, anxiety, anger and stress among students
			Identifying the cause and effect of not following the guidelines during flood
			Identifying cause and effect of not following the safety guidelines when on the road
			Identifying cause and effect of not following the guidelines while purchasing food ingredients
	Analyzing		Analyze suitable songs with the emotion of happiness and sadness
			Analyze the group of sports activities together in the graph
			Analyze how to get a fit body and a smart brain
			Analyze examples of adhesive adjectives aside textbooks
			Analyze examples of foods rich in vitamins, calcium, iron and protein
			Analyze safety equipment for mountain climbing and swimming
			Analyze categories of compound words with the right examples
Analyze predefined compound words examples			
Analyze the various compound words contained in the text			
Analyze the causes of road accidents			
Analyze the use of collective nouns correctly.			
Analyzing True of False Statement		True or false adjective nouns according to Nine categories	

It can be concluded that only the implementation strategies of the skills of compare contrast, making correlation and relationship, classifying, grouping, categorizing, identifying cause and effect, analyzing and identifying true or false statement that occurred in PdPc listening and speaking skills at the level of analyzing. According to Robert and Glaser's (1962) Teaching Model, PK1 did not express the objectives of HOT teaching in applying skills to compare



contrast and identify the cause effect while the students' existing knowledge of HOT, HOT teaching methods and evaluations of HOT teaching for all six participants were conducted well and smooth.

### **HOT Implementation Strategy in Teaching Listening and Speaking Skills at the Level of Evaluation Thought**

Malay language teachers were expected to run the HOT implementation strategies at the level of evaluation thought, which were differentiating fact and opinion skills, synthesizing, identifying the main and supporting idea, evaluating, identifying fact and opinion, detecting opinion inclination, generalizing, decision making, correlating, interpreting, deciphering and organizing.

Nevertheless, the findings found that, Malay language teachers at SRAI Selangor only implemented the skills of interpreting, deciphering, evaluating, correlating, identifying fact and opinion, identifying opinion inclination and decision making. However, research has found only two participants implemented the skills of interpreting, deciphering, another two participants implemented correlating skills, one of them has applied identifying fact and opinion skills, two participants applied the skills of identifying opinion inclination, and one participants implemented decision making skills in PdPc listening and speaking skills.

The implementation of interpreting, deciphering executed by Malay language teachers at SRAI Selangor was deciphering graphic material before building full reviews and interpret distributed graphical material. Meanwhile, the application of evaluation skills conducted was evaluating the appropriate language in a dialog and evaluate the type of shoes and trousers for hiking. The implementation of correlating skills was the correlation of drinking enough water with good digestive system and road accidents with the factors of accidents. Furthermore, the application of skills in identifying facts and opinions was identifying opinions on activities for those who are overweight. The implementation of identifying the inclination of opinion was the opinion inclination of the idea of the use of shoes to play in the field and the inclination of the adjective of time. Next, the implementation of decision-making skills was making decision in the use of shoes when playing in the field. Table 6 was the HOT implementation strategies at the level of evaluation thought in PdPc listening and speaking skills of Malay language teachers of SRAI in Selangor.

Table 6: The Implementation Strategies of Higher Order Thinking Skills in PdPc Listening and Speaking Skills of Malay Language Teachers in SRAI Selangor

Level of HOT Thought	Higher Order Thinking Skills	HOT Implementation Categories
Evaluate	Interpretation, Decipher Skills	Interpret distributed graphical materials by research participants
		Interpret graphical materials before building full reviews
	Identify Opinion Inclination Skills	Inclination of opinions on the adjective of time
		The inclination of opinions on the usage of shoes during playing in the field
	Decision Making Skills	Making decision in the use of shoes when playing in the field
	Correlating Skill	Correlate between drinking enough water with good digestive system
		Correlate road accidents cases with the causes of the accidents
	Identify Fact and Opinion Skills	Identifying the opinions on the suitable activities for those who are overweight
	Evaluation Skills	Evaluate the appropriate language in a dialog
		Evaluate the types of shoes and trousers for mountain climbing

It can be concluded that only the implementation strategies skills of interpretation, deciphering, identifying opinion inclination, making decision, correlation, identifying fact and opinion and evaluation. In accordance with Robert and Glaser's Teaching Model (1962), all study participants stated the HOT teaching objectives, students existing knowledge of HOT, HOT teaching methods and the evaluation of HOT teaching for all six study participants performed well and smoothly.

### **HOT Implementation Strategy in Teaching Listening and Speaking Skills at the Level of Create Thought**

Generally, Malay language teachers expected to conduct implementation strategies of HOT at the level of create thought, which was the skills to conclude, summarize, formulate, predict and generate ideas.

However, the findings showed that Malay language teachers in SRAI Selangor only implemented the skills of generating ideas and did not implement the skills to conclude, formulate, summarize and predict at the level of create thought in PdPc listening and speaking skills. Nevertheless, research has found that only three participants applied generating ideas skills in PdPc listening and speaking skills.

The implementation of generating ideas skills conducted by Malay language teachers in SRAI Selangor was generate the ideas with explaining the sentence statement, interjection sentence, question sentence with example, construct sentence using prefixes of adjective,

building sentence based on the predefined interrogative noun and creating sentence based on the predefined collective noun. Table 7 below was HOT implementation strategies at the level of create thought in PdPc listening and speaking of Malay language teachers at SRAI in Selangor.

Table 7: The Implementation Strategies of Higher Order Thinking Skills in PdPc Listening and Speaking Skills of Malay Language Teachers in SRAI Selangor

Level of HOT Thought	Higher Order Thinking Skills	HOT Implementation Categories
Create	Generate Idea	Generating ideas by explaining the meaning and giving example for sentence statement, interjection sentence and interrogative sentence
		Generating ideas of constructing sentences using prefixes of adjective
		Generating ideas based on predefined interrogative noun
		Generating ideas according to the predefined collective noun

It can be concluded that only implementation strategies of generating ideas skills that occurred in PdPc listening and speaking skills. Based on Robert and Glaser's Teaching Model (1962), the study participants reported the HOT teaching objectives, students' existing knowledge of HOT, HOT teaching methods and the evaluation of HOT teaching went well and smoothly.

### Conclusion

The findings of the study found that only 14 of 28 HOT implementation strategies in PdPc listening and speaking skills occurred. At the level of apply thought, the HOT implementation strategies happened in the skills of problem solving and mental illustration while analogy skills did not occur. At the level of analyze thought, the implementation strategies of HOT occurred in the classifying, grouping and categorizing, comparing contrasting, analyzing, identifying cause and effect and making correlation and relationship. Whereas, the skills to characterize, hypothesize, organize, infer and identify true and false statements did not implemented. At the level of evaluate thought, the implementation strategies of HOT occurred in evaluation skills, identifying fact and opinion skills, identifying inclination of opinion skills, correlating skills, decision making skills and interpretation, decipher skills. However, skills in distinguishing facts and opinions, synthesizing, identifying main ideas and supporting ideas, generalizing and organizing did not apply in PdP. At the level of creative thought, only the skills of generating ideas was applied and the skills of concluding, formulating, summarizing and predicting however did not happened. 14 implementation strategies of HOT in PdPc listening and speaking skills were as follow:

Table 8: Higher Order Thinking Implementation Strategies in PdPc Listening and Speaking Skills

Level of Thought	28 Implementation Strategies of HOT	Listening and Speaking Skills
Apply	Problem Solving	/
	Making Mental Illustration	/
	Create Analogy	X
Analyze	Characterize	X
	Classify, Group, Categorize	/
	Hypothesizing	X
	Compare Contrast	/
	Organize	X
	Analyze	/
	Identify Cause and Effect	/
	Inferencing	X
	Making Correlation and Relationship	/
	Identify True or False Statement	X
	Evaluate	Distinguish Fact and Opinion
Synthesize		X
Identify Main and supporting Idea		X
Evaluate		/
Identify Fact And Opinion		/
Detect Opinion Inclination		/
Generalizing		X
Making Decision		/
Correlate		/
Interpret, Decipher		/
Makin Sequence		X
Create	Create Conclusion	X
	Formulate, Summarize	X
	Predict	X
	Generate Idea	/

The analysis of the study results showed that study participants were less concerned with setting the objectives of teaching HOT in their RPH, for instance in the teaching of PK1, PK2 and PK6. The data analysis of semi-structured interviews found that all the participants have set the HOT teaching objectives based on students' existing knowledge, which the general knowledge, when they were in lower primary, since standard 4 and only learned in standard 5. According to the observation made, it found that research participants used HOT teaching method such as brainstorming method, discussion, explanation and presentation. Meanwhile, HOT assessments were based on student question and answer activities and informal tests.

Based on the findings obtained the Malay language teacher at Integrated Primary Religious School in Selangor adopted various HOT strategies in listening and speaking skills at applying,

analyzing, evaluating and creating level. From 28 implementation strategies of HOT, the results showed 14 implementation strategies at various levels of thought has been run by the Malay Language teachers at Integrated Primary Religious School in Selangor. Through the results of this study allow Malay Language teachers or teachers of other subjects to know how to exercise some implementation strategies of HOT in detail. However, to achieve the goal of PPPM (2013-2025) to improve the level of education in the country on par with other countries, researchers feel the need to conduct further studies to know in more detail 28 strategies of application of HOTS at all four levels of thinking. Based on this study, the researcher suggested the future researchers is expected to explore on the implementation strategies of HOT in teaching reading and writing skills in order to know how to implement of 28 application HOT strategies as a whole, the similarities and differences application strategies of HOT carried out in the three PdPc language skills.

### References

- Arshad, A. Y. (2016). *Penambahbaikan Kemahiran Berfikir Aras Tinggi Melalui Pembelajaran Berasaskan Masalah Bagi Subjek Sains Tingkatan 2*. Bangi: Universiti Kebangsaan Malaysia.
- Basar, M. N., & Yassin, S. H. (2012). *Kemahiran Berfikir*. (Ikhwan Ahmad Naim, Ed. Pertama). Balakong: Freemind Horizons Sdn. Bhd.
- Curriculum and Assessment Standards Documen Malay*. (2016). Putrajaya: Kementerian Pendidikan Malaysia, 1–50.
- Curriculum Development Division. (2014). *Kemahiran Berfikir Aras Tinggi: Aplikasi di Sekolah*. Kementerian Pendidikan Malaysia. Retrieved from <https://doi.org/10.1017/CBO9781107415324.004>
- Das, R. C. (2007). *Science Teaching In Schools*. New Delhi. Sterling Pubisher.
- Idris, N. (2013). *Penyelidikan dalam Pendidikan*, Edisi Kedua. Kuala Lumpur: Mc Graw Hill.
- Ishak, N., Yassin, S. F., Hamzah, M. I., & Ariffin, S. R. (2013). Kaedah Kajian Kualitatif. Dalam *Penyelidikan dalam Penyelidikan*, 345–370. Kuala Lumpur: Mc Graw Hill.
- Ismail, N. (2014). Peranan Guru dalam Merealisisi Pelan Pembangunan Pendidikan. *Pelita Bahasa*, Bil 2, 12-14.
- Ismail, N., & Mahamod, Z. (2016). Sikap dan Kediaan Pelajar Sekolah Menengah Terhadap Kemahiran Berfikir Aras Tinggi dalam Pembelajaran KOMSAS Bahasa Melayu. *Jurnal Pendidikan Bahasa Melayu*, 6(2), 59–67.
- Isnon, H., & Badusah, J. (2013). Pencapaian Bahasa Melayu yang rendah dalam kalangan calon Penilaian Menengah Rendah. *Jurnal Pendidikan Bahasa Melayu*, 7(1), 56–65. Retrieved from <https://doi.org/10.1017/CBO9781107415324.004>
- Isnon, H., & Badusah, J. (2017). Kompetensi Guru Bahasa Melayu dalam Menerapkan Kemahiran Berfikir Aras Tinggi dalam Pengajaran dan Pembelajaran (Malay Language Teacher Competency to Implementation Higher Order Thinking Skill in Teaching and Learning). *Malay Language Education Journal – MyLEJ*, 7(1), 2180–4842. Retrieved from <http://journalarticle.ukm.my/10413/1/133-256-1-SM.pdf>
- Jaman, J. (2015). *Pelaksanaan Program Pemulihan Bahasa Melayu Sekolah Rendah dan Keberkesanan dalam Mengatasi Masalah Buta Huruf*. (Unpublished master's thesis). Universiti Putra Malaysia.
- Joyce, B., Weil, M., & Calhoun, E. (2011). *Model Of Teaching* (8<sup>th</sup> ed.). Boston: Allyn & Bacon.
- Jusoh, F. (2009). *Peranan Minda dalam Kemahiran Berfikir*. (T. Sulaiman & A. Hassan, Eds. Pertama). Serdang: Penerbit Universiti Putra Malaysia.

- Liamputtong, P. (2014). *Kaedah Penyelidikan Kualitatif*. (Haliza Mohd Riji & Shamsuddin Ahmad, Eds. Ketiga). Serdang: Penerbit Universiti Putra Malaysia.
- Mansor, N. R. (2010). *Aras Kognitif Soalan*. Kuala Terengganu: Penerbit Universiti Malaysia Terengganu.
- Ministry of Education. (2013). Kurikulum Standard Sekolah Rendah, 1–56. Retrieved from [www.moe.gov.my](http://www.moe.gov.my)
- Ministry of Education. (2014). Elemen KBAT dalam Pedagogi. Bahagian Pembangunan Kurikulum. Retrieved from <https://doi.org/10.1007/s13398-014-0173-7.2>
- Muhammad, N. A. (2016). *Pengetahuan Guru Pendidikan Islam Mengenai Kemahiran Berfikir Aras Tinggi (KBAT) dan Strategi Penerapannya dalam Pengajaran*. (Unpublished master's thesis). Universiti Kebangsaan Malaysia.
- Muhammad, S., Ali, R., S. N. I. (2016). Tahap Amalan Penerapan Kemahiran Pemikiran Kritis (KPK) di Sekolah Menengah Berprestasi Tinggi, Sederhana dan Rendah. *International Seminar on Generating Knowledge Through Research*, UUM-UMSIDA, 1 (October), 1–9. Retrieved from <https://doi.org/10.21070/picecrs.v1i1.639>
- Seman, S., Yusoff, Y. S., & Embong, R. (2017). Teachers Challenges in Teaching and Learning for Higher Order Thinking Skills (HOTS) in Primary School. *International Journal of Asian Social Science*, 7(7), 534–545. Retrieved from <https://doi.org/10.18488/journal.1.2017.77.534.545>
- Sharuji, W. N. S., & Nordin, K. (2017). Kesiapan Guru Dalam Pelaksanaan Kemahiran Berfikir Aras Tinggi (KBAT). *Simposium Pendidikan*, 1(2017), 140–146.
- Sulaiman, S. (2012). Tahap Penguasaan Proses Sains dan Sikap Guru Serta Halangan dalam Pengajaran Kemahiran Sainifik Bagi Mata Pelajaran Sains Pertanian. (Unpublished master's thesis). Universiti Putra Malaysia.
- Yusof, T. J. (2014). *Kaedah Pengajaran Bahasa Melayu Sekolah Rendah (kelima)*. Pusat Bandar Puchong: Penerbitan Multimedia Sdn. Bhd.
- Yusoff, A. Y. (2013). *Kemahiran Berfikir Menggunakan Kaedah Penyoalan dalam Pengajaran Fahaman* (Pertama). Brunei: Dewan Bahasa dan Pustaka.
- Zakaria, A. H., & Badusah, J. (2014). Penerapan Kemahiran Bernilai Tambah dalam Pembelajaran dan Pemudahcaraan Bahasa Melayu di Sekolah Rendah. Dalam Zamri Mahamod *et al.* (Pnyt.). *Prosiding Seminar Pascasiswazah Pendidikan Bahasa Melayu dan Kesusasteraan Melayu Kali Ketiga*, 81–94. Bangi: Penerbit Fakulti Pendidikan, Univsersiti Kebangsaan Malaysia.