

## M40 Muslim Households Indebtedness for Luxury from Islamic Perspective

Hainnur Aqma Rahim<sup>1</sup>, Murni Yusoff<sup>2</sup> & Zakaria Bahari<sup>1</sup>

<sup>1</sup>University Teknologi Mara, <sup>2</sup>University Sains Malaysia

Email: murniyusoff.usm@gmail.com

To Link this Article: <http://dx.doi.org/10.6007/IJARBS/v10-i10/7942>

DOI:10.6007/IJARBS/v10-i10/7942

*Published Date:* 19 October 2020

### Abstract

This research examines three variable components of M40 Muslim behavior comprise of understanding of Islamic debt principles, credit facilities offered and confidence in Islamic banking / financial products towards the purpose of indebtedness for luxury from an Islamic perspective. The M40 Muslim household's attitude towards debt is a mediator to the relationship between the independent and dependent variables. This research uses a quantitative research approach by distributing questionnaires to M40 Muslim debtors in Selangor. Data were collected using samples of 438 respondents from M40 Muslim who were indebted in Selangor based on stratified random sampling techniques and analyzed using Structural Equation Modeling (PLS-SEM). The findings of this research have shown that with the variable of understanding of Islamic debt principles, credit facilities offered are significant to the attitude of Muslim debtors, while Muslim confidence in Islamic banking / financial products is not significant to Muslim's attitude of debt. In addition, the findings also show that the attitude of Muslims to debt is significant and is capable of being a mediator between the variables of M40 Muslim households with the aim of being indebted to enjoy the luxury. In this research, the understanding of Islamic debt, the credit facilities offered and the attitude of indebtedness have a significant impact towards the motivation among the Muslim households to be indebted for luxurious means.

**Keyword(s):** Behaviour, Muslim, Debt, Attitude, Household, Luxury.

### Introduction

These days, debt transactions have become part and parcel of very household in order for it to be able to have basic necessities (Hodari, 2014). Debt is an amount of money lent by an individual, a bank or an institution to another person, characterised as a liability or a financial demand for a given period of time in future (Tahir & Yusof, 2014). It is typical for the household loans to be made to gain property, to purchase a vehicle or appliances, to make investments in equity and to cover the general expenses (Cynamon & Fazzari, 2010). An individual is also in debt when the goods or services are no longer afforded in cash and if they are needed urgently (Tahir & Yusof, 2014). This culture of indebtedness has long

been rooted since the emergence of Islam (Ismail, 1992). Debts are one of the akad muamalah in Islam which means that it is permissible in Islam. In this akad, indebtedness is also recommended if the debts are able to instil mutual help, as long as the akad performed does not violate the shara' (Alidaniah, Ahmad & Noor, 2015).

In recent times, the trend of the increasing amount of household debts in the Malaysian society is becoming more and more critical. Although positively speaking, the amount of debts leaves a positive impact to the economic growth through goods consumption and services via debts (Abidin, Sarmidi & Nor, 2013), the society's failure in managing its debts and controlling their spending habit to obtain luxurious items can lead to a severe economic crisis (Zakaria et al., 2012). For example, the trend of household debt growth noted an increase to surpass 89.1 percent for the ratio of household debt to the Gross Domestic Production (GDP) in 2015 compared to 86.8 percent in the previous year (BNM, 2015). The figure has placed Malaysia as the country with the highest level of debt in Asia.

Meanwhile, Malaysia Gazette (2017) also reported the statement issued by Datuk Seri Azalina Othman Said in the Dewan Rakyat that the highest number of cases of bankruptcy was noted in Selangor with 72,114 cases (24.30%) whereas the lowest is in Perlis with 1,037 cases (0.35%) as of August 2017. The crisis of bankruptcy following accumulated debts and a severe debt crisis has indirectly been able to leave both physical and mental impacts involving individuals, family, society, country and even globally. For instance, there is a family conflict that can adversely impact the life quality of its family members. Even more unfortunate, the children's mental development is also affected due to the financial issues faced by families burdened by serious debts.

The understanding about the seriousness of the sin for debtors who deliberately do not pay off their debts should justify why Muslims should be indebted moderately and not making debts for luxurious means, further leading to a severe debt crisis. However, the studies about debt issues come to another finding, when Malays have high level of tendency to commit to non-guaranteed debts like personal financing and credit cards, and have low awareness towards the obligatory Sharia compliant loan compared to the Chinese and Indians (Alidaniah et al., 2015).

The current scenario observes that the aim to make debt among less affordable households is to fulfill the needs, whereas the better off households are indebted for luxurious, materialistic means. (Rahim et al., 2012). The reality of living luxuriously among the Malays can be seen in the findings from Alidaniah et al. (2015) showing that the Malays are the majority who practise luxurious culture compared to the Chinese and Indians. Meanwhile, Ahmed Razman Abdul Latiff in a press statement from asserted that middle income households (M40) spend more than their total income. Looking into the scenario of the behaviour of M40 Muslims in this debt culture, what are the factors that influence their attitude in making debts? Next, how does their debt-making behaviour influence their purpose to be indebted for luxurious means?

## Literature Review

The past literature presents the four instruments that influence the indebted society namely luxury, attitude, the understanding about the debt principle in Islam and the credit facilities offered.

### 1. *Luxury*

Other than the factor of peer motivation encouraging the debt culture and that they still feel that the assets owned are insufficient, one of the factors for being indebted is due to the needs and desire to spend luxuriously or to have goods beyond one's affordability (Kamleitner & Kirchler, 2007; Akhyesr, 2012; Wang et al., 2011). Sapora et al. (2014) also explain that the household attitude, who likes to spend more than their affordability is among the causes of the trend of the household that is on the rise in Malaysia. Easy and comprehensive credit access can spur a luxurious lifestyle and culture based on the Malaysian Consumers Expenditure Growth and Development, BNM (2010).

Unfolding history, the debt culture for luxurious purposes was practised by the royal family in Kedah (Ahmat, 1984). Their sultan and families at the time were really into gambling and were willing to make debts with the moneylenders and Chinese traders just to live in luxury (SMSAH No. 6, 1897). In addition, the debt was not for necessities like building homes and palaces, purchasing decorative items gifts for the queen, which the Sultan had treasured (C.O. 273/293). Other than that, Sultan Abdul Hamid also held a royal wedding feast for five of his daughters at such a grand scale at whopping 3 million Ringgit, an event which was later called 'The Three-Million Ringgit Wedding' (Shahabudin & Knowles, 1958).

Besides Kedah, the Perak royal families also displayed debt-making tendency for luxury as they organised certain events for the purpose of increasing their social status (Badiozaman, 1975). Other than this culture permeating among the royals, the Malay community also likes to make debts to hold festive events, weddings and to solve their gambling debts (Swettenham, 1895).

### 2. *The Understanding About the Principle of Islamic Debt*

The understanding could be explained three-fold (Jusoh, 2014). The first is that the understanding is something that can be obtained through the mind. Secondly, the practice or behavior done through the mind can well produce new acquisitions through the sense or taste. Thirdly, understanding is the role of the mind in explaining something by combining the feelings through the mediating words. Meanwhile, understanding also has a close connection with one's behavior as humans are created from the soul and the body (Jusoh, 2014).

In specific, a detailed understanding about something would entail that of attitude, and furthermore the attitude will be able to influence one's practice or behavior towards doing good. This can be proven in the decree of Allah SWT: "Thus, know that there is no God but Allah and ask forgiveness for thy fault, and for the men and women who believe- and for Allah knows how you move about and how you dwell in your homes- do ask for His forgiveness for every wrong you have committed" (Muhammad, 47:19). According to IbnuKatsir (2008) about the verse, Allah SWT had ordered the Prophet Muhammad SAW to understand the *Tawheed* first whereby there is no god but Allah SWT and ordered him to practise it which is by asking for His forgiveness. Although the debt-making is allowed in Islam, Muslims should

ensure that the debt made complies with the *Shara'*. This is very important to be closely examined as if the debt fails to be managed properly, issues like dispute lies, oppression, and revenge will emerge and will later fragment the ummah themselves. Thus, Muslims should have a very good understanding about the debt practice in Islam.

The research conducted by Sobian and Rahman (2010) about the Muslims' understanding about debt in Islam has found that 54.5 percent among the respondents understood about the Islamic principles on loaning. That said, respondents' level of understanding in light of Islamic debts is still unsatisfactory, after they were required to list the needs to make debts by priority, according to Islam. Most answered that steering clear of *riba'* was the main need, when the answer should be recording details of the debt and having a witness for that matter. A similar finding was found in Jusoh (2014) about the understanding of the concept of debt in Islam based on the respondents' demography, whereby it is found that the highest level of understanding was from those who were religious-educated compared to those from the national-streamed education. The lowest level of understanding was found by Alidaniah et al. (2015) where the respondents who obtained non-sharia compliant loans are the Muslim Malay respondents. Thus, the first hypothesis is:

H1: Attitude has a significant influence on the purpose of being indebted for luxury among M40 Muslims.

### **3. Credit Facilities Offered**

Other than the factor of needs and desire to get something that cannot be owned in cash, the feeling that making debts is easy is also one of the factors that influence one to be indebted (AkYesr, 2008). The factor of credit facilities offered in the research done by Raja Mohar (1975) established that the Perak Malay community, is synonymous with the debt culture with the moneylenders at the time because it was easy to borrow money from them. The moneylenders' generosity and kindness at the time had made them feel comfortable and it was easy to loan some money although the interest rate was high (Abdullah, 1984).

Nowadays, the credit facilities offered influence the household to choose to use the debit card compared to the credit card and the charge card. This is consistent with the report issued by BNM (2014) where it is found that 82.5 percent of the household choose to use the debit cards compared to the other two, credit cards and charge cards. Thus, the second hypothesis is:

H2: Credit Facilities Offered has a significant influence on the attitude of M40 Muslims to be indebted.

### **4. Confidence on The Islamic Banking /Islamic Finance Products**

The concept of product choice depicts users' belief that Islamic housing financing is open to many product presentation choices (Chen et al., 2004). In general, Islamic banks are involved in the development of new products and sustaining their lifespan through user priorities. Following this concern, Islamic banks are expected to offer a greater product choice compared to their conventional counterparts, with more choices in terms of the Shari'a principles, different product characteristics, various brands and new product offerings. Customers tend to visit the Islamic banks that offer a great range of products. If the product choice fulfils their expectation, customers have the tendency to consider that the branch is good and will

continue to visit the branch (Ahn et al., 2004). Although the product choice is important to the Islamic financing of homes, also to the relationship between product choice and consumers' attitude, consumers' confidence on the Islamic banking/financing products that influences their attitude in being in debt has yet to be explained adequately. Most of the past studies discussed on the factor of effective demand towards Islamic broken promises among users (Dar, 2002). Besides, Tameme and Asutay (2012) found that the factors of social and lifestyle are the most important factors in the Islamic housing financing products. Chen and Tan (2004) found that product offering influences the attitude towards the use of digital shops. All literature surveys have limited themselves on looking into only consumers' attitude, but none has examined the consumers' attitude towards debts. Thus, the third hypothesis is as follows:

H3: The confidence towards the Islamic banking/financing products has a significant influence on the attitude of M40 Muslims to make debts.

### **5. Attitude**

In general, Attitude is able to influence one's behaviour to make debts (Cosma & Pattarin, 2010; Wang et al., 2011). This can be proven through the finding by Cosma dan Pattarin (2010) showing that the components of Attitude like Affective, Behaviour and Cognitive are able to exert their influence on the use of credit for the Italian community. The same finding is established by Wang et al. (2011) where it is found that the household attitude comes from Affective dimension and Behaviour influences the purpose of making debts.

The factor of Attitude on the purpose of debt-making among Muslims from the Islamic perspective have been the main concerns of researchers, Sobian and Rahman (2010). Several aspects such as the purpose of making personal loan, the choice of loaning product, the source of information on the loan scheme, the total amount of the loan, the things to consider when applying for the loan, the repayment method and the commitment of the debtors in repaying, are all factors under Attitude that are relevant for Muslims' debt-making.

Meanwhile, the attitude towards the purpose of debt-making consistently changes, showing that the attitude towards debts is dynamic (Davies & Lea, 1995). This can be proven through the finding on a group of students with different attitudes by year of research, where students who are in the middle of their studies are more easily exposed to indebtedness compared to students who have just started their research years. Thus, the fourth hypothesis is:

H4: Attitude towards debts has a significant influence towards the purpose of M40 Muslims making debts for luxury.

### The Conceptual Framework of the Research

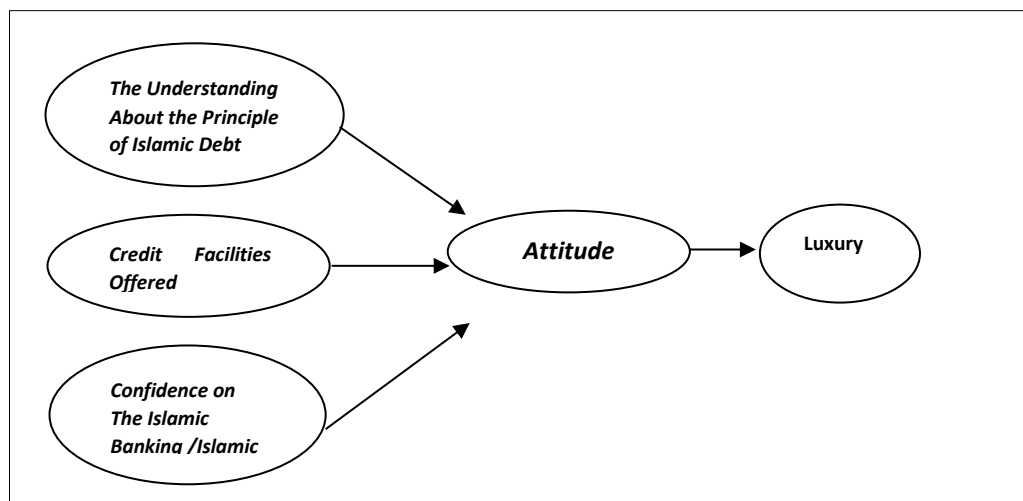

Diagram 1: The Research's Conceptual Framework

Diagram 1 shows the determiners of the M40 Muslims indebted for luxury. The determiners comprise of the construct of understanding about the Islamic debt principles, feeling that it is easy to make debts, being confident about the Islamic banking/financing products and attitude. Luxury stands to be the purpose for M40 Muslims' indebtedness.

## Research Methodology

### 1. Data Collection

His research adopts the quantitative approach with the cross-sectional design. This research instrument uses the questionnaire form to look into the determiners of the M40 Muslims' debt-making for luxurious purposes. The population comprises of Muslims who are indebted among the M40 Muslim households. Selangor is chosen as the sampling location considering the fact that the percentage of bankruptcy is the highest (Malaysia Insolvency Department, 2017). Other than that, M40 Muslims who are indebted become the research sample to take into account the middle income group that plays an important role in the national economic development (Dyck, Hansakul & Saxena, 2009) and the Malays are the race who has been noted to constitute the highest percentage of bankruptcy compared to the Chinese and Indians (Malaysian Insolvency Department, 2017).

The research population in Selangor totals 2,680,000 people and the sample size required is at least 70 people based on the table of determination of the sample size in the Structure Equation Model (PLS-SEM) to achieve the  $R^2$  value= 0.25 at the significant level of 0.05 (Hair et al., 2014;2017). The total sample of 384 is required based on the Krejcie & Morgan's Sampling Table (1970). Thus, researcher combines both these techniques to ensure the accuracy of the minimum number of samples that can be between 70 and 384 people. The combination of both is carried out to enable generalisation and to fulfil the requirement of the advanced analysis technique of Partial Least Squares-Structural Equation Modeling (PLS-SEM) (Hair et al., 2014; 2017).

The questionnaire form is the instrument of this research and it contains five sections. Section A contains general information about the demographic variable including the gender, age, status, level of education and the level of income of the respondent's household measured



based on the nominal measurement scale and ratio. Section B contains items related to debt-making for luxury adapted from Adzis et al. (2017). Items related to the understanding about the Islamic debts principles are adapted from Jusoh (2014). Items related to the confidence about Islamic banking/financing products are adapted from Amin et al., (2017). Items related to attitude are adapted from Johan Almenberg, Annamaria Lusardi, Jenny Save-Soderbergh & Roine Vestman (2016). All items are made uniform in the measurement of all variables using the interval scale comprising of 1=strongly disagree, to 5=strongly agree.

The research data is analysed using the descriptive statistics to explain the profile of the respondents aided by the software IBM SPSS 22.0, whereas inferential statistics is employed to test the hypotheses using the advanced analysis technique, Partial Least Square Structural Equation Modeling (PLS-SEM) through the software Smart-PLS 3.0. The data analysis is formed based on the reflective measurement model and the structural equation model. The analysis of the respondents' demography involves 438 respondents as shown in Table 1.

## **Research Findings**

### **1. Descriptive Research Sample**

Based on Table 1, a total of 438 respondents are involved in this research where 151 respondents (34.5%) are male and 287 (65.5%) are female. A large number of respondents are married (69.4%). The majority of them are in the range of 30-39 years old (48.2%). A lot of the respondents have Bachelor Degree (35.8%), followed by Diploma (24.4%), *Sijil Pelajaran Malaysia* (21.7%), *Sijil Tinggi Pelajaran Malaysia* (7.3%), *Penilaian Menengah Rendah* (5.9%) and PhD (3%). The majority of the respondents are government staff (Support Group) (31.5%). Most of the respondents have the salary in the range of RM 4,000 – RM 5,000 (66.2%) which is this group of people comes from M40 household. M40 household was selected as a respondent because the M40 or (middle income group in Malaysia) need to pay various taxes such as the personal income tax, goods and services tax, local government tax, road tax for vehicles and others. Middle income earners also need to pay for a number of services to maintain their standard of living and require higher cost such as housing insurance, vehicle insurance, building maintenance and repair, access to utilities, communication and others. For example, the middle and low income groups with monthly earnings of RM2, 500 will pay 3.07 per cent of their income as goods and services tax or GST (Lim & Ooi, 2013). More on, the large group that caught in the affordable housing trap is the middle income group. It is difficult to own a house when the housing prices continue to rise, housing loans approvals are getting stricter and less choices are available for the middle income group (Baqutaya, Ariffin & Raji, 2016).

Table 1

*Distribution of Respondents' Profile (n = 438)*

		Item	Frequency	Percentage
<b>Gender</b>		Male	151	34.5
		Female	287	65.5
<b>Age (year)</b>		20-29	121	27.6
		30-39	211	48.2
		40-49	83	18.9
		50 and above	23	5.3
<b>Marital status</b>		Bachelor	121	27.6
		Married	304	69.4
		Divorced	8	1.8
		Widower	5	1.1
<b>Level of education</b>		PMR	26	5.9
		SPM	95	21.7
		STPM	32	7.3
		Diploma	107	24.4
		Bachelor Degree	157	35.8
		Master	18	4.1
		PhD	3	0.7
<b>Occupation</b>		Government Staff (Professional group)	77	17.6
		Private Staff (Professional group)	48	11.0
		Semi-government staff (Professional Group)	50	11.4
		Government Staff (Support Group)	138	31.5
		Private staff (Support group)	102	23.3
		Semi-government staff (Support group)	23	5.3
		7 to 9	9	2.1
		More than 10	11	2.5
	<b>Estimated Amount of Household's Monthly Income (RM)</b>		RM 4,000 – RM 5,000	290
		RM 5,001 – RM 6,000	5	1.1
		RM 6,001 – RM 7,000	96	21.9
		RM 7,001 – RM 8,000	3	0.7
		RM 8,001 – RM 9,000	10	2.3
		RM 9,001 – RM 10,000	29	6.6

## EVALUATION OF HYPOTHESIS MODEL

Diagram 2 shows the outcome of the hypothesis model analysis that fulfils the criteria of the measurement model evaluation based on the Partial Least Squares Structural Equation Modeling (PLS-SEM) analysis procedure using the software Smart-PLS 3.2.7.



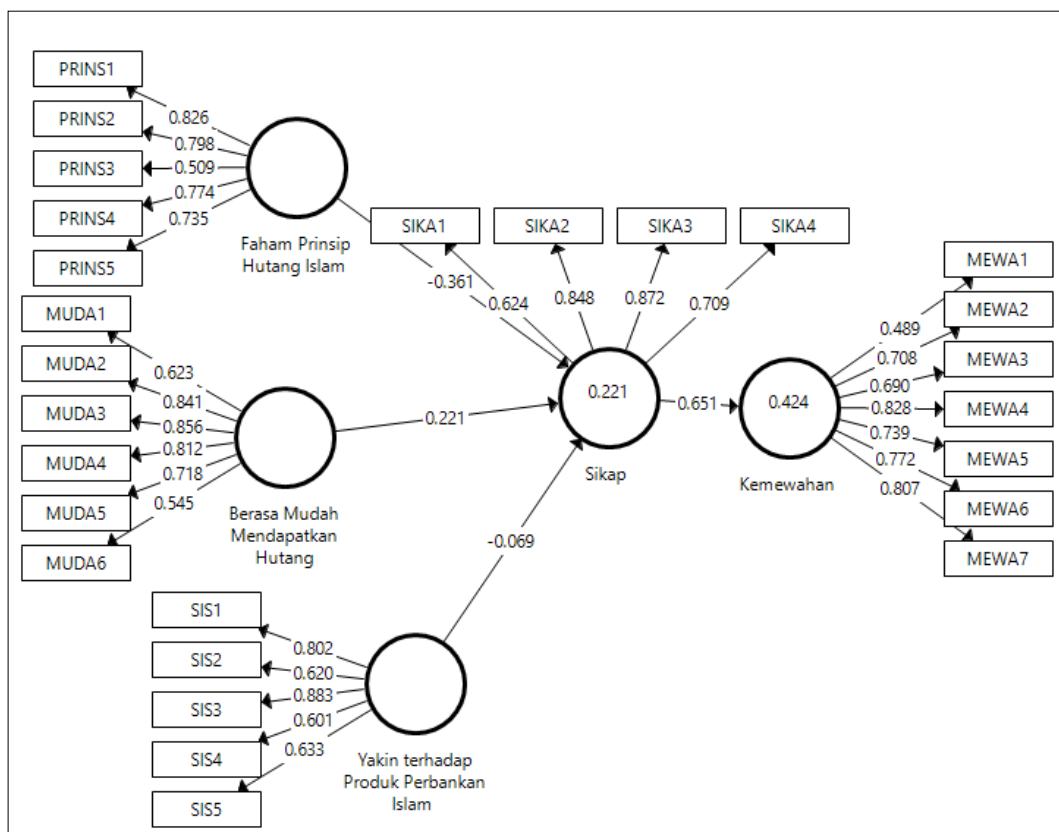

Diagram 2: Evaluation of the Research Measurement Model

### Evaluation of Model Measurement

Table 2 shows the outcome of the measurement model evaluation assessed from four aspects (1) internal validity based on the Cronbach Alpha value and the composite reliability (2) the reliability of every indicator based on the outer loading value, (3) convergent validity based on the Average Variance Extracted (AVE) value and (4) discriminant validity based on the cross loading value, Fornell-Larcker and HTMT criteria (Hair, Hult, Ringel & Sarstedt, 2014).

The evaluation of the internal validity has shown that the Cronbach Alpha value ( $\alpha$ ) and the composite reliability value (CR) for five constructs of the research have exceeded 0.7 at the same time showing a good internal validity. The reliability of every indicator is also achieved based on the outer loading factor more than 0.7. Despite the fact that there are several items with outer loading less than 0.7, all the items are retained as the CR and AVE values have achieved the intended level (Hair et al., 2014). The evaluation of the convergent validity finds that all the research constructs have exceeded the AVE value, so all the constructs have fulfilled the construct validity.

Table 2

*Evaluation of the Research Measurement Model*

Construct	Indicator	Factor Loading	$\alpha$	CR	AVE	Discriminant
<b>Limit accepted</b>		(>0.708)	(>0.7)	(>0.7)	(>0.5)	
<b>Understanding about the Islamic Debt Principles</b>	PRINS1	0.826	0.786	0.853	0.554	Yes
	PRINSI2	0.798				
	PRINIS3	0.509				
	PRINS4	0.774				
	PRINS5	0.735				
<b>Credit facilities offered</b>	MUDA1	0.623	0.838	0.877	0.550	Yes
	MUDA2	0.841				
	MUDA3	0.856				
	MUDA4	0.812				
	MUDA5	0.718				
	MUDA6	0.545				
<b>Confidence towards Islamic banking/financing products</b>	SIS1	0.802	0.768	0.837	0.514	Yes
	SIS2	0.620				
	SIS3	0.883				
	SIS4	0.601				
	SIS5	0.633				
<b>Attitude</b>	SIKA1	0.624	0.763	0.851	0.593	Yes
	SIKA2	0.848				
	SIKA3	0.872				
	SIKA4	0.709				
<b>Luxury</b>	MEWA1	0.489	0.848	0.885	0.528	Yes
	MEWA2	0.708				
	MEWA3	0.690				
	MEWA4	0.828				
	MEWA5	0.739				
	MEWA6	0.772				
	MEWA7	0.807				

Notes:  $\alpha$ =Cronbach Alpha, CR= Composite Reliability, AVE=Convergent Validity

Table 3 shows that discriminant validity is achieved based on the results of the Fornell-Larcker evaluation analysis whereby all the AVE-squared values have exceeded the correlation value shown through the values at the bottom corner of the table.

Table 3

*Fornell-Larcker Criteria*

	(1)	(2)	(3)	(4)	(5)
<b>Credit facilities offered (1)</b>	0.742				
<b>Understand the principles of Islamic Debts (2)</b>	-0.105	0.737			
<b>Luxury (3)</b>	0.286	-0.442	0.727		
<b>Attitude (4)</b>	0.257	-0.414	0.651	0.77	
<b>Confident Towards The Islamic Banking Products (5)</b>	0.037	0.428	-0.155	-0.215	0.717

Table 4 shows the results of the Heterotrait-Monotrait Ratio (HTMT) analysis. The correlation value between constructs is less than 0.85 showing that all the constructs are different from one another (Hair et al., 2014).

HTMT < 0.85

Table 4

*Heterotrait-Monotrait (HTMT) Ratio*

	(1)	(2)	(3)	(4)	(5)
<b>Credit facilities offered (1)</b>					
<b>Understand the principles of Islamic Debts (2)</b>	0.198				
<b>Luxury (3)</b>	0.325	0.507			
<b>Attitude (4)</b>	0.271	0.511	0.771		
<b>Confident Towards The Islamic Banking Products (5)</b>	0.214	0.591	0.196	0.257	

**Evaluation of The Structural Equation Model**

The verification of the structural model is carried out using the bootstrapping procedure with 5000 re-sampling (Hair et al., 2011) using Smart-PLS version 3.2.7 (Ringle et al., 2015) to estimate the significance of the coefficient lines in the research model. Table 5 shows the analysis outcome of the significant relationship between the variables also arranged as the hypothesis testing. The analysis outcome shows that all the relationships tested produce a significant effect on the level of confidence of 5%. The evaluation of the structural model can be seen in Diagram 3.

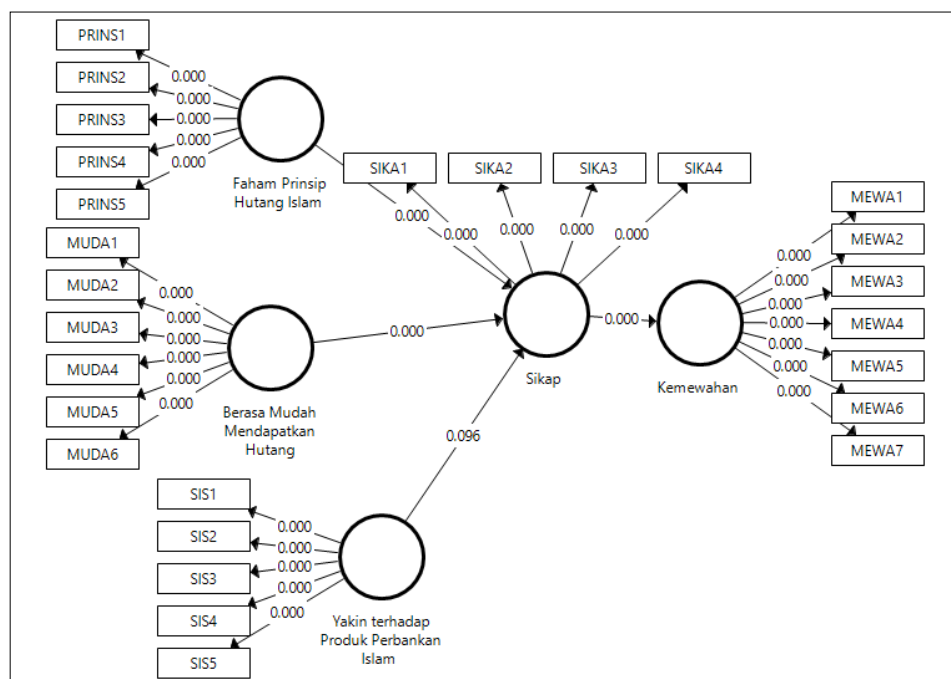

Diagram 3: The Evaluation of the Structural Model

Based on Table 5, the understanding about the principles of debt in Islam gives a significant negative influence towards the attitude of making debts ( $\beta=-0.361$ ,  $t=7.495$ ,  $p=0.000$ ) (Hypothesis 1). The finding shows that the increased understanding of M40 Muslim towards the Islamic debts principles will reduce their tendency to make debts. The finding from Hypothesis 2 shows that the credit facilities offered will give a positive influence towards the attitude of M40 Muslims towards debts ( $\beta=-0.221$ ,  $t=5.603$ ,  $p=0.000$ ). The finding explains that, the easier it is to make debts, the higher the attitude of the M40 Muslims towards debts. The confidence towards Islamic banking/financing products does not influence the attitude of the M40 Muslims towards debts ( $\beta=-0.069$ ,  $t=1.666$ ,  $p=0.096$ ) (Hypothesis 3). Hypothesis 4 shows that the attitude of M40 Muslim gives a positive influence to the purpose of their debt-making which is for luxury ( $\beta=0.651$ ,  $t=22.308$ ,  $p=0.000$ ). The finding shows that the higher the attitude of M40 Muslims towards debt, the higher the purpose to make debt for this single purpose- Luxury.

Table 5

*The Evaluation of the Significance and Relevance of the Relationship In The Structural Model*

Hypothesis	Relationship	$\beta$	t	P	Results
H1	Understand the principles of Islamic debts -> Attitude	-0.361	7.495	0.000	Supported
H2	Credit facilities offered -> Attitude	0.221	5.603	0.000	Supported
H3	Confident towards Islamic banking/financing products -> Attitude	-0.069	1.666	0.096	Rejected
H4	Attitude -> Luxury	0.651	22.308	0.000	Supported

**Moderator Evaluation**

To confirm the effect of the mediator between the relationship determining the behaviour of the M40 Muslims towards the purpose of making debts for luxury, this study refers to the two-step procedure of *bootstrapping* to test the mediator as suggested by Chin (2010). Based on Table 6, the finding from Hypothesis 5 reveals that

Table 6

*Mediator Test Analysis Outcome*

Hypothesis	Relationship	$\beta$	t	P	Results
H5	Understand the principles of Islamic debts -> Attitude -> Luxury	-0.235	6.873	0.000	Mediator
H6	Credit facilities offered -> Attitude -> Luxury	0.144	5.217	0.000	Mediator
H7	Confident towards Islamic Banking/Financing Products-> Attitude -> Luxury	-0.045	1.659	0.098	No Mediator

Based on Table 6, the finding from Hypothesis 5 shows that Attitude has a mediator effect in the Relationship between the understanding about the principles of Islamic debts and making debts for luxury ( $\beta=-0.235$ ,  $t=6.873$ ,  $p=0.000$ ). the finding shows that the higher the understanding of M40 Muslims about Islamic debt principles, the possibility of M40 Muslims to make debts for Luxury is low. Hypothesis 6 shows that attitude has a mediating effect in the relationship between the credit facilities offered and making debts for luxury ( $\beta=0.144$ ,  $t=5.217$ ,  $p=0.000$ ). The finding shows that the easier it is for the M40 Muslims to make debts, the higher the possibility that they would do that for luxurious means. Next, the finding in

Hypothesis 7 shows that attitude does not have any mediating effect between the relationship of the confidence on the Islamic banking/financing products towards the purpose of doing so, for luxury ( $\beta=-0.045$ ,  $t=1.659$ ,  $p=0.000$ ).

### **Discussion and Conclusion**

This study looks into the behavior of the M40 Muslims household to make debts in terms of their understanding on the Islamic Debts Principles, the attitude and the credit facilities offered through the Islamic perspective inspired by the current situations. In a speech delivered by Datuk Seri Azalina Othman Said in the Dewan Rakyat, it is found that the highest number of bankruptcy cases is in Selangor with 72,114 cases (24.30%) as of August 2017 (The Star, 2017). The crises that stem from debt crises automatically leave a negative impact to individuals, families, the society, the country even globally. To date, there are many financial and banking institutions offering loan facilities. Some operate conventionally and some others operate Islamically and are Sharia-compliant. However, the existence of various financial and banking institutions with this facility, be it Sharia compliant or not, does not influence M40 Muslims' indebtedness. This is true, although their understanding about the Islamic debt-making principles is accounted for. In turn, the attitude of being indebted plays an important role in the debt-making behavior of the M40 Muslims be it for necessities or for luxury. This kind of attitude has long been discussed, which is since 1895 where it was discussed with Frank Swetenham. Obviously, the attitude of being in debt is still relevant until today to be connected to the Malays' debt-making behavior. This is proven by the current study's outcome establishing that the attitude towards debts influences the actual debt-making positively, for needs or luxury, among the M40 group. Other than attitude, the understanding about the principles of Islamic debt-making automatically influences the M40 Muslims to make debts, whether for necessities or luxury. A profound understanding about the Islamic debt principles can reduce the possibility of them being indebted.

Other than that, the diverse Islamic banking/financing products offering an easy loaning service are not the reason as to why M40 Muslims are in debt. The main reason is due to their attitude towards debts. This has long been associated with the Malay Muslims and obviously this is still relevant to this very day. Nonetheless, the understanding about the principle of Islamic debts shows a negative relationship towards the debt-making attitude for luxurious purposes.

As the impact of the attitude, Muslims will always be burdened by the issue of debts. Debtors carry a heavy burden in the form of debts in Islam. There are several Hadith related to debt is highlighted due to the Muslim attitude towards debt. The first Hadith is reported by Abu Hurairah: The Messenger of Allah, peace and blessings be upon him, sought a loan for a camel and he repaid it with a better camel, saying, "The best of you are excellent in repayment." This Hadith shows Muslim should pay their debt accordingly though it considered as heavy burden.

Thus, in the events of death, the debt must be paid first before all the will and faraid are carried out and distributed among the family and other inheritors. This has been said in the second Hadith, reported by Salamah ibn al-Akwa': The Prophet, peace and blessings be upon him, was presented with a funeral for him to pray over it. The Prophet said, "Does he have debt?" They said no, so the Prophet prayed over him. Then he was presented with



another funeral and the Prophet said, "Does he have debt?" They said yes. The Prophet said, "Pray over your companion." Abu Qatadah said, "I take responsibility for his debt, O Messenger of Allah," so the Prophet prayed over him.. Further, In the case of the debt of the deceased was not transferred to the family/ companion, his soul is still suspended until his family/ companion help to settle the debt. This is mentioned in the third Hadith reported by Abu Huraira: The Messenger of Allah, peace and blessings be upon him, said, "The soul of a believer remains suspended by his debt until it is paid".

In conclusion, this debt-making phenomenon based on the cases stated requires a compendius, even a perfect, solution to the debtors. Without a comprehensive guideline, a weak understanding about making debts in Islam will encourage the Muslims to make debts unnecessarily, or extravagantly.

### **Corresponding Author**

Murni Yusoff,  
Universiti Sains Malaysia,  
11800 Pulau Pinang,  
Malaysia.  
Email: murniyusoff.usm@gmail.com

### **References**

- Abdullah, A. N. (1985). *Melayu dan tanah: Tumpuan khusus kepada tanah simpanan Melayu*. Kuala Lumpur: Media Intelek Sdn. Bhd
- Abidin, A., Sarmidi, T., & Nor, A. S. H. (2013). Jurang pendapatan dan hutang isirumah. "Dasar Awam Dalam Era Transformasi Ekonomi: Cabaran dan Halatuju". PERKEM VIII Malaysian Economy National Conference Proceeding, (pg. 445-459). Johor Bahru.
- Adzis, A., Bakar, J., & Shahr, H. (2017). Factors influencing young adults' debt in Malaysia. *Journal of Business and Retail Management Research (JBRMR)*, 12 (1)
- Ahmat, S. (1984). *Kedah-tradition and change in Malay State: A study of the economic and political development*. Monograph No. 12. Malayan Branch Royal Asiatic Society, 1778-1923.
- Ahn, T., Ryu, S., & Han, I. (2004). The impact of the online and offline features on the user acceptance of internet shopping malls. *Electronic Commerce Research and Applications*, 3 (405-420).
- Akhyar, A. (2008). *Hutang seronok yang membawa bencana*, Johor Baru: Pustaka Azhar.
- Alidaniah, N. A. R., Sanep, A., Ali, M. N., & Rizki, M. (2015). Gelagat hutang isi rumah mengikut kaum di Bandar Baru Bangi, Selangor. *Malaysia Journal of Society and Space*, 11, 110-119.
- Almenberg, J., Save-Soderbergh, J., & Vestman, R. (2016). Attitudes toward debt
- Amin, H., Rahman, A. R. A., Razak, D. A., & Rizal, H. (2017). Consumer attitude and preference in the Islamic mortgage sector: A study of Malaysian consumers. *Management Research Review*, 40 (1):95- 115. <https://doi.org/10.1108/MRR-07-2015-0159>.
- and debt behavior," Retrieved from [https://www.fi.se/contentassets/02ee7430a0524bf2a09ccfbab350099a/attitudes\\_debtbehavior\\_20170511.pdf](https://www.fi.se/contentassets/02ee7430a0524bf2a09ccfbab350099a/attitudes_debtbehavior_20170511.pdf)
- Badiozaman, R. M. (1975). Malay land reservation and alienation. *Intisari*, 1(2).

- Baqutayan, S. M. S. (2014). The affordable housing stress among middle-income group. *IOSR Journal of Humanities and Social Science*, 19(7), 82 - 90.
- Chen, L. D., & Tan, J. (2004). Technology adaptation in e-commerce: key determinants of virtual stores acceptance. *European Management Journal*, 22 (1): 74-86.
- Chen, L. D., Gillenson, M. L., & Sherrell, D. L. (2004). Consumer acceptance of virtual stores: a theoretical model and critical success factors for virtual stores. *ACM SIGMIS Database*, 35:2: (8-31).
- Cosma, S., & Pattarin, F. (2010). Attitudes, personality factors and household debt decisions: A study of consumer credit. Retrieved on 27 January, 2011, from <http://ssrn.com/abstract=1685765> or <http://dx.doi.org/10.2139/ssrn.1685765>
- Cynamon, B. Z., & Fazzari, S. M. (2008). Household debt in the consumer age: Source growth-risk of collapse. *Capitalism and Society*, 3(2).
- Dar, H. (2002). Islamic house financing in the United Kingdom: Problems, challenges and prospects, *Review of Islamic Economics*, 12, (47-71).
- Davies, E., & Lea, S. E. G. (1995). Student attitudes to student debt. *Journal of Economic Psychology* 16 (4): 663-679.
- Dyck, S., Hansakul, S., & Saxena, R. (2009). Emerging Asia's middle class: A force to be reckoned with. Deutsche Bank Research, Frankfurt, Germany.
- Elias, A. A. (n.d.). Daily Hadith Online. Retrieved from 23 August 2020. <https://abuaminaelias.com/dailyhadithonline/> from <https://e-insolvensi.mdi.gov.my/> on 7<sup>th</sup> January 2017.
- Hair, J. F., Hult, G. T. M., Ringle, C. M., & Sarstedt, M. (2014). *A Primer on Partial Least Squares Structural Equation Modeling (PLS-SEM)*. Los Angeles: USA: SAGE.
- Hair, J. F., Hult, G. T. M., Ringle, C. M., & Sarstedt, M. (2017). *A primer on partial least squares structural equation modeling*. 2nd Edition. Thousand Oaks: SAGE.
- Hair, J. F., Ringle, C. M., & Sarstedt, M. (2011). PLS-SEM: Indeed a silver bullet. *Journal of Marketing Theory and Practice*, 19(2), 139–151.
- Hodari, A. B., Sarmidi, T., & Salleh, N. H. (2014). *Hutang dan golongan muda di Malaysia: Satu kajian awal. Urus tadbir ekonomi yang adil: Ke arah ekonomi berpendapatan tinggi*. High Income Economy National Conference Proceeding (pg. 833-844). Kuala Terengganu, Terengganu.
- IbnKathir. (2008a). Tafsir al-Qur'an al-'Azim: Tafsir Ibn Kathir (Jilid 1). In 'Abd alRezzaq Mahdi (Eds.), Beirut: Dau al-Kitab al-'Arabi.
- IbnKathir. (2008b). Tafsir al-Qur'an al-'Azim: Tafsir Ibn Kathir (Jilid 3). In 'Abd alRezzaq Mahdi (Eds.), Beirut: Dau al-Kitab al-'Arabi.
- IbnKathir. (2008c). Tafsir al-Qur'an al-'Azim: Tafsir Ibn Kathir (Jilid 4). In 'Abd alRezzaq Mahdi (Eds.). Beirut: Dau al-Kitab al-'Arabi.
- IbnKathir. (2008d). Tafsir al-Qur'an al-'Azim: Tafsir Ibn Kathir (Jilid 5). In 'Abd alRezzaq Mahdi (Eds.), Beirut: Dau al-Kitab al-'Arabi. Ibn Kathir. (2008e). Tafsir al-Qur'an al-'Azim: Tafsir Ibn Kathir (Volume 6). In 'Abd alRezzaq Mahdi (Eds.), Beirut: Dau al-Kitab al-'Arabi.
- Ismail, A. H. (1992). Bank Islam Malaysia Berhad: Principles and operations in Sheikh Ghazali Sheikh Abod et al (eds), *An introduction to Islamic Finance*. Kuala Lumpur. Quill Publishers.
- Jusoh, M. K. A. (2014). *Konsep hutang dalam Islam: Satu kajian terhadap kefahaman dan amalan kakitangan UiTM* (Unpublished thesis). Universiti Sains Malaysia.
- Kamleitner, B., & Kirchler, E. (2007). Consumer credit use: a process model and literature review. *Revue europeenne de psychologic appliquée*, 57 (4): 267-283

- Khairuldin, W. M. K. F. W., Hassan, S. A., Anas, W. N. I. W. N., Mokhtar, W. K. A. W., & Embong, A. H. (2020). Al-Takyif Al-Fiqhi and its application in Islamic research methodology. *Journal of Critical Reviews*, 7(7), 462-467.
- Lim, K. H., & Ooi, P. Q. (2013). *Implementing goods and services tax in Malaysia*. Penang Institute.
- Lu, L.C., Chang, W. P., & Chang, H. H. (2014). Consumer attitudes toward bloggers' sponsored recommendations and purchase intention: The effect of sponsorship type, product type and brand awareness. *Computers in Human Behavior*, 34 (258-266).
- Malaysian Insolvency Department. (2017). Peratus Kebankrapan Mengikut Negeri. Retrieved
- Rahim, N. M. Z., Suliaman, I., & Razzak, M. (2012). *Kesempitan hidup penghutang: Analisis ayat 280 surah al-baqarah*. Proceedings: The 2nd Annual International Qur'anic Conference. (pg. 114-126).
- Ringle, C. M., Wende, S., & Becker, J. M. (2015). SmartPLS 3. Boenningstedt:SmartPLS GmbH. Retrieved from <https://www.smartpls.com>.
- Sipon, S., Othman, K., Ghani, Z., & Radzi, H. (2014). The impact of religiosity on financial debt and debt stress. *Procedia - Social and Behavioral Sciences* 140 (2014) 300-306.
- Sobian, A., & Rahman, S. F. (2010). *Pinjaman peribadi: Hasil kajian terhadap masyarakat Malaysia*, Kuala Lumpur: Institut Kefahaman Islam Malaysia (IKIM).
- Swettenham, F. A. (1895). *Malay sketches* (3rd. Ed). London and New York: John Lane The Bodley Head.
- Tahir, R., & Yusof, S. (2014). Status Individu Muflis dalam Asnaf Al-Gharimin. *International Journal of Business and Technopreneurship*, 4 (3): 477-494.
- Wang, L., Lu, W., & Malhotra, N. K. (2011). Demographics, attitude, personality and credit card features correlate with credit card debt: A view from China. *Journal of Economic Psychology* 32 (1): 179-193.
- Zakaria, R. H., Kader, R., Jaafar, N. I., & Marican, S. (2012). Burgeoning household debt: An Islamic economics perspective. *Middle-East Journal of Scientific Research*, 12(9), 1182-1189, doi:10.5829/idosi.mejsr.2012.12.9.267.