

Develop and Validate the Creativity Practice of Engineering Drawing Teachers (CPT-ED) Implementing Teaching and Learning Framework

Suriana Ngatiman¹ Muhammad Sukri Saud²

Faculty of Educational Sciences and Technology, ^{1&2} Universiti Teknologi Malaysia, 81310
Johor Bahru, Johor Malaysia,

Email: alsuriana782@yahoo.com & p-sukri@utm.my

To Link this Article: <http://dx.doi.org/10.6007/IJARBSS/v15-i1/24362> DOI:10.6007/IJARBSS/v15-i1/24362

Published Date: 17 January 2025

Abstract

The development of the world of education requires teachers to play a more creative role and not be tied to one way in implementing Teaching and Learning (TL). In this regard, teachers must be wise to change their attitudes and self-practices to face any changes in line with the transformation of the current education system. Therefore, awareness and importance of the practice of creativity in teaching should be given priority and developed comprehensively by diversifying strategic approaches and techniques of TL delivery. This study aims to develop and validate the Engineering Drawing Teacher Creativity Practice Framework (CPT-ED) Implementing TL. To complement this study, a mixed approach (Mixed Method) was an option in the design of the study. Sequential Mixed Methods of Exploration to explore constructs, sub-constructs and elements of the CPT-ED Framework Implement TL at the qualitative study phase stage. However, this study only focuses on the quantitative phase, which is to develop and validate the research framework by using two data analysis methods, namely Exploration Factor Analysis (EFA) and Validation Factor Analysis (CFA) which are analyzed using IBM-SPSS AMOS 23 software. The data was collected using a six-point Likert scale questionnaire from 300 teachers comprising ED teachers at nine SMTs across Malaysia and teachers who taught Technical Communication Graphics (TCG) subjects on Secondary School Day in Malaysia. Sternberg's Theory of Creativity is used as a reference for the development of research frameworks. This research highlights how teachers' creative practices in implementing TL improve the effectiveness and smoothness of the overall teaching process and provide a meaningful experience to students. The findings of the study show that there are three sub-constructs and eleven elements of the TL of CPT-ED Implementation. The findings also show that the listed CPT-ED Implementation TL framework has met the appropriate model characteristics and has been validated. This study was conducted because of the importance of creativity in teaching as well as the need for guidance

and reference for creative teaching practices, especially for the subject of Engineering Drawing (ED) based on the research problems that have been identified.

Keywords: Develop, Validate, Framework, Practice, Creativity, Implement

Introduction

Teachers' creativity cannot be taught, but applied indirectly through teaching activities by practicing creativity practices in a planned and orderly manner (Dagang, 2016; Sahrir et al., 2020). Based on a study conducted by Ahmad & Jingga (2015) and Brauer et al., (2024), there is a relationship between the level of teacher creativity and the practice of creativity in teacher teaching. Therefore, awareness of the potential of creativity and its practice is needed to increase the level of creativity of teachers to achieve learning objectives. Effective and quality teaching planning and implementation is the most important thing to transform education and increase student outcomes (Patfield et al., 2022; Hamdan et al., 2021). This statement is in line with the findings of the study Batjo & Ambotang (2019). It was found that there was a significant influence between the success of students and the quality of teachers' teaching. Moving on The quality of teachers' teaching is also influenced by teachers' creative practices in determining the success of a student (Batjo & Ambotang, 2019).

Engineering-related subjects require a creative teaching approach by teachers to ensure that students are guided to familiarise themselves with creative activities as well as the ability to analyze and evaluate problems related to engineering (Daly et al., 2014). Therefore, ED teachers need to have a clear understanding of creativity and especially in implementing TL (Yasin et al., 2012; Saad & Saud, 2022). Therefore, teachers should have the knowledge, understanding and skills to master creativity in teaching to enable the TL process to be carried out with enthusiasm, motivation and effectiveness (Seng & Othman, 2018).

However, there are challenges for ED teachers to practice creativity when planning and implementing TL due to the absence of specific guidance in accordance with the needs of ED subjects (Yasin et al., 2012; Saad & Saud, 2022). In addition, there are also obstacles for ED teachers to implement TL creatively due to the need to complete the syllabus and a lot of subject content due to limited time (Saadiman, 2018; Samsudin et al., 2013; Yasin et al., 2012). However, the problems that arise related to the lack of creativity of teachers Implementing TL illustrate that the level of teacher teaching creativity practice is still at a moderate level that requires attention (Corazza et al., 2021). In this regard, research related to the understanding and practice of creativity of teachers implementing TL requires full exploration to ensure the effectiveness of TL. Therefore, an CPT-ED Implementing TL framework was developed based on the teaching needs of ED teachers and student learning.

Literature Review

Sternberg's Theory of Creativity: A Guide for Teachers to Practice Creativity in Implementing TL

This article examines the practice of teacher creativity in Implementing TL. Sternberg's Theory of Creativity was chosen to underlie this study. This theory provides a structured perspective on how creativity can be nurtured and practiced, especially in implementing TL. This study has placed six variables that are conditions to enable an individual to be creative based on intelligence, knowledge, thinking style, personality, motivation and environmental conditions can form the construct, sub-construct and elements of teacher teaching creativity

practice. It is hoped that the variables listed can complement and refine the theoretical framework of this study and subsequently be able to develop a more comprehensive CPT-ED Implementing TL Framework and can be used as a guide for teachers to practice creativity in their teaching. In the context of the practice of teacher teaching creativity based on Sternberg's Creativity Theory, it shows the important role of teachers in nurturing and developing creativity in them. Among the important points that have been identified based on this theory are variables that can arouse teachers' intelligence, encourage creative thinking styles, foster openness and courage, increase motivation and create an appropriate learning environment (Gralewski & Karwowski, 2018).

Sternberg's theory of creativity is also a guide for teachers to understand and increase motivation to practice creativity in teaching. In addition, teachers need to always be motivated to set goals clearly in their teaching. In addition, the determination and establishment of a conducive learning environment is an important factor in encouraging teachers' creativity. Teachers need to ensure that a comfortable learning environment is needed to generate creative thinking including reducing barriers such as strict rules or bureaucratic regulations that can hinder creativity in the TL process (Brouwers & Vijver, 2015). In this regard, the role of teachers adapting creative elements such as synthetic activities, practical projects, and various assessments is very important in implementing teaching (Rushdi & Amran, 2020). Therefore, the findings of the study also show that CPT-ED Implementing TL is mostly influenced by the knowledge, motivation and environment of teachers in adapting Sternberg's creativity theory.

The Importance of Teachers' Creativity Practices in Teaching and Learning

Implementing Teaching is a structured practice by teachers to facilitate the transfer of knowledge, skills and interpersonal abilities to students (Shalihet et al., 2022; Fischer & Barabasch, 2023). Meanwhile, implementing learning is a dynamic process of individuals acquiring new understandings, knowledge, skills, values, and attitudes (Xhomara & Uka, 2022). However, implementing TL is an interactive process that complements the roles of teachers and students with the aim of fostering understanding, critical thinking and knowledge development. In the context of this study, implementing TL refers to teachers' creativity in relating lesson content to real situations, controlling students' concentration in the learning process as well as creating an environment that encourages creative activities for more meaningful learning.

The practice of teacher creativity Implementing creative TL refers to the role of teachers in utilizing new, innovative teaching approaches or strategies and using imagination in delivering subject content (Sarifuddin & Ahmad, 2023; Xue et al., 2023; Vilarinho-Pereira et al., 2021). Therefore, the approach of relating subject theory to real-life situations can strengthen students' mastery of a subject concept being taught (Afriandani et al., 2019). Furthermore, this practice can also encourage students to relate the content of the lesson to their knowledge and real life (Andila et al., 2021; King & Ritchie, 2013). In addition, teachers' creativity using the field visit method is also an innovative teaching method (Tall, 2019) and has been recognized as a strategy that can help improve students' understanding of a concept. The visit method can also create a new learning environment to explain a concept in the form of a real situation and be able to establish expertise sharing with relevant parties (Observation & Han (2019). In this regard, the ability of teachers to manage external expertise

sharing programmes can also increase the motivation of teachers to strive to build a network of relationships as well as shape the transformation of the school, thereby improving the learning performance of students (Saidin et al., 2016; Vinathan, 2016). Through this programme, the involvement of parties, educational institutes, industry and communities related to the suitability of the subjects taught is either aimed at sharing facilities, technology or knowledge. Meanwhile, the influence on the importance of innovation, technology and teachers' readiness to improve professionalism is very important to encourage them to implement external expertise sharing programs to increase motivation and readiness to diversify teachers' teaching strategies (Timbang & Ambotang, 2020).

Meanwhile, teachers' efforts to diversify the use of creative induction sets in implementing TL can also increase students' focus and interest in teacher teaching (Putri et al., 2020; Mahlianurrahman & Aprilia, 2022). Along with the latest technological developments, the development of video-based educational media with a combination of relevant audio messages, visual cues and graphics can convey information in an attractive, clear and easy-to-understand manner at the beginning of teachers' teaching (Liu & Elms, 2019). The application of this technology also highlights the importance of teachers diversifying creative induction sets, based on Information and Communication Technology (ICT) to enhance the learning experience and control students' focus from the early stages of TL, thereby enabling teachers to attract students' interest and encourage active involvement in the learning process.

In this regard, teachers' creativity in applying teaching techniques in accordance with the content of the subject also needs to be paid attention to by teachers in order to actively involve students and become an important factor to facilitate the learning process (Rrustemi & Sylaj, 2022). Therefore, innovative learning such as student-centred teaching, project-based learning, project production, discussions and group work can increase overall student involvement in active learning (Cao et al., 2021). Meanwhile, to create comfort in the TL process, the teacher's humor or humor approach can reduce tension and create good interaction, increase motivation and can encourage students' concentration throughout the learning process (Tunnisa et al., 2019; Yusuf et al., 2021). In addition, it can also help students learn more comfortably and remember more. In addition to reducing anxiety over difficult subjects, the use of humor elements can also build an engaging and enjoyable learning environment (Strean, 2011; Yagan & Kaya, 2022). However, the use of humor in teaching practices requires consideration and adjustment to the needs of the lesson content in order to create a positive impact on students (Abdul Aziz et al., 2013).

In addition, the effectiveness of teacher delivery also depends on teachers' efficiency in handling technology and digital skills to enable them to diversify teaching methods and improve the quality of implementing TL (Ling & Kutty, 2022). The use of technology in teaching has also been found to have a positive impact on student control and achievement and thus play an important role in transferring knowledge whether face-to-face or online (Kit & Mahmud, 2023). In addition, effective teaching also depends on the implementation of creative learning activities as well as careful planning and implementation to stimulate students' creativity (Kimpa & Salamuddin, 2022). Therefore, guided by planned TL activities, it can increase the active involvement and cognitive abilities of students and contribute to more controlled teaching (Sanuddin & Hashim, 2018). In addition, teachers' creativity in

implementing TL prioritizes good time management to enable teachers to streamline the process of implementing teaching by paying attention to the entire lesson content (Khanam et al., 2017; Claessens et al., 2007). Therefore, effective time management not only makes the TL process organized and planned but also helps students become more focused throughout the learning session and can increase student concentration and engagement (Afenu et al., 2021).

In an effort to improve the quality of TL in line with 21st century education, teachers need to apply various teaching methods and strategies, set innovative and creative training in accordance with diverse learning environments (Hamzah et al., 2022; Sarifuddin & Ahmad, 2023). The emphasis on the importance of providing a complete learning space with the latest learning facilities can also create a conducive learning environment and enable students to feel comfortable and enjoy learning (Mustaffa et al., 2021a; Maarof et al., 2022). In addition, teachers' efforts to create a conducive learning environment show the creative role of teachers in diversifying pedagogy to meet the diversity of students in the classroom (Mustaffa et al., 2021b; Sherpa, 2020). The application of culturally responsive practices in the classroom can also create a positive environment by respecting and integrating diversity of backgrounds and cultures (Vakil et al., 2023; Castro, 2010). Furthermore, teachers' creativity in implementing learning outside the classroom is also seen to provide experience and application to the real environment and provide authentic learning outside the classroom (Nor Pazilah et al., 2014; Dare et al., 2021). Through the implementation of learning outside the classroom, it can also emphasize the creativity and involvement of teachers in managing learning informally and requires a willingness to implement directed learning in a controlled environment (Dagang, 2016; Mokhtar et al., 2018).

Finally, students' involvement in the management of learning or extracurricular activities also has an impact on holistic development, including the improvement of interpersonal skills and the development of students' personalities (Abu Samah et al., 2022). In this regard, through efforts to involve students in the management of the learning environment, it is also seen that it can foster students' leadership attitude and responsibility (Madzalan et al., 2022).

Study Aim

This study aims to develop and validate the CPT-ED Implementing TL Framework.

Study Methodology

To complete this study, a combined approach (Mixed Methods) as an option in the design of the study conducted. Sequential exploration combined method (Exploratory Sequential Mixed Method) to explore the constructs, sub-constructs and elements of the CPT-ED Framework for Implementing TL at the qualitative study phase stage. However, this study only focuses on the quantitative phase of developing and validating the study framework. To complete the study, a questionnaire using a 6-point Likert scale was used. Selection of methods using links google form through the giving link The questionnaire was also chosen because it is very suitable for limited movement and takes into account the security situation and the ability to access the form at any time with the help of the internet as recommended by Fricker (2012). For the purpose of quantitative data collection, the population of this study consists of all ED teachers in nine SMTs throughout Malaysia and teachers who teach the

subject of Technical Communication Graphics (TCG) in Secondary School Day in Malaysia. For the purpose of the study sample selection process, the staged sampling technique (Multistage Sampling) was used for the purpose of completing the sampling process of this study. In accordance with the recommendations Etikan & Bala (2017), the staged sampling technique combines several techniques for effective and efficient sampling. The choice of this technique is because it involves a relatively large population covering a large geographical area (Ethics & Bala, 2017; Neuman, 2011). In this regard, the selection of this multi-sampling technique, using the cluster sampling technique and break down the study population into groups or zones to conduct studies over a wide geographic area. The total number of respondents involved was 300 people. The Exploration Factor Analysis (EFA) and Validation Factor Analysis (CFA) methods of IBM-SPSS AMOS 23 software were used to complete this study.

Findings and Discussion

EFA Analysis Findings

To develop the CPT-ED Implementing TL framework, the researchers used the EFA analysis method to group the elements in one sub-construct. Accordingly, an EFA analysis was conducted referring to each sub-construct element contained in the constructed framework. There are three sub-constructs contained in the teacher's creativity practice construct of Implementing TL, namely implementing relevant activities (CA), controlling student concentration (CB) and providing an environment that encourages the creative process (CC). Accordingly, the results of the analysis of the three factors involved are collected and elaborated in one table. The summary of the KMO Table and Bartlett's Test of Sphericity for the sub-constructs contained in the creativity practice construct of teachers implementing TL is shown in Table 1 referring to the results of the exploratory factor analysis, it was found that the KMO value for the three sub-constructs of teacher creativity practice Implementing TL was above 0.6 which ranged from 0.624 to 0.687. While the values of Bartlett's Test for the CA, CB, and CC constructs (Chi-Square = 38.666, 41.562 and 23.190) and p-value = 0.000 for the three sub-constructs. These findings show the adequacy of sampling to conduct factor analysis on all sub-constructs of teachers' creativity practices in Implementing TL.

Table 1

KMO Schedule and Bartlett's Test for constructs Implementing TL

KMO and Bartlett's Test		CA	CB	CC
Kaiser-Meyer-OEDin Measure of Sampling Adequacy.		0.687	0.682	0.624
Bartlett's Test of Sphericity	Approx. Chi-Square	38.666	41.562	23.190
	Df	10	10	10
	Mr.	0.000	0.000	0.000

Next, Table 2 shows the matrix component table which combines the three sub-constructs of the teacher's creativity practice of Implementing TL, it is found that all elements from CA1 to CA5 have a factor weighting range ranging from 0.643 to 0.793. Meanwhile, elements CB1 to CB5 have a factor-weighting range ranging from 0.641 to 0.744 and elements CC1 to CC5 have a factor-weighting range ranging from 0.603 to 0.756. All weighting ranges achieved by all elements contained in the construction of teachers' creativity practices in implementing TL exceeded a value of 0.6. These findings also show that all elements can explain well the sub-constructs contained in the construction of teachers' creative practices in Implementing TL.

Table 2

Components and weighting values for the construction of Implementing TL

	CA Component	CB Component	CC Component
CA1	.669		
CA2	.643		
CA3	.684		
CA4	.693		
CA5	.793		
CB1		.712	
CB2		.641	
CB3		.744	
CB4		.669	
CB5		.719	
CC1			.603
CC2			.745
CC3			.676
CC4			.604
CC5			.756

These findings also show that all elements can explain well the sub-constructs contained in the Implementing TL construct.

Factor Validation Analysis (CFA) Findings

The Factor Validation Analysis (CFA) was carried out to test the validity of the elements that are indicators to measure the sub-constructs and constructs of Implementing TL. Accordingly, the Analysis of the Measurement Model on the construct of teachers' creative practices in Implementing TL is explained one by one based on the sub-constructs and elements that have been listed. CFA analysis for each sub-construct element is carried out to ensure that the model matches the study data. There are three sub-constructs contained in the construct of teachers' creativity practice of Implementing TL, namely: Implementing Relevant Activities (CA); Controlling Pupil Concentration (CB) and Providing an Environment Encouraging Creative Process (CC). An explanation of the findings of the Measurement Model Analysis for each sub-construct is presented in the sub-heading below. An explanation of the findings of the Measurement Model Analysis for each sub-construct is presented in the subheading below.

Figure 1 shows the initial measurement model of the sub-construct of teachers' creativity practice in Implementing Relevant Activities consisting of five elements (CA1, CA2, CA3, CA4, CA5). Analysis of the initial measurement model shows a rather weak fit model. The findings showed that four out of five elements recorded a factor weighting of more than 0.6, while the CA1 element obtained a weighting factor value of 0.56 which is less than 0.6 and should be removed from the list of elements. The study also found that the fitness indexes still did not reach the minimum values because the values of RMSEA= 0.210 (>0.08) and Chisq/df = 4.87 (>3.0). Accordingly, with reference to the modification Indices, the researcher took steps to modify the CA2 and CA4 element pairs which have a high measurement error

value of 29.782. Therefore, the CA4 element was dropped and the CFA analysis was re-conducted.

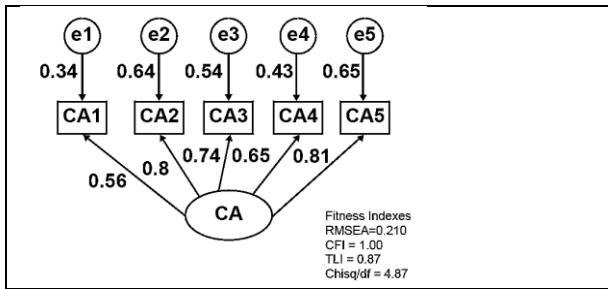

Figure 1 Initial Measurement Model of Sub Construct Implements Relevant Activities.

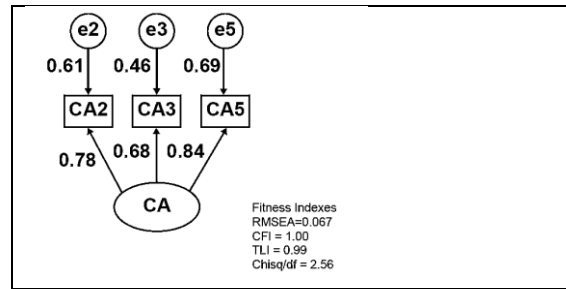

Figure 2 Final Measurement Model of Sub Construct Implements Relevant Activities.

Referring to Figure 2, the CFA analysis was re-run after performing the removal of CA1 and CA4 elements. The researchers found that this final measurement model had been able to meet the set criteria and showed that the fitness indexes reached the minimum values of RMSEA= 0.067 (<0.08), CFI = 1.00 (>0.9), TLI= 0.99 (>0.9) and Chisq/df = 2.56 (<3.0). Findings of the analysis of the validity and reliability of the Sub-construct of Implementing Relevant Activities. The results showed that the validity of convergence through AVE value was 0.79 (>0.50) and composite reliability through C.R value was 0.70 (>0.6). In this regard, the measurement model of the Implementing Relevant Activities sub-construct shows good validity and reliability.

(b) Measurement Model of Sub Construct Controlling Pupil Focus (CB)

The initial measurement model of the Controlling Pupil Concentration sub-construct consists of five elements (CB1, CB2, CB3, CB4, CB5) as shown in Figure 3. The analysis of the initial measurement model showed that the fit model was relatively weak even though all elements showed a factor weighting of more than 0.6. The study found that the fitness indexes still did not reach the minimum value because the value of RMSEA= 0.431 which was above 0.08 and Chisq/df = 4.13 (>3.0). In this regard, referring to the modification Indices, the researcher took steps to modify the CB3 and CB4 element pairs which have a high measurement error value of 27.58. Therefore, the CB3 element was eliminated due to low factor weighting and CFA analysis was re-conducted.

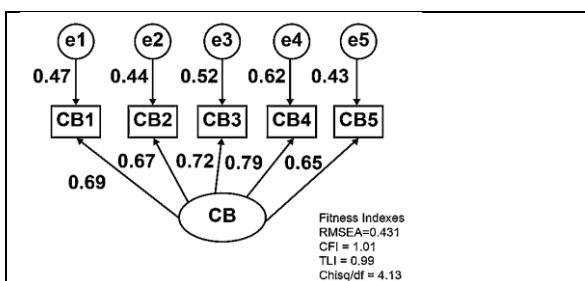

Figure 3 Sub-construct Initial Measurement Model Controls Pupil Concentration

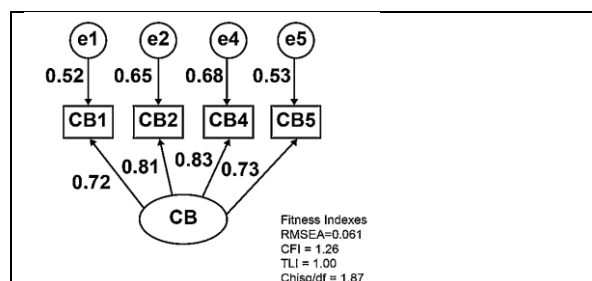

Figure 4 Final Measurement Model of Sub Construct Controlling Pupil Focus

Next, Figure 4 shows the findings of the CFA analysis which was re-conducted after the removal of the CB3 element. The researchers found that this final measurement model

had met the set criteria and showed that the fitness indexes reached the minimum values of RMSEA= 0.061 (<0.08) and CFI = 1.26 (>0.9), TLI= 1.00 (>0.9) and Chisq/df = 1.87 (<3.0). Furthermore, the results of the analysis of the validity and reliability of the sub-construct of Controlling Pupil Concentration also showed that the validity of convergence through the AVE value of 0.71 (>0.50) and the reliability of the composite through the C.R value was 0.98 (>0.6). Accordingly, the measurement model of the Controlling Pupil Concentration sub-construct shows good validity and reliability.

(c) Sub-construct Measurement Model Provides an Environment Promoting Creative Process (CC)

Figure 5 shows the initial measurement model of the sub-construct Providing an Environment to Promote the Creative Process which consists of five elements (CC1, CC2, CC3, CC4, CC5). Analysis of the initial measurement model shows a rather weak fit model. The findings also showed that the CC1 element recorded a factor weighting reading of less than 0.6. Therefore, the researcher has taken steps to remove the CC1 element. However, it was found that the fitness indexes still did not reach the minimum value because the value of RMSEA= 0.098 which is above 0.08 and Chisq/df = 3.671 (>3.0). Accordingly, with reference to the modification Indices, the researcher took steps to constrain the element pairs that showed high measurement error values of e3 and e4 as well as the pairs e4 and e5. Once constraints are created, the CFA analysis is re-run.

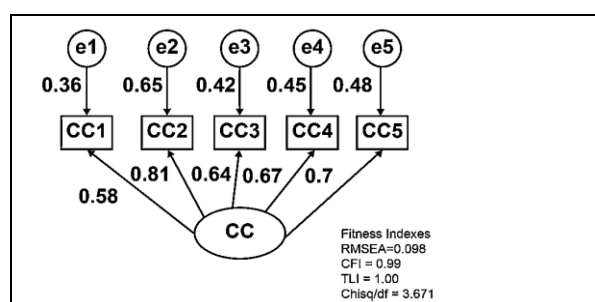

Figure 5 Sub-construct Initial Measurement Model Provides an environment that promotes creative processes.

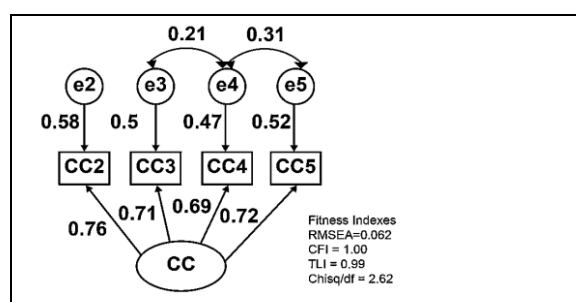

Figure 6 The final measurement model of the sub-construct provides an environment that promotes the creative process.

Meanwhile, Figure 6 shows the findings of the CFA analysis which was re-conducted after removing the CC1 element. The researchers found that this final measurement model was able to meet the set criteria and showed the fitness indexes with a minimum value of RMSEA= 0.062 (<0.08) and CFI = 1.00 (>0.9), TLI= 0.99 (>0.9) and Chisq/df = 2.62 (<3.0). The findings show that the analysis of the validity and reliability of the sub-construct provides an environment that promotes the creative process. The results showed that the validity of convergence through AVE value was 0.78 (>0.50) and composite reliability through C.R value was 0.970 (>0.6). In this regard, the measurement model of the sub-construct Providing an Environment Promotes Creative Process shows good validity and reliability.

After the CFA analysis for the measurement model for each sub-construct contained in the construct of the teacher's creativity practice of Implementing TL is carried out, the process of evaluating the measurement model from the aspect of validity and reliability of a measurement model continues. Therefore, the researcher carried out the measurement of

the combination of all elements and sub-constructs simultaneously after the CFA analysis was carried out for each measurement model by taking into account the unidimensionality, validity and reliability of each construct of the teacher's creativity practice Implementing TL. Figure 7 shows the combined CFA (Pooled CFA) of the teacher's creative practice construct of Lesson Planning. The findings of the pooled-CFA procedure for the entire Implementing TL construct are as follows:

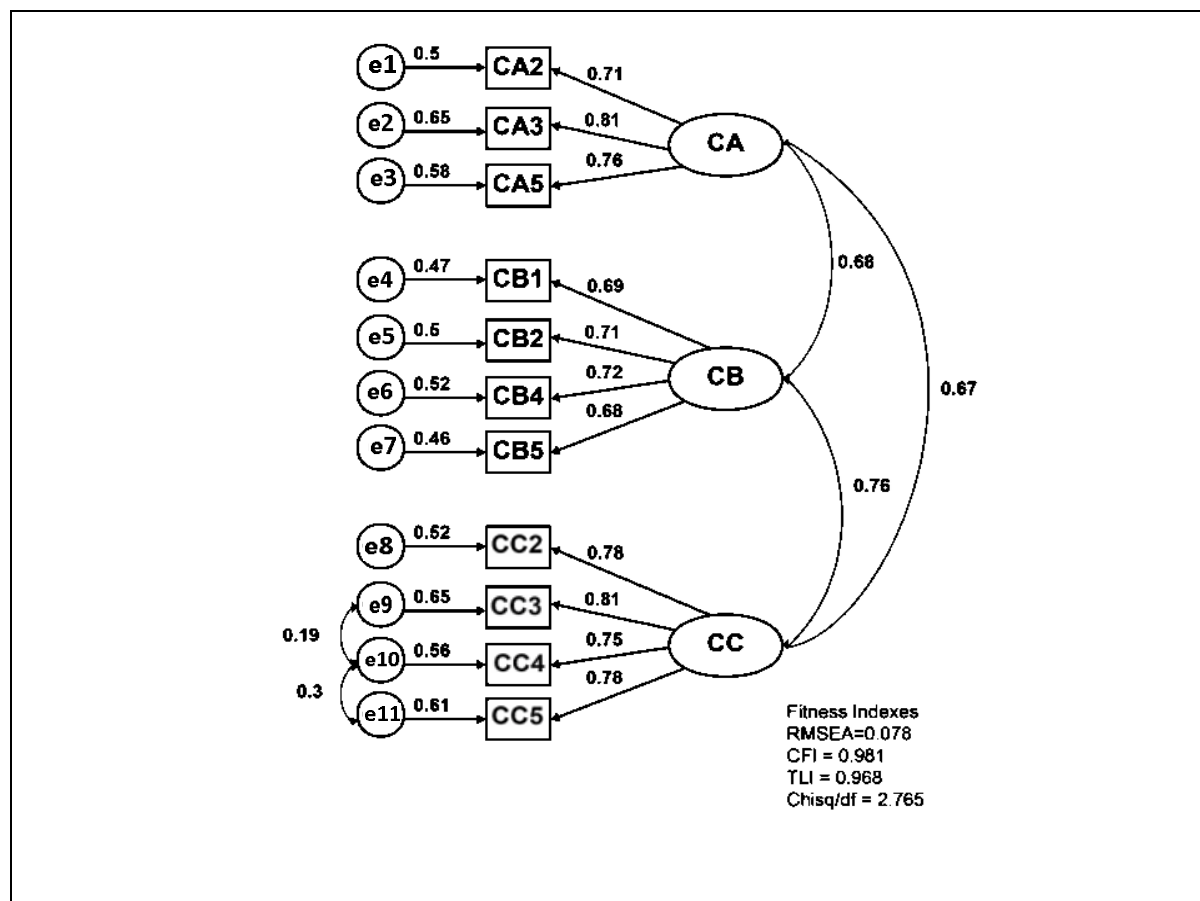

Figure 7 Analysis of Pooled CFA Constructs Implementing TL

Figure 7 also shows that the correlation value of the combination of sub-constructs that make up the Implementing TL construct achieves a good correlation value of between 0.67 to 0.76 which is less than 0.85. Therefore, no multicollinearity problem was identified for the Implementing TL construct.

After the calculation of AVE and CR values is carried out, an assessment of the normality of the data distribution is carried out to ensure that the data collected are scattered normally. The results of the normality test showed that the skewness value was in the range of -1.5 to +1.5. Meanwhile, the kurtosis value is between -7.9 to +7.0. The findings also show that the data obtained are scattered normally and are suitable for SEM analysis. After the validity, reliability and normality tests were carried out, the next analysis was to concentrate on Maximum Likelihood Estimates Regression weight, Squared Multiple Correlation analysis, model fit analysis, covariance and correlation analysis were conducted. The study found that the Critical Ratio (CR) values for all elements of the indicator ranged from -1.96 to +1.96. Accordingly, this study shows that all the elements of the indicator are significant to the study

construct. Next, the standardized regression weight showed that all elements of the indicator recorded values in the range of 0.690 - 0.894. The regression values obtained show that all indicators can significantly represent the sub-constructs contained in the CPT-ED Implementing TL Framework. This study also found that all Squared Multiple Correlation (SMC) values for the elements of the CPT-ED Implementing TL Framework are above 0.3 values, which indicates that all these elements can measure the sub-constructs and constructs of CPT-ED Implementing TL.

To complete this study, the findings of the model matching analysis were also carried out and shown in Table 3. The model fit test includes the Goodness of fit Square Test, Baseline Comparison and RMSEA values are referenced to ensure that the model fit is in line with the study data obtained. The Baseline Comparison value should be above 0.90, while the RMSEA value should be less than 0.08 and prove that the proposed framework model is significant with the study data.

Table 3

Fit Summary Framework for Creativity Practice in Implementing TL ED Teachers

Model	NFI Delta 1	RFI rho1	IFI Delta2	TFI rho2	CFI	RMSEA
Default Model	.845	.853	.967	.954	.978	0.068
Saturated model	1.000		1.000		1.000	
Independence Model	0.00	0.00	0.00	0.00	0.00	

Table 3 also shows that the NFI (Normal Fixed Index), RFI (Relative Fix Index) values obtained show that the values obtained are less than 0.9 while IFI (Incremental fit), TFI (Tucker-Lewis Fix Index) and CFI (Compare Fix Index) reach values above 0.90. Next, the RMSEA (Root Mean Square Error of Approximation) value obtained is 0.068 which is less than 0.08. These findings also confirm that the skeletal model constructed is significantly consistent with the study data.

Overall, it can be concluded that the CPT-ED Implementing TL Framework developed has met the characteristics of a good model fit and has been verified. Therefore, the framework for practicing creativity of teachers implementing TL can be officially adopted by all ED teachers as a reference for practicing creativity in teaching. A summary of the final framework based on the EFA and CFA analyses is shown in Figure 8.

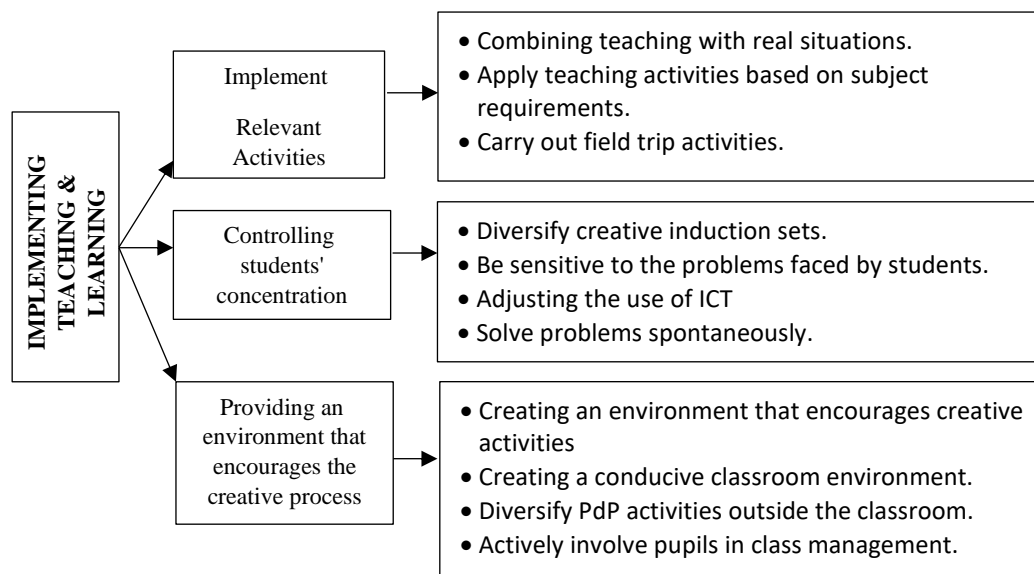

Figure 8 Details of CPT-ED Framework for Implementing TL

The data analysis process of this study involves the procedure of grouping elements in one sub-construct to ensure the adequacy of sampling using EFA analysis. Furthermore, the proposed framework of the CPT-ED obtained has been validated using the CFA analysis method. Validity and reliability through SEM analysis have found that four sub-constructs and consisting of 11 elements in the developed Implementing TL construct have met the characteristics of a good model fit to form the CPT-ED Implementing TL framework.

Discussion

The validation factor analysis was carried out to prove that the constructs, sub-constructs and elements obtained from the findings of the qualitative study were valid and reliable. There are two types of analyses that have been carried out to ensure the matching of measurement models based on the findings of the study. For the first analysis, the measurement model for each sub-construct and framework element of AKPG Implementing TL was carried out CFA analysis. At this stage, only measurement models that achieve the set match index are accepted. The reference used to achieve this purpose is to refer to elements or items that have a weighting factor of less than 0.6 dropped. Meanwhile, the convergent validity and composite reliability of each element are also referenced and ensured to reach the minimum values set as proposed by Awang (2015) and Hair et al., (2014)

In the first stage, CFA analysis was carried out on the elements contained in each sub-construct that represented the AKPG Implementing TL construct. Next, the analysis of the validation factor involving the combination of all elements for each sub-construct is carried out in a Pooled-CFA manner to ensure that there is no multicollinearity problem based on the correlation value obtained at the initial stage before proceeding to the next stage. Next, the combination of the three sub-constructs is done in a pooled-CFA manner again to determine the correlation value between the sub-constructs to ensure that there are no multicollinearity problems. The findings show that the CPT-ED Implementing TL construct listed has met the characteristics of a good model fit and has been validated.

In this regard, the framework of the AKPG Implementing TL consists of 3 sub-constructs and 11 elements. The overall findings from the CFA process have eliminated 4 elements in the initial framework of CPT-ED Implementing TL by taking into account the failure factors of compliance with model fit characteristics and framework development. However, overall, the CPT-ED Implementing TL framework developed was found to meet the characteristics of model fit (model fit) based on the CFI, NFI, TLI value index which also achieved good fit values and has been validated. Therefore, these findings can also be used as a guide for ED teachers to practice creativity in implementing TL, namely by implementing relevant activities while implementing TL, controlling students' concentration throughout the TL process and providing an environment that encourages the creative process.

These findings are in line with the Sarifuddin & Ahmad (2023), Xue et al., (2023) and Vilarinho-Pereira et al., (2021) which is Implementing TL refers to how teachers apply knowledge, intelligence creatively and practically as well as diverse thinking styles to take advantage of new, innovative teaching approaches or strategies as well as use imagination in delivering subject content. In addition, when implementing TL, teachers' creativity is required by taking into account the development of students' skills, including the ability to relate knowledge freely and logically based on creative thinking. In this regard, collaborative teaching is also seen as an approach that has proven effective to make a teacher more creative in producing something planned (Alzen et al., 2022). Therefore, by practicing creativity while implementing TL, teachers can also adjust their teaching approach based on their needs, interests and learning styles to be more effective. This statement is also supported by Ahmad & Azman (2020) and Md Mokhtar & Sahat (2022) which states that teachers who practice creativity while implementing TL can improve their expertise and teaching quality. In this regard, the effectiveness of practicing creativity in teaching can also improve the student experience through more meaningful learning. These findings are consistent with Sternberg's theory of creativity, which underlines that teachers' creativity is an important cognitive process that takes place in their creative minds taking into account their knowledge, abilities and competence to act spontaneously in a fast time.

Conclusion and Recommendations

In conclusion, these findings provide valuable insights with the adaptation of Sternberg's theory of creativity as a key backing to the development of the Framework that forms an CPT-ED Implementing TL. In line with these findings, Sternberg's theory of creativity practice clearly shows that creativity in teacher teaching is not a solitary trait but a multifaceted process formed as a result of the interaction of cognitive, emotional and contextual factors towards the effectiveness of the learning process. The implications of these findings show that the focus on teachers' ability to think flexibly, prioritise emotional intelligence, understand and appreciate the factors or situations that occur around them can create a supportive environment and foster creativity ultimately contributing to more effective and innovative teaching. This study can also have significant implications for ED teachers in SMT who also play an important role in ensuring the success of students. Through CPT-ED, the implementation of TL can be more effective and provide a more meaningful learning experience to students. Therefore, it is proposed that other further studies related to teachers' creative teaching practices to develop students' creativity can also be implemented as a reciprocity to identify the constructs, sub-constructs and elements of teachers' teaching practices towards students' creative learning.

References

- Abdul Aziz, A., Masodi, M. S., & Zaharim, A. (2013). *Asas Model Pengukuran Rasch: Pembentukan Skala Struktur Pengukuran Aziz*. Universiti Kebangsaan Malaysia.
- Abu, N. E., & Eu, L. K. (2014). Hubungan Antara Sikap, minat, pengajaran guru dan pengaruh rakan sebaya terhadap pencapaian matematik tambahan Tingkatan 4. *Jurnal Kurikulum & Pengajaran Asia Pasifik*, 2(1), 1–10. <https://doi.org/10.1140/epjc/s10052-012-2241-5>
- Abu Samah, N. A. B., Surat, S., & Rahman, S. (2022). Penglibatan Aktiviti Kokurikulum dan Kemahiran Insaniah dalam Kalangan Murid Sekolah Rendah. *Malaysian Journal of Social Sciences and Humanities (MJSSH)*, 7(4), 1–12. <https://doi.org/10.47405/mjssh.v7i4.1451>
- Afenu, D., Tsitsia, B., Kabbah, S., Attigah, A., & Bimpeh, G. (2021). Effective Time Management Practices Among Colleges of Education Students. *Journal of Human Resource and Leadership*, 6(1), 1–10. <https://doi.org/10.47604/jhrl.1245>
- Afriandani, A., Wahyuddin, & Nursakiah. (2019). Analisis Kesalahan Siswa Dalam Menyelesaikan Soal Cerita Matematika Berdasarkan Prosedur Newman. *Lentera Sriwijaya : Jurnal Ilmiah Pendidikan Matematika*, 1(2), 1–12. <https://doi.org/10.36706/jls.v1i2.9707>
- Ahmad, A., & Jingga, N. (2015). Pengaruh kompetensi kemahiran guru dalam pengajaran terhadap pencapaian akademik pelajar dalam mata pelajaran Sejarah. *Jurnal Kurikulum & Pengajaran Asia Pasifik*, 3(2), 1–11.
- Ahmad, N. L., & Azman, N. A. H. (2020). Tahap Amalan Pengajaran Berkesan Guru Prinsip Perakaunan Berasaskan Model Slavin. *Jurnal Pendidikan Malaysia*, 45(01), 53–62. <https://doi.org/10.17576/JPEN-2020-45.01-06>
- Alzen, J. L., Trumble, I. M., Cho, K. J., & Vance, E. A. (2022). *Training Interdisciplinary Statistical Collaborators : A Comparative Case Study*. 1–22. <https://doi.org/https://doi.org/10.21203/rs.3.rs-1831444/v1>
- Amatan, M. A., & Han, C. G. K. (2019). the Influence of School'S Psychosocial Environment and the Teacher'S Self-Efficacy on the 21st Century Teaching and Learning Practices. *International Journal of Education, Psychology and Counseling*, 4(32), 284–314. <https://doi.org/10.35631/ijepc.4320026>
- Andila, K., Yuliani, H., & Syar, N. I. (2021). Pengembangan Bahan Ajar Fisika Berbentuk E-Modul Berbasis Kontekstual Menggunakan Aplikasi eXe-Learning Pada Materi Usaha dan Energi. *Kappa Journal*, 5(1), 68–79. <https://doi.org/10.29408/kpj.v5i1.2757>
- Awang, Z. (2015). *SEM Made Simple: A Gentle Approach Structural Equation Modeling*. MPWS Rich Publication.
- Batjo, N., & Ambotang, A. S. (2019). Pengaruh Pengajaran Guru Terhadap Kualiti Pengajaran Guru. *Malaysian Journal of Social Sciences and Humanities (MJSSH)*, 4(2), 30–42.
- Brauer, R., Ormiston, J., & Beusaert, S. (2024). Creativity-Fostering Teacher Behaviors in Higher Education : A Transdisciplinary Systematic Literature Review. *Review of Educational Research*, 0(0), 1–30. <https://doi.org/10.3102/00346543241258226>
- Brouwers, S., & Vijver, F. J. . (2015). Contextualizing intelligence in assessment: the next step. Human. *Human Resource Management Review*, 25(1), 38–46. <https://doi.org/doi.org/10.1016/j.hrmr.2014.09.006>
- Cao, S., Li, H., Wu, Z., Liu, H., & Yang, M. (2021). Application of Project-Driven Teaching in College English Class. *International Journal of Emerging Technologies in Learning*, 16(21), 149–162. <https://doi.org/10.3991/ijet.v16i21.26869>

- Castro, A. J. (2010). Themes in the research on preservice teachers' views of cultural diversity: Implications for researching millennial preservice teachers. *Educational Researcher*, 39(3), 198–210. <https://doi.org/10.3102/0013189X10363819>
- Claessens, B. J. C., Eerde, W. Van, Rutte, C. G., & Roe, R. A. (2007). A review of the time management literature. *Personnel Review*, 36(2), 255–276. <https://doi.org/10.1108/00483480710726136>
- Corazza, G. E., Reiter-Palmon, R., Beghetto, R. A., & Lubart, T. (2021). Intelligence and creativity in the space-time continuum for education, business, and development. *Journal of Creativity*, 31, 1–6. <https://doi.org/10.1016/j.yjoc.2021.100003>
- Dagang, M. Y. (2016). *Amalan Kreativiti Pengajaran Guru Pendidikan Islam Di Sekolah Negeri Johor*. Universiti Tun Hussein Onn Malaysia.
- Daly, S. R., Mosyjowski, E. A., & Seifert, C. M. (2014). Teaching creativity in engineering courses. *Journal of Engineering Education*, 103(3), 417–449. <https://doi.org/10.1002/jee.20048>
- Dare, E. A., Keratithamkul, K., Hiwatig, B. M., & Li, F. (2021). Beyond content: The role of stem disciplines, real-world problems, 21st century skills, and stem careers within science teachers' conceptions of integrated stem education. *Education Sciences*, 11(11), 1–22. <https://doi.org/10.3390/educsci11110737>
- Eng Ling, O., & Kutty, F. M. (2022). Peranan Efikasi Kendiri dan Kemahiran Teknologi Digital Guru Sekolah Rendah dalam Memotivasikan Pembelajaran Murid. *Malaysian Journal of Social Sciences and Humanities (MJSSH)*, 7(3). <https://doi.org/10.47405/mjssh.v7i3.1374>
- Etikan, I., & Bala, K. (2017). Sampling and Sampling Methods. *Biometrics & Biostatistics International Journal*, 5(6), 215–217. <https://doi.org/10.15406/bbij.2017.05.00149>
- Fischer, S., & Barabasch, A. (2023). Conceptualizations and implementation of creativity in higher vocational teacher education – a qualitative study of lecturers. *Empirical Research in Vocational Education and Training*, 15(1). <https://doi.org/10.1186/s40461-023-00144-y>
- Fricker Jr, R. D. (2012). Sampling Methods for Web and email survey. In *The SAGE Handbook of Online Research Methods*. The SAGE Handbook of Online Research Methods. <https://doi.org/https://doi.org/10.4135/9780857020055.n11>
- Gralewski, J., & Karwowski, M. (2018). Are Teachers' Implicit Theories of Creativity Related to the Recognition of Their Students' Creativity? *Journal of Creative Behavior*, 52(2), 156–167. <https://doi.org/doi.org/10.1002/jocb.140>Citations: 54
- Hair, J. F., Black, W. C., Babin, B. J., & Anderson, R. E. (2014). *Multivariate Data Analysis*. (Seventh). Pearson Educational Limited. <https://doi.org/10.2307/2007941>
- Hamdan, N., Mei Heong, Y., Jailani, A., Masran, S. H., Boon Ching, K., Tze Kiong, T., & Mohamad, M. M. (2021). Penggunaan Gaya Berfikir Dan Kemahiran Berfikir Aras Tinggi Bagi Menyelesaikan Masalah Dalam Penghasilan Produk: Analisis Keperluan. *Sains Insani*, 6(2). <https://doi.org/10.33102/sainsinsani.vol6no2.311>
- Khanam, N., Sahu, T., Rao, E. V., Kar, S. K., & Quazi, S. Z. (2017). A study on university student's time management and academic achievement. *International Journal Of Community Medicine And Public Health*, 4(12), 4761–4765. <https://doi.org/10.18203/2394-6040.ijcmph20175365>
- Kimpa, V. A., & Salamuddin, N. B. (2022). Hubungan Antara Penglibatan Sukan dan Akademik Atlet Sekolah Rendah. *Malaysian Journal of Social Sciences and Humanities (MJSSH)*, 7(3), 1–13. <https://doi.org/10.47405/mjssh.v7i3.1385>

- King, D. T., & Ritchie, S. M. (2013). Academic Success in Context-Based Chemistry: Demonstrating fluid transitions between concepts and context. *International Journal of Science Education*, 35(7), 1159–1182. <https://doi.org/10.1080/09500693.2013.774508>
- Kit, C. S., & Mahmud, M. S. (2023). Keberkesanan Pembelajaran Berasaskan Perisian Terhadap Penguasaan Geometri dalam kalangan Murid Tahun Enam : Sebuah Tinjauan Literatur (Effectiveness of Software-Based Learning in Mastery Geometry among Year Six Students : A Literature Review). *Malaysian Journal of Social Sciences and Humanities (MJSSH)*, 8(1), 1–9. <https://doi.org/https://doi.org/10.47405/mjssh.v8i1.2037>
- Liu, C., & Elms, P. (2019). Animating student engagement: The impacts of cartoon instructional videos on learning experience. *Research in Learning Technology*, 27(1063519), 1–31. <https://doi.org/10.25304/rlt.v27.2124>
- Maarof, N. H., Joli, N. S., Apfandi, N., Md Zain, N. S., & Yusof, R. (2022). Persepsi Pelajar Pintar dan Berbakat Terhadap Penggunaan Filem dalam Pembelajaran dan Pemudahcaraan (PdPc) Subjek Sejarah. *Malaysian Journal of Social Sciences and Humanities (MJSSH)*, 7(10), 1–14. <https://doi.org/10.47405/mjssh.v7i10.1818>
- Madzalan, J., Ilias, M. F., Mohd Pisol, M. I., Jamar, A., & Basir, H. (2022). Tahap Kesediaan Guru Dalam Pelaksanaan Pengajaran Salah Sebuah Sekolah Kelolaan Yayasan Pendidikan Islam Selangor (YAPIS). *Malaysian Online Journal of Education*, 6(2), 11–18.
- Mahlianurrahman, M., & Aprilia, R. (2022). Lokakarya Pengembangan Media Pembelajaran Video berbasis Kearifan Lokal pada Kurikulum Merdeka. *Bubungan Tinggi: Jurnal Pengabdian Masyarakat*, 4(4), 1377–1384. <https://doi.org/10.20527/btjpm.v4i4.6119>
- Md Mokhtar, M., & Sahat, M. N. (2022). Tinjauan Berkaitan Amalan Kreativiti Guru Pendidikan Islam dalam Pengajaran dan Pembelajaran Abad ke-21 [Overview on The Creativity Practice of Islamic Education Teachers in Teaching and 21st Century Learning]. *BITARA International Journal of Civilizational Studies and Human Sciences*, 5(2), 1–10. <http://www.bitarajournal.com>
- Mohamed Mokhtar, M., Yaakub, R., & Amzah, F. (2018). Cabaran Guru Bahasa Melayu Dalam Usaha Menerapkan Kemahiran Berfikir Aras Tinggi (KBAT) Dalam Pembelajaran dan Pemudahcaraan (PDPC) Penulisan Karangan Argumentatif. *Attarbawiy: Malaysian Online Journal of Education*, 2(2), 7–14. <https://doi.org/10.53840/attarbawiy.v2i2.72>
- Mustaffa, Z., Hussin, Z., & Sulaiman, A. M. (2021). Pedagogi Terbeza Untuk Pengajaran Guru Terhadap Kepelbagaian Murid. *Malaysian Journal of Social Sciences and Humanities (MJSSH)*, 6(9), 202–214. <https://doi.org/DOL:https://doi.org/10.47405/mjssh.v6i9.997>
- Neuman, W. L. (2011). *Social Research Methods: Qualitative and Quantitative Approaches*. Allyn and Bacon.
- Ngatiman, S. (2018). *Konstruk Amalan Kreativiti Pengajaran Guru Lukisan Kejuruteraan*. Tesis Sarjana. Universiti Teknologi Malaysia.
- Ngatiman, S., & Saud, M. S. (2022). Kajian Awalan Tahap Amalan Kreativiti Pengajaran Guru Lukisan Kejuruteraan. In I. P. G. K. D. Aman (Ed.), *Prosiding SeDAR 2022* (pp. 394–413). Institut Pendidikan Guru Kampus Darulaman.
- Nor Pazilah, F., Hashim, H., & Yunus, M. M. (2014). Service-learning in English as a Second Language Teacher Training Program: Exploring Pre- service Teachers' Authentic Learning Experiences. *Paper Knowledge . Toward a Media History of Documents*, 12, 377–398. <https://doi.org/https://dx.doi.org/10.24093/awej/vol12no2.26>
- Patfield, S., Gore, J., Prieto, E., Fray, L., & Sincok, K. (2022). Towards quality teaching in higher education : pedagogy-focused academic development for enhancing practice. *International Journal for Academic Development*, 00(00), 1–16.

- <https://doi.org/10.1080/1360144X.2022.2103561>
- Putri, C. D., Pursitasari, I. D., & Rubini, B. (2020). Problem Based Learning Terintegrasi STEM Di Era Pandemi Covid-19 Untuk Meningkatkan Keterampilan Berpikir Kritis Siswa. *Jurnal IPA & Pembelajaran IPA*, 4(2), 193–204. <https://doi.org/10.24815/jipi.v4i2.17859>
- Rrustemi, J., & Sylaj, V. (2022). Exploring the Facilitation of the Student Learning Process Through Dominant Teaching Techniques. *International Journal of Learning, Teaching and Educational Research*, 21(11), 409–425. <https://doi.org/10.26803/ijlter.21.11.23>
- Rushdi, N. M., & Amran, M. S. (2020). Kreativiti Dalam Proses Pengajaran dan Pembelajaran. *Persidangan Antarabangsa Sains Sosial Dan Kemanusiaan Ke-5 (PASAK5 2020)*, 322–332.
- Sahrir, M. S., Osman, N., & Muhammad, I. S. (2020). Aplikasi “Konsep 4C” Pembelajaran Abad ke-21 dalam Kalangan Guru Pelajar Sarjana Mod Pengajian Pendidikan Bahasa Arab Cuti Sekolah UIAM. *E-Jurnal Bahasa Dan Linguistik*, 2(1), 12–22. <http://ejbl.kuis.edu.my>
- Samsudin, M. Z., Hassan, R., Hasan, A., & Shamsuddin, M. A. D. (2013). Amalan kreativiti guru dalam Pengajaran Pendidikan Asas Vokasional (PAV). *Technology, Education and Science International Conference (TESIC), October 2014*, 1–11. <https://doi.org/10.13140/2.1.4265.2161>
- Sanuddin, N. D., & Hashim, A. (2018). Pembinaan program spark dalam kalangan kanak-kanak berumur 11 tahun: Kajian rintis. *Jurnal Sains Sukan & Pendidikan Jasmani*, 7(1), 46–52. <https://doi.org/10.37134/jsspj.vol7.1.5.2018>
- Sarifuddin, N., & Ahmad, A. (2023). Keberkesanan Pembelajaran Koperatif Menggunakan Kaedah Jigsaw II dalam Penulisan Esei Sejarah. *Malaysian Journal of Social Sciences and Humanities (MJSSH)*, 8(1), 2504–8564. <https://doi.org/10.47405/mjssh.v8i1.2030>
- Seng, O. J., & Othman, S. (2018). Tahap Pengetahuan dan sikap Guru terhadap pendekatan didik hiburan dalam pengajaran Bahasa Melayu. *International Journal of Education and Training*, 4(2), 1–9.
- Shalihat, L. S., Lili Nanih, S. Y., & Alamsyah, U. S. (2022). Creative Character Training (CCT): Dampaknya terhadap Karakter Kreatif Guru Pendidikan Anak Usia Dini. *Jurnal Obsesi : Jurnal Pendidikan Anak Usia Dini*, 6(2), 565–578. <https://doi.org/10.31004/obsesi.v6i2.1352>
- Sherpa, D. (2020). Diversity Management in Classroom: Exploration of Teacher’s Role. *Patan Pragma*, 7(1), 279–288. <https://doi.org/10.3126/pragma.v7i1.35253>
- Strean, W. B. (2011). Evolving Toward Laughter in Learning. *Collected Essays on Learning and Teaching*, 1, 75–79. <https://doi.org/10.22329/celt.v1i0.3182>
- Timbang, M., & Ambotang, A. S. (2020). Pengaruh Inovasi Teknologi, Peranan Pentadbir dan Kediaan Guru Terhadap Profesionalisme Keguruan Sekolah Luar Bandar di Sabah. *Malaysian Journal of Social Sciences and Humanities (MJSSH)*, 5(2), 96–106. <https://doi.org/10.47405/mjssh.v5i2.369>
- Tunnisa, D., Mahmud, M., & Salija, K. (2019). Investigating teacher’s sense of humor in Indonesia. *International Journal of Language Education*, 3(2), 99–114. <https://doi.org/10.26858/ijole.v3i2.10201>
- Uzunboylu, H. (2019). Editorial Article Sidebar. *New Trends and Issues Proceedings on Humanities and Social Sciences*, 6(5), 1–4. <https://doi.org/https://doi.org/10.18844/prosoc.v6i5.4381>
- Vakil, S., Byrd, D., & Atkinson Smolen, L. (2023). Making Connections with Parents of English Learners: Promoting Culturally and Linguistically Diverse Classrooms. *Journal of the International Society for Teacher Education*, 27(1), 5–14.

<https://doi.org/10.26522/jiste.v27i1.4231>

- Vilarinho-Pereira, D. R., Koehler, A. A., & De Souza Fleith, D. (2021). Understanding the Use of Social Media to Foster Student Creativity: A Systematic Literature Review. *Creativity*, 8(1), 124–147. <https://doi.org/10.2478/ctra-2021-0009>
- Vinathan, T. A. P. (2016). Hubungan Motivasi Guru Dengan Penggunaan ICT Dalam Pengajaran di SJK (T) Daerah Kuala Muda Yan. *International Seminar on Generating Knowledge Through Research, UUM-UMSIDA*, 1, 1043–1054. <https://doi.org/http://dx.doi.org/10.21070/piccrs.v1i1.647>
- Xhomara, V., & Uka, A. (2022). Creativity in Education : Fostering Creativity in the Classroom Using Creative Teaching Methods. *Beder Journal of Educational Sciences*, 26(2), 1–21. <https://doi.org/10.5281/zenodo.8068813>
- Xue, Y., Mu, H., Xue, L., & Wang, X. (2023). Teaching Innovation and Practice of Mind Mapping Applied to Engineering Drawing Course. *2023 IEEE 12th International Conference on Educational and Information Technology, ICEIT 2023*, 156–161. <https://doi.org/10.1109/ICEIT57125.2023.10107785>
- Yağan, F., & Kaya, Z. (2022). Cognitive flexibility and psychological hardiness: examining the mediating role of positive humor styles and happiness in teachers. *Current Psychology*, 42(34), 29943–29954. <https://doi.org/https://doi.org/10.1007/s12144-022-04024-8>
- Yasin, R., Mustapha, R., Minghat, A. D., Jusoff, K., Ishar, A., & Shamsudin, S. (2012). Pelaksanaan Pengajaran dan Pembelajaran Mata Pelajaran Lukisan Kejuruteraan di Sekolah Menengah. *Asia Pacific Journal of Educators and Education*, 27, 23–36. [https://doi.org/10.1016/0304-3835\(85\)90058-8](https://doi.org/10.1016/0304-3835(85)90058-8)
- Yusuf, M., Rahmawati, Akmal, Daulay, E., & Lubis, A. A. (2021). Using Humor in Virtual Classroom: Lecturer’s Pers. *Talenta Conference Series: Local Wisdom, Social, and Arts (LWSA)*, 4(2), 92–99. <https://doi.org/10.32734/lwsa.v4i2.1197>