

# Informal Social Control Impact on Young People Political Participation Integrity: Structural Equation Modelling Approach

Mohd Sufiean Hassan, Siti Nurshahidah Sah Allam, Noor  
Afzaliza Nazira Ibrahim

Faculty of Communication and Media Studies, Universiti Teknologi MARA (UiTM), Melaka,  
78000 Alor Gajah, Malaysia

Maizatul Haizan Mahbob

Centre for Research in Media and Communication, Universiti Kebangsaan Malaysia

Rizky Hafiz Chaniago

Faculty of Economics & Social Sciences, Universitas Bakrie, Indonesia

**To Link this Article:** <http://dx.doi.org/10.6007/IJARBSS/v12-i4/12909> DOI:10.6007/IJARBSS/v12-i4/12909

**Published Date:** 03 April 2022

## Abstract

Innovation of communication technology, especially social media offer an interactive platform for young people to participate in political activities. Lack of informal social control reported by social scientists has a significant influence on low integrity political activities such as flashing provocation, joining the street demonstration, spreading fake news, defamation, and slanders with intentionally to create damage on certain political parties. This study aims to examine the factors that determine the integrity of political participation among young people using a theoretical model based on the Informal Social Control Theory. Data relating to the constructs were collected from 388 respondents in Malaysia and subjected to Structural Equation Modelling analysis. The proposed model fits the data well. Results indicate that the important determinant of the young people's political participation integrity is involvement. The rest three dimensions namely attachment, belief, and commitment are insignificant influences on the young people's political participation integrity. Perhaps with literacy skills able to shape young people with integrity in political participation on social media. Finally, implications and recommendations of these findings are discussed.

**Keywords:** Informal Social Control, Involvement, Political Participation Integrity, Young People, Social Media.

**Introduction**

The issues of young people political participation integrity are reported to have impacted aggressive action among rally supporters (Auvinen, 2012) where the use of social media to disseminate information among the participants of the demonstration events gathering, dissemination or seditious libel that could eventually lead to the country vulnerable to external attacks and threats (Al-Kandari & Hasanen, 2012; Azizuddin et al., 2010; Razid, 2014).

This scenario reveals that the political participation of young people in social media without following the guidelines directly affects the integrity (Anon, 2015). The actions of young people without integrity as sharing inaccurate information (Harper, 2017), give negative comments (Samuel-Azran et al., 2017), causing chaos to gain popularity or viral (Edgerly et al., 2016) and eventually will lead to cybercrime (Razid, 2014). Therefore, this study argues that to prevent and strengthen the young people political participation integrity, informal social control is expected to produce the idea of strengthening the implementation of the young people political participation integrity.

Young people often associated with acts of aggression and receptive to the expansion of technology (Fatimah & Ali, 2015). This group also is the agent of national transformation, whose guides the country toward global aspirations (Bahtiar, 2018). To drive national transformation in line with religious and cultural values, the execution of young people's integrity values can directly generate ethical leaders and reduce the tendency for immoral acts in the country's political system. Social control have been discussed as a control of human behaviour to curb immoral acts such as spreading false news, disseminating demonstration activity information among rally attendees, spreading slander or sedition that could eventually expose the country to external attacks and threats. (Al-Kandari & Hasanen, 2012; Razid, 2014; Norhawa, 2015).

**Problem Statement**

Within the framework of this study, social control considered as a special agent to channel or shaping young people with integrity behavioural that can be used as an opportunity to curb problems that Malaysia facing especially in terms of the belief dimension. Thus, the purpose of this study is to analyse to what extent the dimensions of social control influence the integrity of young people's political participation.

**Social Control Theory**

Social control theory believes that criminal misconduct can be overcome through two methods, namely: 1) formal social control such as laws and regulations, 2) informal social controls such as values, morals and ethics (Alston et al., 1995; Jeffrey et al., 2015). The social control theory began in 1951 by Albert J. Reiss and various constructs were tested to evaluate the effectiveness of social control in reinforcing the behaviour of non-integrity of young people. (e.g., Hirschi, 1969; Nye, 1958; Reckless, 1961; Toby, 1957). Hirschi (1969) was the main focus because he measures the role of social institutions such as family, society and friends to curb the misconduct of the young people. In addition, he also incorporates dimensions of informal social control such as attachment, belief, involvement, and commitment as the methods of measuring the effectiveness of informal social controls (Jiang et al., 2010).

Informal social control is the best method to curb the acts of non-integrity among the young people because this method is guided by values, moral and ethics that is applied to culture (Hirschi, 1969; Özden & Özcan, 2006). Hence, in measuring the effectiveness of this method, dimensions of informal social control such as attachment, belief, involvement, and commitment are examined (Eric & Miller, 2004). In addition, the effectiveness of informal social control also depends on the role of social institutions such as families, friends, universities and communities (Eric & Miller, 2004; Warner, 2014) .

The fundamental of the social control theoretical idea by Albert J. Reiss (1951) where as individual misconduct is contained through the function of an individual attachment to himself and the primary group and named as self-control and primary group control. Self-control refers to how someone refrain from its behaviour that is contrary to the norms and regulations of society (Brownfield, 2010). An individual with high self-control is the result of high social control relationships (Cohen & Zeira, 1999; Intravia, 2009).

In addition to self-control and behaviour of the primary group, the theory by Francis Ivan Nye (1958) is complemented by the belief of reward and punishment functions, in which he divides the elements of individual behaviour control into three (3), namely: 1) direct control, 2) indirect controls and 3) internal controls. Direct control refers to the belief of behaviours that are contrary to the values, norms and morals of the society committed by individuals will be punished and good behaviour, that compliance is rewarded by primary groups such as family, schools and communities.

Besides families, social institutions like universities and colleagues contribute to control individual behaviour, where the degree of involvement of individuals towards these social institutions is expected to affect the level of misconduct (Barfield-Cottledge, 2015). According to Toby (1957), the higher the involvement of individual life with the social institution, the lower the tendency of the young people to act non-integrity.

In addition to rewards and penalties, values, norms and morals are expected to curb individual misconduct, and according to Francis Ivan Nye (1958) it is named as indirect control. To refer how to refrain individual behaviour from committing wrongdoing, Ivan Nye described it as an internal control, in which the individual himself eschewed himself from committing misconduct on family's importance factor in society.

Besides the belief that human behaviour affects rewards and penalties, the theory of social control also believes that individual and primary groups' commitment to curbing acts of misconduct by individuals is a key factor. The original idea of containment theory was brought by Walter Reckless (1961) stating that individual and community commitment to curbing criminal behaviour is a major factor in which these symptoms should be contained before they occur, with the "*Compliance Stake*" or "*Stake in Conformity*" philosophy. Hence, Reckless divides social control into inner containment and outer containment, where inner containment refers to self-concept as an insulator or barrier to misconduct.

However, Hirschi (1969) combined four elements in the Social Bond / Social Control Theory discussed earlier, namely 1) attachment, 2) Belief, 3) Involvement, 4) Commitment (Intravia, 2009). These four elements are expected to be the main factor in reducing the

immoral behaviour of young people and these elements are combined with three social institutions, namely 1) family, 2) educational institutions, and 3) friends.

### *Dimension of Attachment*

Attachment refers to individuals having a bond or relationship with parents, communities and societies as sociologists from the United States argue that criminals are those who are marginalized by parents, community, and society (Brownfield, 2010). Individual attachment to parents, community and society affects the level of sensitivity of accepting their opinion as a living referral by individuals (Zhang et al., 1996).

This study is also supported by Chen (2004) which examines the value of “bang-jiao” which is the community’s efforts to reintegrate offenders into the community. The findings of this study prove that when there is a criminal behaviour in the community, individuals are not directly brought to justice (police and courts). Individual attachment to family and society can control the crime rate through internal discussions and settlements (with family members or members of the community) as acts of rehabilitation and application of moral values are given directly to the offender, rather than bringing offenders to the courts leading up to the conviction of law.

Özlem, & Haydari (2011) in their study found that significant relationship between the attachment of the young to the family, the university and society, where the traditional value, respecting families, and universities as well as communities in the Middle East is expected to be a factor in restricting the actions of non-integrity of young people. However, the dimensions of this attachment are also influenced by demographic factors such as income and the level of family education.

Families that promote sharing ideas and emotions increase the level of engagement between young people and families. The family’s function in helping young people to solve problems, decide and share emotions is expected to reduce the tendency of young people to find out-of-home solutions, where this opens a space of inaction with non-integrity. However, this depends on the level of education and income of a family, where low parent education levels are reported (Ferris et al., 2013) causing them to spend more time working on family income (Dunifon et al., 2013).

According to Nik Yaacob & Siew (2010), mothers who work overtime became the factor of aggressive action of young people and the findings were also supported by Nik Rosila & Siew (2010) where working mothers had time constraints with children and have minimal time to monitor academic achievement and provide a negative experience throughout the growth of children. The impact of this negative experience led to the process of personality development and the young people’s character, mainly emotionally and spiritually (Han & Miller, 2009; Han et al., 2010; Lyons-Ruth, 1996).

Apart from the attachment to the family, the involvement of young people with the university is also expected to impact on non-integrity action (Wray-Lake et al., 2012), where young people’s confidence in these social institutions in solving problems, decision-making and sharing of emotions is a barrier to non-integrity of young people.

Young people's attachment to co-curricular activities at the university is reported could curb non-integrity behaviour of young people (Fingar & Jolls, 2014; Lawrence, 1985). This is because the attachment to co-curriculum activities is a platform for young people to have bond with university lecturers and administration, and also to care for personal performance and achievement of young people is expected not to engage in immoral activities (Farb & Matjasko, 2012). Thereby, we propose the following:

H1: Attachment will have a significant positive effect on the of young people Political Participation Integrity.

#### *Dimension of Belief*

For the element of belief, it refers to the level of compliance values, loyalty and individual beliefs of religious institutions and legislation (Alston et al., 1995). From past study, various fields of culture and religion believed that religion was able to curb the action of non-integrity of young people. Religious institutions are responsible for promoting values, morals and ethics for young people to become a community of integrity (Obasola, 2013).

Religious practices and volunteerism participate in religious activities among young people are expected to enhance moral values and integrity. According to Laird et al (2011) in the study of religious function in reinforcing non-integrity action found that more often young people participating in religious activities, higher values of integrity are nurtured. However, the lower participating in religious activities will bring the young people to be more likely to involve with misconduct activity.

The finding of this study was also supported by Ludden (2011) study on volunteerism among rural young peoples that young people participating in religious activities were reported to be more involved with volunteerism, lack of behavioural problems, high motivation and high academic achievement. In addition, these civic activities are not only participated in residential areas, but they will also participate in religious activities organized by the university.

The belief that religious institutions are not only able to improve the integrity of the young people, but this belief directly enhances their academic performance. This idea is supported by Mustapha (2013) who studies religion and non-integrity among young people found that respondents with high religious beliefs have a family background that emphasizes religious aspects within the family (Chamrathirong et al., 2013). In addition, young people that have embraced moral values and religious principles as the basis of life were found less likely to participate in activities without integrity. In addition to families, educational institutions with high religious spheres are reported to have high academic achievement (Farb & Matjasko, 2012). This clearly demonstrates the belief in religion not only reinforces non-integrity action, but also affects academic achievement and personal development of young people.

In addition to religious institutions, belief in laws and enforcement bodies' initiatives in curbing non-integrity action is also reported to increase the integrity of the young. The belief that every misconduct is confronted with the right punishment (Jiang et al., 2014) and joining volunteerism activities organized by enforcement bodies is expected to curb undermining young people (Weisburd & Eck, 2004).

The law was established to ensure stability and security within the community and law enforcement is to ensure that community groups comply (Justice & Prevention, 2018). Volunteer initiatives and activities implemented by an enforcement body aim to inject the awareness of young people to restrain themselves from non-integrity activities (Wiley & Esbensen, 2016). While informal social controls are expected to be more effective for the long term to curb non-integrity action, formal legal controls, especially law are indispensable because of its effectiveness in the short run to control non-integrity (Omoyibo & Obaro, 2012). In regard to the integrity of political participation of young people, we test the following hypothesis:

H3: Belief will have a significant positive effect on the young people Political Participation Integrity.

#### *Dimension of Involvement*

The dimension of involvement refers to individual involvement with social activities performed during leisure time. The main idea is that the higher individual involvement of social activity during leisure is expected to reduce the tendency of immoral activity (Wiatrowski et al., 1981). Someone involved in social activity will be bound by certain deadlines, dates, hours, and plans (Brownfield, 2010).

Family involvement in meeting free time with young people is expected to curb non-integrity action (Hoffmann, 1995). Interaction with family in social activities not only reinforces non-integrity action, but also has a positive impact on the development of personality and character of young people. This is because interactions between families and young people form a positive emotion that became the factor of neglect of immoral activity (Khoury-Kassabri et al., 2015).

However, family involvement in fulfilling leisure time with young people is closely related to the structure of family interaction. According to Hovee et al (2011), parents who have low interaction with young people because family structure failure is expected to also have low involvement to spend time on social activities. This directly contributes to the level of non-integrity of the young people (Dunifon et al., 2013).

In addition, social activities carried out with colleagues and universities are also reported to reduce the inclination of the young people to do non-integrity action (Ferris et al., 2013). This is because, in practice, participation in university clubs is associated with excellent academic achievement and the involvement of social activities like religiously linked to low non-integrity action (Ludden, 2011).

The involvement of social activities, especially with colleagues, is expected to open the opportunity for communication interaction and the space of non-integrity. According to Boyes et al. (2017) in his study of sports athletes, physical activity has directly opened the space of activity of young people with disabilities such as drug abuse. The use of drugs in physical activity is encouraged by friends who tend to have high sports performance but in the wrong way. The findings of this study were also supported by the previous study, in which the concerns of young people were denied by colleagues make this individual reject the value of integrity (Chapple, 2005).

However, involvement in social activities with colleagues at the university is capable in developing young people leadership, communication and social responsibility skills. Directly, this skill creates a better personality than young people who do not involve in social activities with colleagues and universities (Farb & Matjasko, 2012). Voluntary social activities especially involving voluntary organizations increase young people civic engagement initiatives. Time allocation in managing volunteering activities directly reduces the inclination of young people into non-integrity activities (Quintelier, 2008).

This study is supported by Oosterhoff et al (2017) reported that the period of social activity involving young people with colleagues and the university directly increased confidence and self-esteem, where the higher the involvement of young people in social activities, the higher the level of neglect of non-integrity.

This is due to the time set for carrying out social activities, namely planning and implementation of this activity that contributes to the integrity of the young (Peck et al., 2008). Involvement in the process of planning and implementation of social activities is reported to have a negative impact on non-integrity actions and to enhance the development of soft skills among young people (Ferris et al., 2013). Thus, it is hypothesized that:

H3: Involvement will have a significant positive effect on the young people Political Participation Integrity.

#### *Dimension of Commitment*

Commitment dimension which refers to the commitment of the young in preserving the emotions or feelings, views and perceptions of major affiliations, namely: 1) family, 2) educational institutions (school) and 3) friends against the effects of conduct (Baumeister & Leary, 1995). According to Wheeler et al (1983), the dimension of commitment is to maintain social bonds among young people with social institutions and is reported to reduce the inclination of non-integrity.

This is to maintain an individual's level of compliance with the key combination. Hirschi argues that the higher the level of individual emotional commitment with the key combination, the less individual tendency is to act unintegrated. The support of this argument is that human basic needs are security, where to be safe, no individual in the world wants to live alone and acts alone to induce stress (Han et al., 2010). The idea that life alone negatively affects young people is also linked to the findings of the study of Valdimarsdóttir, & Bernburg (2015) on the commitment of young people with social institutions and acts of non-integrity of young people. The results of the study report that young people's commitments to neighbourhood activities can have a negative impact on their level of non-integrity (Warner & Burchfield, 2011), where the lower levels of young people commitments with neighbourhood activities, the lower values of young people integrity (Thorlindsson et al., 2012).

The low level of integrity of young people is closely related to family commitment in applying religious, social and cultural values in young people who value the integrity of young people (Chamrathirong et al., 2013). Fostering the value of integrity of young people by the family, is reported to have a significant relationship between the commitment of the young

and the family (Schroeder et al., 2010). This study is consistent with previous literature that highlighted young people who have a high commitment to maintaining good relationships with their families such as being individual expectations and serving the family are expected to reduce the tendency of this individual to engage in uninspiring activities (Khoury-Kassabri et al., 2015).

In addition, emotional bonds that derive from the family to young people foster positive emotions, mental health and behaviour with integrity as opposed to young people who lack emotional support from the family. This idea is supported by the study of Chamratrithirong et al. (2013) suggests that parents' commitment to the younger generation is a significant predictor of the integrity act of young people and is largely due to the application of positive emotions. Hence, we posit that:

H4: Commitment will have a significant positive effect on the young people Political Participation Integrity.

All in all, the proposed research model is presented in Figure 1.

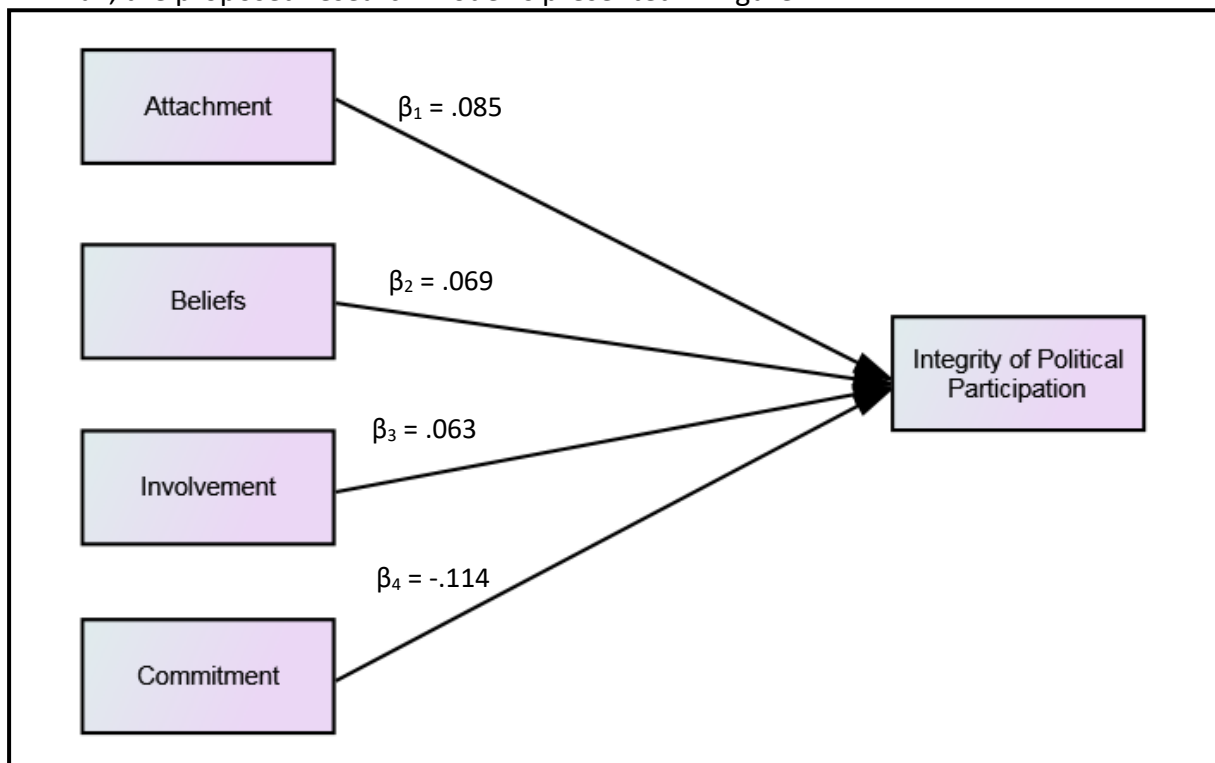

Figure 1 : Research model

### Methodology

Four hundred questionnaires were distributed to students simple random sampled at a higher learning institution in Melaka, Malaysia. 400 questionnaires were distributed, and 388 respondents replied, i.e., the response rate was 97%. It took a month to complete the data collection. The scale items for attachment, involvement were adapted from Byung Jun Cho (2014). However, considering the cultural aspects of Malaysia, this study considers the Dimensions of the beliefs not only in terms of law, but also in the aspect of religious beliefs. Therefore, in order to test the Dimensions of Belief in religious aspects, the instrument used is the Religious Scale by Abou-Youssef et al (2011). Hence, the items selected represent the



concepts in the empirical model under investigation and ensure the content validity of the scales. Appendix 1 shows the detailed constructs in the proposed model. The questionnaires were designed using a seven-point Likert scale ranging from 1 (strongly disagree) to 7 (strongly agree). Data were collected and analysed using structural equation modelling (SEM) supported by AMOS 21.0 with maximum likelihood estimation in order to test the proposed hypotheses. SEM is a second-generation multivariate technique that combines multiple regressions with confirmatory factor analysis to estimate simultaneously a series of interrelated dependence relationships. SEM is a widespread technique in several fields including marketing, psychology, social sciences and information systems (Byrne, 2016; Fornell & Larcker, 1981; Hair et al., 2014; Hoyle, 1995).

### Findings and Discussions

Table 1 summarizes the socio-demographic profile of the sample. There were 388 students who participated in the survey with 165 of them males and 223 females. 9.5 percent of the students, or 37 of them, are between the age of 18-20, 54.9 percent of the students, or 213 of them, are between 21-23, 22.7 percent of the students, or 88 of them, are between 24-26, 9.5 percent of the students, or 37 of them, are between 27-29, and the remaining 3.4 percent of the students, 13 of them, are aged between 30-40 years. The survey revealed that more than 85% of the respondents are married. Most of the respondents have been educated to college or higher education level: 2.6% are STPM, 3.6% are Matriculation, 2.6% are pre-diploma, and 59.8% diploma holders while 32% have bachelor's degrees. In addition, 49.2% of the respondents used social media more than ten times a day and 29.6% have used to update social media accounts 1-30 minutes once.

Table 1

*Demographic profile of respondents*

Profile	Frequency	Percentage (%)
<b>Gender</b>		
Male	165	42.5
Female	223	57.5
<b>Age</b>		
18-20	37	9.5
21-23	213	54.9
24-26	88	22.7
27-29	37	9.5
30-40	13	3.4
<b>Marital Status</b>		
Single	338	87.1
Married	38	9.8
Other	12	3.1
<b>Religion</b>		
Islam	290	74.7
Christian	39	10.1

Buddha	36	9.3
Hindu	17	4.4
Other	6	1.5
<b>Race</b>		
Malay	286	73.7
Chinese	66	17.0
Indian	19	4.9
Other	17	4.4
<b>Level of Education</b>		
STPM	10	2.6
Matriculation	14	3.6
Pre-Diploma	10	2.6
Diploma	232	59.8
Degree	124	32.0
<b>HEI</b>		
UiTM	136	35.1
UTeM	99	25.5
MMU	100	25.8
KUIM	53	13.7
<b>Frequency of using social media in a day?</b>		
1-2 times	24	6.2
3-5 times	80	20.6
6-10 times	93	24.0
> 10 times	191	49.2
<b>The time used to update social media accounts?</b>		
1-30 minutes	115	29.6
31 minutes -1 hour	98	25.3
1 hour- 2 hours	85	21.9
> 3 hours	90	23.2

### Reliability Analysis

Based on the Confirmatory Factor Analysis (CFA) results, we analysed convergent validity, discriminant validity, and reliability of all the multiple-item scales, following the guidelines from previous literature (Fornell & Larcker, 1981). The measurement properties are reported in Tables 2 and 3. Reliability was assessed in terms of composite reliability (CR), which measures the degree to which items are free from random error and therefore yield consistent results. Composite reliabilities in the measurement model ranged from 0.866 to 0.925 (see Table 2), above the recommended cut-off of 0.70 (Fornell & Larcker, 1981; Nunnally & Bernstein, 1994).

Table 2

*Reliability and Factor Loadings*

Construct / Measurement items	Standardized Loadings	CR	AVE
<b>Attachment</b>		0.798	0.570
AT1	.522		
AT2	.548		
AT3	.585		
AT4	.724		
AT5	.626		
AT6	.647		
<b>Beliefs</b>		0.833	0.558
BL1	.731		
BL2	.836		
BL3	.793		
BL4	.609		
<b>Involvement</b>		0.737	0.413
IN1	.601		
IN2	.657		
IN3	.628		
IN4	.681		
<b>Commitment</b>		0.878	0.592
CO1	.671		
CO2	.650		
CO3	.770		
CO4	.717		

Convergent validity was assessed in terms of factor loadings and average variance extracted (AVE). According to the prior study, convergent validity requires a factor loading greater than 0.50 and an AVE no less than 0.50. As shown in Table 2, all items had significant factor loadings higher than 0.50. To evaluate discriminant validity, the AVE is used. All constructs have an AVE of at least 0.5 (Fornell & Larcker, 1981) and all the square roots of each AVE value are higher than the off-diagonal correlation elements (Henseler, Ringle, & Sarstedt, 2015; Fornell & Larcker, 1981).

Table 3

*Correlation matrix and roots of the AVEs (shown as diagonal elements)*

	1	2	3	4	5
(1) Attachment	0.755				
(2) Belief	0.428	0.747			
(3) Involvement	0.349	0.590	0.643		
(4) Commitment	0.410	0.357	0.137	0.769	
(5) Political Participation Integrity	0.243	0.367	0.571	0.042	0.862
Mean	4.803	4.658	4.399	5.462	4.510
Std. Deviation	1.032	1.227	1.190	1.094	1.390

\*\* Correlation is significant at the 0.01 level (2-tailed).

Analysis of Paths

The test of structural model was performed using SEM. The test of the structural model includes: (a) estimating the path coefficients, which indicate the strengths of the relationships between the dependent variables and independent variables, and (b) the R-square value, which represents the amount of variance explained by the independent variables. The path coefficients in the SEM model represent standardized regression coefficients. The structural model reflecting the assumed linear, causal relationships among the constructs was tested with the data collected from the validated measures. Figure 2 shows the results of analysis. The square multiple correlation for the structural equations index indicates that 34% of the variation in the dependent variable is explained by the variation in the independent variables. Properties of the causal paths (standardized path coefficients ( $\beta$ ), standard error, p-value and hypotheses result) are shown in Table 4.

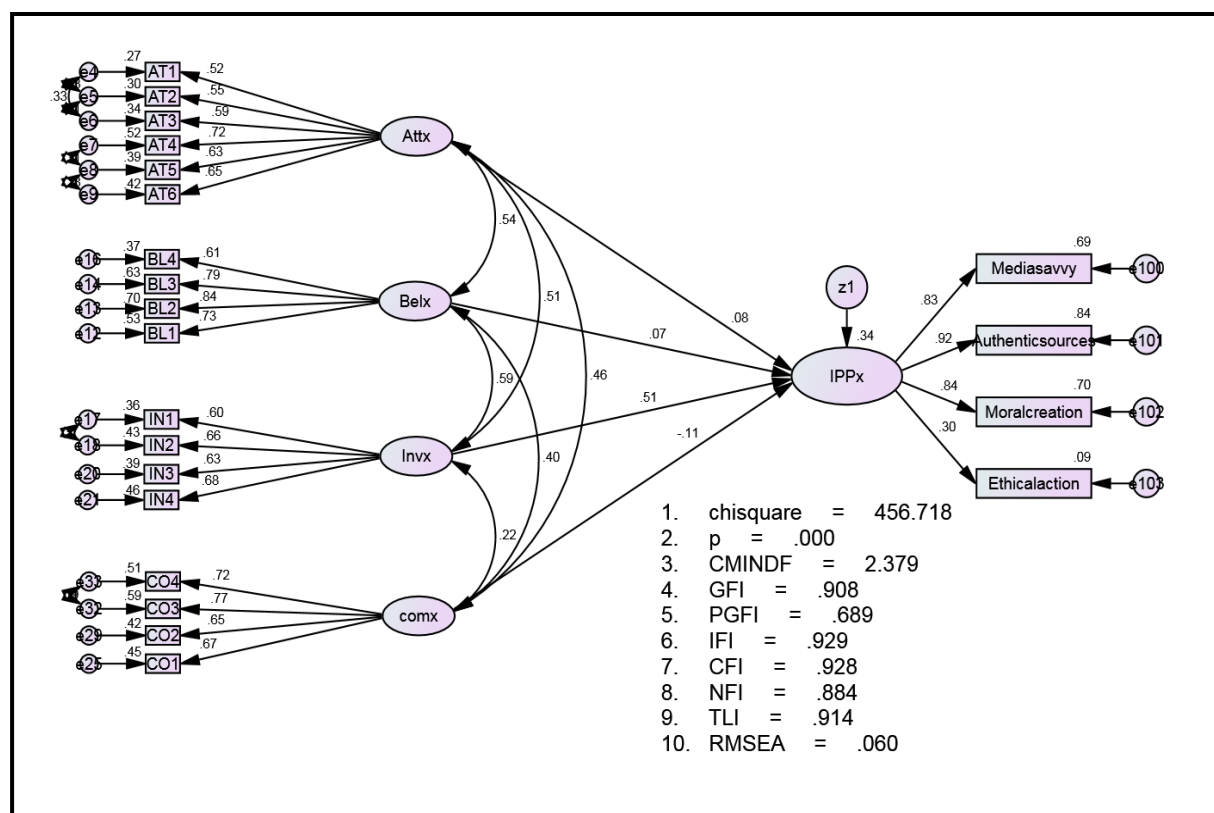

Figure 2 : Estimated research model

Young People Political Participation Integrity

The effect of Attachment on young people political participation integrity was insignificant at 0.05 level ( $\beta_1 = 0.085$ ), as presented in Table 4 and Figure 2. Thus, H1 was not supported. Attachment with family, university and friend would not improve young people integrity in political participation. With a good attachment with agent socialization does not make sure that young people will avoid from deviant behaviour and is not influences their political integrity. Beliefs had also insignificant influence on the young people political participation integrity ( $\beta_2 = 0.069$ ). Thus, H2 was not supported. As expected, Involvement had significant positive influence on political participation integrity at 0.05 level ( $\beta_3 = 0.063$ ), supporting H3 (refer to Table 4 and Figure 2). Involvement has significant positive effect on the political participation integrity predictors. As expected, young peoples that busy with involvement and

activities in university and community were more strongly affected their political participation integrity. Commitment had insignificant influence on Political Participation Integrity at 0.05 level ( $\beta_4 = -.114$ ), not supporting H4. In contrast with our expectation commitment of young people to family, friend and university does not affect them.

Table 4

*Result of hypotheses test*

	Path			$\beta$	S.E.	P	Result
H1	IPP	<---	Attx	.085	.880	.322	Not Supported
H2	IPP	<---	Belx	.069	.737	.396	Not Supported
H3	IPP	<---	Invx	.063	.898	***	Supported
H4	IPP	<---	Comx	-.114	.685	.091	Not Supported

Notes: Path = Relationship between independent variable on dependent variable;  $\beta$  = Standardized regression coefficient; S.E. = Standard error; p = Level of significance

### Implications and Conclusion

An empirical study was conducted to identify determinants of the young people political participation integrity in Malaysia. The aspect of involvement is the only factor that is significant to young people political participation integrity. Therefore, it can be concluded that social control alone is not able to increase young people's political participation integrity. The results demonstrated that the young people political participation integrity cannot be explained in terms attachment, beliefs, involvement, and commitment. There must be other variables that contribute to integrity behaviour. This finding opens a new area of discussion on the theory of social control that previous researchers have tested that finds that social control can counteract unethical behaviour (e.g., Hirschi, 1969; Intravia et al., 2011; Johns, 1999; Sufiean et al., 2018; Reiss, 1951). These findings also show that, despite having high social control, they are still unable to form good behaviours. This is because the freedom gained through social media with the exposure of various information and ideologies influences the way they think and act.

### Future Research

Future studies should be based on more than the four variables used here. Perhaps with media literacy skills able to shape young people with political participation integrity on social media This is because these four variables cannot fully explain the factors influencing the young people political participation integrity. Future researchers should also increase the sample size and ensure that their respondents constitute a balanced demographic. A longitudinal approach could also be employed to study the factors that determine the young people political participation integrity.

### Acknowledgement

This work was supported by Fundamental Research Grant Scheme (FRGS), Malaysia (FRGS/1/2020/SS0/KUIM/03/1).

## References

- Abou-Youssef, M., Kortam, W., Abou-Aish, E., & El-Bassiouny, N. (2011). Measuring islamic-driven buyer behavioral implications: A proposed market-minded religiosity scale. *Journal of American Science*, 7(8), 728–741.
- Al-Kandari, A., & Hasanen, M. (2012). The impact of the Internet on political attitudes in Kuwait and Egypt. *Telematics and Informatics*, 29(3), 245–253.
- Alston, R. J., Harley, D., & Lenhoff, K. (1995). Hirschi's social control theory: A sociological perspective on drug abuse among persons with disabilities. *The Journal of Rehabilitation Administration*, 61(4), 31–35.
- Anon. (2015). Effects of information and media literacy in social movements. *Online Arab Spring*, 1(1), 31–40.
- Auvinen, A. (2012). *Social Media - The new power of political Influence*. Suomen Toivo.
- Azizuddin, M. S., & Zengeni, K. T. (2010). Democratisation in Malaysia : the Impact of Social Media in the 2008 General Election. *18th Biennial Conference of the Asian Studies Association of Australia, October 2016*, 1–16.
- Bahtiar, M. (2018). Youth offline political participation: Trends and role of social media. *Jurnal Komunikasi*, 34(3), 192–207.
- Barfield-Cottledge, T. (2015). The Triangulation Effects of Family Structure and Attachment on Adolescent Substance Use. *Crime & Delinquency*, 61(2), 297–320.
- Baumeister, R. F., & Leary, M. R. (1995). The need to belong: desire for interpersonal attachments as a fundamental human motivation. *Psychological Bulletin*, 117(3), 497–529.
- Boyes, R., O'Sullivan, D. E., Linden, B., Mclsaac, M., & Pickett, W. (2017). Gender-specific associations between involvement in team sport culture and canadian adolescents' substance-use behavior. *SSM - Population Health*, 3(August), 663–673.
- Brownfield, D. (2010). Social control, self-control, and gang membership. *Journal of Gang Research*, 17(4), 1–12.
- Byrne, B. (2016). *Structural equation modeling with AMOS: Basic concepts, applications, and programming*. Routledge.
- Chamrathirong, A., Miller, B. A., Byrnes, H. F., Rhucharoenpornpanich, O., Cupp, P. K., Rosati, M. J., Fongkaew, W., Atwood, K. A., & Todd, M. (2013). Intergenerational transmission of religious beliefs and practices and the reduction of adolescent delinquency in urban Thailand. *Journal of Adolescence*, 36(1), 79–89.
- Chapple, C. L. (2005). Self-control, peer relations, and delinquency. *Justice Quarterly*, 22(1), 89–106.
- Chen, X. (2004). Social and legal control in China: a comparative perspective. *International Journal of Offender Therapy and Comparative Criminology*, 48(5), 523–536.
- Cho, B. J. (2014). Social bonds, self-control and deviance of Korean adolescents. *International Journal of Humanities and Social Science*, 4(9), 1–8.
- Cohen, B.-Z., & Zeira, R. (1999). Social Control, Delinquency, and Victimization among Kibbutz Adolescents. *International Journal of Offender Therapy and Comparative Criminology*, 43(4), 503–513.
- Dunifon, R., Kalil, A., Crosby, D. A., & Su, J. H. (2013). Mothers' night work and children's behavior problems. *Developmental Psychology*, 49(10), 1874–1885.
- Egerly, S., Thorson, K., Bighash, L., & Hannah, M. (2016). Posting about politics: Media as resources for political expression on Facebook. *Journal of Information Technology and Politics*, 13(2), 108–125.

- Eric, S., & Miller, L. L. (2004). Sources of informal social control in Chicago neighborhoods. *Criminology*, 42(3), 551–583.
- Farb, A. F., & Matjasko, J. L. (2012). Recent advances in research on school-based extracurricular activities and adolescent development. *Developmental Review*, 32(1), 1–48.
- Fatimah, A., & Ali, S. (2015). Partisipasi politik belia secara “online” melalui ruang demokrasi maklumat media baru. *Jurnal Komunikasi*, 31(1), 81–100.
- Ferris, K. A., Oosterhoff, B., & Metzger, A. (2013). Organized activity involvement among rural youth: Gender differences in associations between activity type and developmental outcomes. *Journal of Research in Rural Education*, 28(15), 1–16.
- Fingar, K. R., & Jolls, T. (2014). Evaluation of a school-based violence prevention media literacy curriculum. *Injury Prevention*, 20(3), 183–190.
- Fornell, C., & Larcker, D. F. (1981). Evaluating Structural Equation Models with Unobservable Variables and Measurement Error. *Journal of Marketing Research*, 18(1), 39.
- Hair, J. F., Black, W. C., Babin, B. J., & Anderson, R. E. (2014). *Multivariate Data Analysis*. Pearson Education Limited.
- Han, W. J., & Miller, D. P. (2009). Parental work schedules and adolescent depression. *Health Sociology Review*, 18(1), 36–49.
- Han, W. J., Miller, D. P., & Waldfogel, J. (2010). Parental work schedules and adolescent risky behaviors. *Developmental Psychology*, 46(5), 1245–1267.
- Harper, C. (2017). *Being more media savvy won't stop the spread of "fake news"-here's why*. The Conversation. <https://phys.org/news/2017-05-media-savvy-wont-fake-newshere.html>
- Henseler, J., Ringle, C. M., & Sarstedt, M. (2015). A new criterion for assessing discriminant validity in variance-based structural equation modeling. *Journal of the Academy of Marketing Science*, 43(1), 115–135.
- Hirschi, T. (1969). Key Idea : Hirschi ' S Social Bond / Social Control Theory. *Key Ideas in Criminology and Criminal Justice*, 1969, 55–69.
- Hoeve, M., Dubas, J. S., Gerris, J. R. M., Van Der Laan, P. H., & Smeenk, W. (2011). Maternal and paternal parenting styles: Unique and combined links to adolescent and early adult delinquency. *Journal of Adolescence*, 34(5), 813–827.
- Hoffmann, J. P. (1995). The effects of family structure and family relations on adolescent marijuana use. *The International Journal of the Addictions*, 30(10), 1207–1241.
- Hoyle, R. H. (1995). Structural equation modeling: Concepts, issues, and applications. In *Sage Publications, Inc.* Sage Publications, Inc.
- Intravia, J. (2009). The roles of social bonds, personality, and perceived costs: An empirical investigation into Hirschi's “new” control theory [University of South Florida]. In *Department of Criminology, College of Behavioral and Community Sciences*.
- Jiang, S., Lambert, E. G., Liu, J., & Saito, T. (2014). Formal and informal control views in China, Japan, and the U.S. *Journal of Criminal Justice*, 42(1), 36–44.
- Jiang, S., Wang, J., & Lambert, E. (2010). Correlates of informal social control in Guangzhou, China neighborhoods. *Journal of Criminal Justice*, 38(4), 460–469.
- Johns, J. (1999). *Controlling youth crime: a qualitative analysis of informal and formal social controls*. University of Windsor.
- Justice, J., & Prevention, D. (2018). *Interactions between youth and law enforcement*. January, 1–31.
- Khoury-Kassabri, M., Khoury, N., & Ali, R. (2015). Arab youth involvement in delinquency and

- political violence and parental control: The mediating role of religiosity. *American Journal of Orthopsychiatry*, 85(6), 576–585.
- Laird, R. D., Marks, L. D., & Marrero, M. D. (2011). Religiosity, self-control, and antisocial behavior: Religiosity as a promotive and protective factor. *Journal of Applied Developmental Psychology*, 32(2), 78–85.
- Lawrence, R. (1985). School performance, containment theory and delinquent behavior. *Youth and Society*, 17(1), 69.
- Ludden, A. B. (2011). Engagement in school and community civic activities among rural adolescents. *Journal of Youth and Adolescence*, 40(9), 1254–1270.
- Lyons-Ruth, K. (1996). Attachment relationships among children with aggressive behavior problems: The role of disorganized early attachment patterns. *Journal of Consulting and Clinical Psychology*, 64(1), 64–73.
- Sufiean, M. H., Haizan, M., & Helmi, M. A. R. (2018). Skala Psikometrik: Perspektif Kawalan Sosial Tidak Formal dan Pengukuhan Nilai Integriti Golongan Muda. *Jurnal Komunikasi: Malaysian Journal of Communication*, 34(4), 232–249.
- Mustapha, N. (2013). Religion and delinquency in Trinidad and Tobago. *International Journal of Social Science & Education*, 4(1), 135–152.
- Rosila, N. Y., & Siew, H. S. (2010). Mother working status and physical aggressive behavior among children in Malaysia. *Procedia - Social and Behavioral Sciences*, 5, 1061–1066.
- Nunnally, J. C., & Bernstein, I. H. (1994). *Psychometric theory (3rd ed.)*. McGraw-Hill.
- Nye, F. I. (1958). *Family relationships and delinquent behavior*. Wiley.
- Obasola, K. E. (2013). Religious imperatives as a panacea to crime and violence among youths in Nigeria. *European Journal of Business and Social Sciences*, 2(8), 112–122.
- Omoyibo, K. U., & Obaro, O. A. (2012). Applications of social control theory: Criminality and governmentality. *International Journal of Asian Social Science*, 2(7), 1023–1032.
- Oosterhoff, B., Kaplow, J. B., Wray-Lake, L., & Gallagher, K. (2017). Activity-specific pathways among duration of organized activity involvement, social support, and adolescent well-being: Findings from a nationally representative sample. *Journal of Adolescence*, 60, 83–93.
- Özden, Ö., & Özcan, Y. Z. (2006). A Test of Hirschi's Social Bonding Theory Juvenile Delinquency in the High Schools of Ankara, Turkey. *International Journal of Offender Therapy and Comparative Criminology*, 50(6), 711–726.
- Özlem, O., & Haydari, N. (2011). The state of media literacy in Turkey. *Procedia Social and Behavioral Sciences*, 15, 2827–2831.
- Peck, S. C., Roeser, R. W., Zarrett, N., & Eccles, J. S. (2008). Exploring the roles of extracurricular activity quantity and quality in the educational resilience of vulnerable adolescents: Variable- and pattern-centered approaches. *Journal of Social Issues*, 64(1), 135–156.
- Quintelier, E. (2008). Who is politically active : The athlete, the scout member or the environmental activist? *Acta Sociologica*, 51(4), 355–370.
- Razid, M. A. A. (2014). Jenayah siber isu mencabar. *Mentari*, 8–9. [www.penerangan.gov.my](http://www.penerangan.gov.my)
- Reckless, W. C. (1961). A new theory of delinquency and crime. *Federal Probation*, 25, 42–46.
- Reiss, A. J. (1951). Delinquency As the Failure of Personal and Social Controls. *American Sociological Review*, 16(2), 196–207.
- Samuel-Azran, T., Yarchi, M., & Wolfsfeld, G. (2017). Engagement and Likeability of Negative Messages on Facebook during Israel's 2013 Elections. *The Journal of Social Media in Society*, 6(1), 42–68.



- Schroeder, R. D., Giordano, P. C., & Cernkovich, S. A. (2010). Adult child-parent bonds and life course criminality. *Journal of Criminal Justice*, 38(4), 562–571.
- Norhawa, S. M. A. (2015). 6,800 kes jenayah siber di Malaysia, Boleh mengancam ekonomi negara. Utusan Online. <http://www.utusan.com.my/berita/jenayah/6-800-kes-jenayah-siber-di-malaysia-1.132952>
- Thorlindsson, T., Valdimarsdottir, M., & Jonsson, H. S. (2012). Community social structure, social capital and adolescent smoking: A multi-level analysis. *Health and Place*, 18(4), 796–804.
- Toby, J. (1957). Social disorganization and stake in conformity: Complementary factors in the predatory behavior of hoodlums. *Journal of Criminal Law, Criminology & Police Science*, 48(1), 12–17.
- Valdimarsdóttir, M., & Bernburg, J. G. (2015). Community disadvantage, parental network, and commitment to social norms: Multilevel study of self-reported delinquency in Iceland. *Journal of Research in Crime and Delinquency*, 52(2), 213–244.
- Warner, B. D. (2014). Neighborhood factors related to the likelihood of successful informal social control efforts. *Journal of Criminal Justice*, 42(5), 421–430.
- Warner, B. D., & Burchfield, K. (2011). Misperceived neighborhood values and informal social control. *Justice Quarterly*, 28(4), 606–630.
- Weisburd, D., & Eck, J. E. (2004). What can police do to reduce crime, disorder and Fear? *Annals of the American Academy of Political and Social Science*, 593(May), 42–65.
- Wheeler, L., Reis, H. T., & Nezlek, J. B. (1983). Loneliness, social interaction, and sex roles. *Journal of Personality and Social Psychology*, 45, 943–953.
- Wiatrowski, M. D., Griswold, D. B., & Roberts, M. K. (1981). Social control theory and delinquency. *American Sociological Review*, 46(5), 525.
- Wiley, S. A., & Esbensen, F. A. (2016). The effect of police contact: Does official intervention result in deviance amplification? *Crime and Delinquency*, 62(3), 283–307.
- Wray-Lake, L., Maggs, J. L., Johnston, L. D., Bachman, J. G., O'Malley, P. M., & Schulenberg, J. E. (2012). Associations between community attachments and adolescent substance use in nationally representative samples. *Journal of Adolescent Health*, 51(4), 325–331.
- Zhang, L., Zhou, D., Messner, S. F., Liska, A. E., Krohn, M. D., Liu, J., & Lu, Z. (1996). Crime prevention in a communitarian society: Bangjiao and tiao-jie in the people's republic of China. *Justice Quarterly*, 13(2), 199–222.

## Appendix: Construct and Measurement Item of Informal Social Control

**Attachment**

My family has always helped me with my problems.	1	2	3	4	5	6	7
My family often advised me to pray to God.	1	2	3	4	5	6	7
The University (Counselor / Lecturer / Student Affairs) encouraged me to share ideas, thoughts, and feelings.	1	2	3	4	5	6	7
The University (Counselor / Lecturer / Student Affairs) always helps me when I have problems.	1	2	3	4	5	6	7
My friends encourage me to share ideas, thoughts, and feelings.	1	2	3	4	5	6	7
Friends are always helpful when I'm having trouble.	1	2	3	4	5	6	7

**Beliefs**

I am a volunteer at the mosque/church/temple to help the local community.	1	2	3	4	5	6	7
I believe that every misconduct will be punished by the authorities.	1	2	3	4	5	6	7
I try to understand the law to avoid bad behaviour.	1	2	3	4	5	6	7
I am a volunteer with the law enforcement agencies (COP Partner, RELA, Malaysian Communications & Multimedia Commission, etc.).	1	2	3	4	5	6	7

**Involvement**

I often play/play video games with my family.	1	2	3	4	5	6	7
I often finish up college assignments early to get good grades.	1	2	3	4	5	6	7
I am committed to participating in university/club/association activities.	1	2	3	4	5	6	7
I often spend time with friends.	1	2	3	4	5	6	7

**Commitment**

I want to be the son of hope and the best for the family.	1	2	3	4	5	6	7
High CGPAs determine a brighter future.	1	2	3	4	5	6	7
I want to be loved by friends.	1	2	3	4	5	6	7
Helping friends to solve their problems is my priority.	1	2	3	4	5	6	7