

# The Influence of Entrepreneurial Behavior among Student Entrepreneurs: A Conceptual Framework

Norrini Muhammad<sup>1</sup>, Razli Che Razak<sup>2</sup>, Muhamad Saufi Che Rusuli<sup>3</sup>, Mimi Zazira Hashim<sup>4</sup>

<sup>1,2,3,4</sup>Faculty of Entrepreneurship and Business, Universiti Malaysia Kelantan, Malaysia,

<sup>1,4</sup>Faculty of Business and Management, Universiti Teknologi MARA Kelantan Branch, Malaysia

Corresponding Authors Email: norri5282@uitm.edu.my

**To Link this Article:** <http://dx.doi.org/10.6007/IJARBS/v12-i10/14988> DOI:10.6007/IJARBS/v12-i10/14988

**Published Date:** 03 October 2022

## Abstract

The high unemployment rate among university graduates has been a major source of concern for both the government and educational institutions. Universities have taken a broad-based education approach to developing students' skills and thinking capabilities. For example, it is the ability to supply diversified knowledge that allows students to generate chances such as value-driven actions, peer learning, inter-cultural awareness, social awareness, economic awareness, and many more. In line with education philosophy, developing entrepreneurial skills among university students is critical in coping with unemployment concerns. The purpose of this paper is to conceptually investigate the factors that influence entrepreneurial behavior (EB) among student entrepreneurs in higher education institutions (HEIs) in Malaysia. This study reviewed the literature on entrepreneurship education (EE) and the theory of planned behavior (TPB). Several recent studies have used TPB to assess entrepreneurial intentions among students. Numerous academic research have discovered that one of the factors influencing students' entrepreneurial intentions is entrepreneurship education. A comprehensive literature research was used to build the conceptual framework for this study.

**Keywords:** Entrepreneurial Intention, Entrepreneurial Behavior, Entrepreneurship Education, Theory of Planned Behavior

## Introduction

The Minister of Higher Education of Malaysia disclosed that a large proportion of the 260,701 graduates in 2020 hold bachelor's degrees and diplomas, or 41.08 percent and 41.04 percent of all graduates, respectively. Among all graduates, 60 percent were employed, 17.8 percent chose to pursue further education, 2.0 percent upgraded their skills, 4.6 percent were awaiting work placement, and 15.6 percent were unemployed (Ministry of Higher Education, 2021).

A number of initiatives have been put in place by the Malaysian government to support the growth of graduate entrepreneurs. The government published the Malaysia Education Blueprint 2015-2025 (Higher Education) or MEB (HE) in 2015, presenting a thorough restructuring plan for the higher education system. For instance, the government wants to enhance the system's accessibility, quality, equity, unification, and efficiency. The goal is to produce graduates who are holistic, balanced, and entrepreneurial, with knowledge and skills, as well as the ethics and morality, to meet the demands of Malaysia's expanding economy and to compete globally.

The Minister of Higher Education launched the Entrepreneurial Action Plan 2016-2020 for Higher Education Institutions (HEIs) as part of the MEB (HE). The action plan includes four initiatives based on two strategies under the education blueprint Shift 1, focusing on the development of students and system aspirations to produce holistic, balanced, and entrepreneurial graduates. High-impact education practices, a job creator framework, an improved student entrepreneur development support ecosystem, and strengthening the entrepreneur teaching force competency are among the four initiatives (Entrepreneurial Action Plan, Higher Education Institution 2016-2020, 2016). It resulted in 49,983 students were involved in business while studying, according to the Ministry of Higher Education, February 2021.

In recent years, youth unemployment in Malaysia has increased due to the majority of employers' demand for experienced workers. Young graduates are reported to have higher unemployment rates than non-graduates, with bachelor's degree holders having the highest unemployment rate among graduates (Ibrahim & Mahyuddin, 2016). As studied by Menon & Athanasoula-Reppa (2017), in order to deal with unemployment issues, the main strategy used by graduate students to improve their employment prospects is the acquisition of additional skills and competencies.

According to a survey that was carried out in Malaysia by the World Bank and Talent Corporation, employers regard soft skills to be an extremely important aspect when it comes to the recruitment of newly graduated candidates (Malaysia Economic: Boosting Trade Competitiveness, 2014). The survey found that employers were in agreement that recent graduates lacked the most in the areas of communication skills, followed by creative/critical thinking abilities, analytical skills, and problem-solving skills. This is due to the fact that the vast majority of graduates learn through lectures and academic textbooks, and while they are capable academically, they have limited opportunities to acquire practical experience by making use of the machinery, equipment and practical techniques associated with a profession (Anumnu, 2014). Because of this, the cultivation of students' soft skills is absolutely necessary for the expansion of their knowledge, comprehension, capabilities, and additional values. On the other hand, research on measuring soft skills is scarce and understudied (Chell, 2013). As a result, it is absolutely necessary to investigate the development of entrepreneurial abilities that influence students' entrepreneurial intentions and behaviors about entrepreneurship while they are enrolled in higher education institutions.

Therefore, HEIs must manage the available wealth of knowledge assets holistically, including policies, procedures, lecturers' expertise, curriculum and course contents, lectures, training lessons, real-live projects, and so on, in order to produce students who will either become entrepreneurs or professionals and consultants in their field of specialization (Anumnu, 2014). It was proven that entrepreneurship education has a positive impact on entrepreneur careers when the majority of students were self-employed and owned microbusinesses after ten years of graduation (Matlay, 2008). Furthermore, Alcaraz-Rodriguez et al (2014) discovered that the entrepreneurship program could significantly contribute to the development of some entrepreneur-related skills, specifically negotiation skills, the need for achievement, and initiative. As a result, this will reduce graduate unemployment while also assisting in the creation of job opportunities through the establishment of new ventures by graduates' entrepreneurs (Othman et al., 2012).

According to the Theory of Planned Behavior (TPB), entrepreneurial intention (EI), attitude toward behavior (ATB), subjective norm (SN) and perceived behavioral control (PBC) are the four cognitive elements that govern human behavior namely (Trivedi, 2016). The TPB is utilized extensively across various fields in order to a better understanding of individual human behavior. Numerous studies conducted throughout the past few years have investigated into the entrepreneurial intention of students through the utilization of TPB (Hongyi et al., 2017; Linan, 2008; Gieure et al., 2019; Trivedi, 2016; Tsordia & Papadimitriou, 2015; Zollo et al., 2017; Farooq, 2018; Aloulou, 2016; Manning, 2018; Varamaki et al., 2015; Joensuu-Salo et al., 2015; Feng et al., 2019; Buli & Yesuf, 2015; Galvao et al., 2018; Soomro & Shah, 2015). However, past research has revealed that the impacts of these three factors (attitude toward behavior, subjective norm, and perceived behavioral control) on the intention to start a business are inconsistent and conflicting (Trivedi, 2016; Armitage & Corner, 2001; Linan & Chen, 2006). In addition to this, there is still a gap in the literature that has not yet been filled concerning the relationship between intentions and behaviors (Gieure et al., 2019a). To the researcher's knowledge, there has been very little research on the determinants of factors leading to entrepreneurial intention and entrepreneurial behavior (EB). Moreover, numerous academic studies have found that entrepreneurship education is one of the factors that influence students' entrepreneurial intentions (Feng et al., 2019; Hongyi et al., 2017; Tsordia & Papadimitriou, 2015; Joensuu-Salo et al., 2015; Galvao et al., 2018). In spite of this, Yen-Chun & Tienhua (2017) discovered that only 17.3 percent of researchers in Asia Pacific region used TPB in their research, and the majority of them emphasized that entrepreneurship education either directly or indirectly contributes to greater entrepreneurial intentions. As a result, the following objectives are for this study:

- The TPB will be expanded by adding entrepreneurship education to measure entrepreneurial behavior alongside existing variables such as attitude toward behavior, subjective norm, perceived behavioral control, and entrepreneurial intention among student entrepreneurs.

## **Literature Review**

### *The Theory of Planned Behavior*

According to Ajzen (1991), attitude toward behavior, subjective norm, and perceived behavioral control can accurately predict intentions to engage in a variety of behaviors, and these intentions, along with perceptions of behavioral control, account for significant variance in actual behavior. According to the Theory of Planned Behavior (TPB), an

individual's behavior is influenced by three motivational factors namely, attitude toward behavior, subjective norm, and perceived behavioral control (Ajzen, 1991). The intention of the individual to engage in any situation determines their behavior. Additionally, intentional antecedents can have a direct influence on actual behavior (Joensuu-Salo et al., 2015). It is a reflection from intention to behavior. For instance, the stronger the intention, the more likely that the behavior will be performed. As a result, the TPB makes substantial contribution to entrepreneurship research, as entrepreneurial activity is a planned behavior and understanding intentions can aid in the identification of potential actions (Gieure et al., 2019b). According to the theory, an individual's attitude toward behavior is their evaluation of the influence of the desired behavior, which can be either positive or negative (Ajzen, 1991). The more favorable a person's attitude toward an action, the more likely he is to have an intention to engage in that action (Trivedi, 2016). Meanwhile, subjective norm refers to what the individual's social group thinks about performing the intended behavior (Ajzen, 1991). Lastly, perceived behavioral control relates to an individual's perception of how easy or difficult it is to perform the intended behavior (Ajzen, 1991). It refers to the individual's ability to control the actions required to perform behaviors (Gieure et al., 2019b). This implies that it can be used to predict behavior directly, and that those with a strong believe in entrepreneurship will be able to regulate and master the predicted behaviors. Moreover, as entrepreneurial intention is a crucial step in the formation of entrepreneurial behavior, it is considered as a predictor of actual entrepreneurial behavior (Ajzen, 1991). Figure 1 illustrates the original TPB.

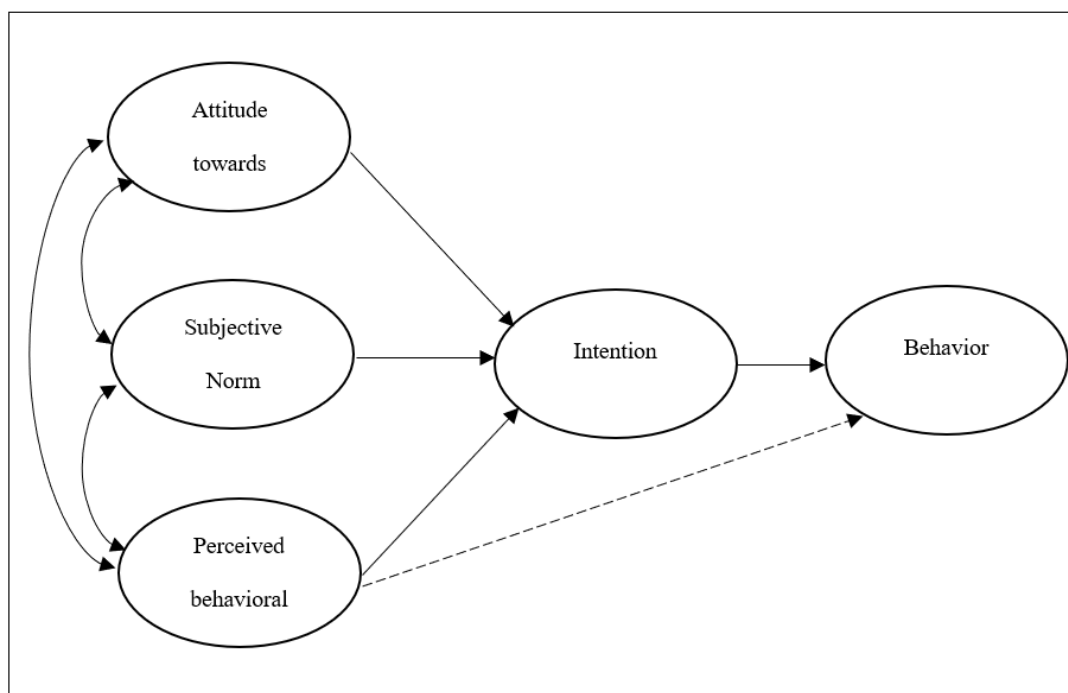

Figure 1: Theory of Planned Behavior, Ajzen 1991

### Previous Studies of Theory of Planned Behavior

Numerous previous studies have examined entrepreneurial intention among students in higher education. However, very little attention has been given on entrepreneurial behavioral studies. Inconsistency findings in previous studies could become the gaps for this study. The TPB consists of three antecedent variables (attitude toward behavior, subjective

norm and perceived behavioral control) to determine individual entrepreneurial intention. Majority of the past researchers used the three antecedent variables of TPB in predicting entrepreneurial intention (Hongyi et al., 2017; Gieure et al., 2019b; Trivedi, 2016; Aloulou, 2016; Farooq, 2018) however, there are some of the researchers used one antecedent of TPB to determine entrepreneurial intention (Manning, 2018) or two antecedents (Gieure et al., 2019a), of TPB in their studies. The findings discovered the three TPB antecedent variables are interrelated with each other. A few of researchers found that attitude toward behavior is significant to entrepreneurial intention while others are not significant. There are also found that subjective norm highly significant, moderately significant and insignificant to entrepreneurial intention. On the other hand, more or less researchers found that perceived behavioral control has positive influence or was not significant to entrepreneurial intention. For these inconsistency result, this study will use the three antecedent variables of TPB with the adding one external variable (entrepreneurship education) to the theory. Table 1 summaries the selected findings of previous studies on entrepreneurial intention and entrepreneurial behavior by using three antecedent variables of TPB.

Table 1  
*Selected Studies on Entrepreneurial Intention and Entrepreneurial Behavior*

Author	Constructs of TPB			Intention	Behavior	External Variables	Focus of the study	Major findings
	ATB	SN	PBC					
Gieure et al (2019a)	✓	✓		✓	✓	Entrepreneurial Skills	The relationship between entrepreneurial intentions and behavior	ATB does not directly and positively influence EI. SN had a highly significant effect on EI. Meanwhile, ES strongly and significantly influences ATB and SN. EI have a positive effect on individuals' behavior when starting a business.
Gieure et al (2019b)	✓	✓	✓	✓		Entrepreneurial Skills, University Environment	Entrepreneurial intentions in an international environment	ATB and SN directly and positively influence EI but not PBC. ES was found to influence EI directly and positively whilst influencing ATB. ES was significant to ATB UE has an insignificant influence on skills development.
Feng et al (2019)	✓	✓	✓	✓		Entrepreneurial Learning, Prior Exposure to Entrepreneurship (moderating variable)	The impacts of entrepreneurial learning on entrepreneurial intention	EL and EI were strongly and significantly correlated. The mediating effect of ATE, SN and PBC have a positive and significant relationship between EL and EI. The moderating role of PEE for the effects of education on ATB and PBC was significant, whereas the moderating effect of PEE for the effects of education on SN was not significant.

Author	Constructs of TPB					External Variables	Focus of the study	Major findings
	ATB	SN	PBC	Intention	Behavior			
Farooq (2018)	✓	✓	✓	✓	✓	Social Support, Entrepreneurial Skills	The significance of social support and entrepreneurial skills for determining entrepreneurial behavior	SS has a positive and significant direct effect on ATB, PBC, EI and EB. The significance of ES for explaining the overall variance in EB through EI. ES has a positive and significant direct effect on ATB, PBC and EI. However, a non-significant relation between SN and EI is also found.
Manning (2018)	✓			✓	✓	Entrepreneurial Orientation, Social Learning, Entrepreneurial Knowledge and Information	Enabling entrepreneurial behavior in a land-based university	Literature review
Galvao et al (2018)	✓	✓	✓	✓		Family Background, Entrepreneurship Education	Antecedents of entrepreneurial intentions among students in vocational training programs	Students' family background of entrepreneurship increases their EI. Among the three antecedents of TPB, only PBC had significant relationship with FB. ATB and PBC have a significant and positive relationship with EI but not SN. Surprisingly, EE does not influence students' EI. EE also has no effect on ATB, SN and PBC.
Hongyi et al (2017)	✓	✓	✓	✓		Entrepreneurship Education	The impact of entrepreneurial education on entrepreneurial intention of engineering students in Hong Kong	The four components of EE (why, what, how and who) have impact on ATB, SN, PBC and EI. The four EE components and the three TPB antecedent variables are also related to each other.
Trivedi (2016)	✓	✓	✓	✓		University Environment and Support	The role of university in shaping entrepreneurial intention	ATB and PBC have a strong and highly significant effect on EI. However, SN does not have any significant effect on EI. SN is significantly and positively related to ATB and PBC. UES is found to have a statistically significant relationship only with PBC. For ATB, it is found to have a non-significant relationship.
Aloulou (2016)	✓	✓	✓	✓		Demographic Characteristics	Predicting entrepreneurial intentions of final year Saudi university	All the main antecedents of EI contribute significantly to the explanation of intentions. SN has more influence than ATB and PBC on EI.

Author	Constructs of TPB					External Variables	Focus of the study	Major findings
	ATB	SN	PBC	Intention	Behavior			
Varamaki et al (2015)	✓	✓	✓	✓		Entrepreneurial Pedagogy	business students  The development of entrepreneurial potential among higher education students	SN has a more significant influence on attitudes and less on PBC. Demographic characteristics have an indirect influence on EI through SN and PBC.  Changes in ATB and PBC have a significant and positive impact on the change of EI whereas the relationship between change in SN and change in EI was not significant. EP had a significant and positive impact on the change in ATB. The change in ATB has also a positive impact on the change in PBC.
Joensuu-Salo et al (2015)	✓	✓	✓	✓	✓	Entrepreneurial Characteristics	Factors influencing student to start a firm	The best antecedents of EI was attitude followed by PBC. EC and SN are also significant, but their role is quite small. Gender, basic education, EC and PBC were significant to EB. Meanwhile ATB and SN were not significant to EB.
Linan (2008)	✓	✓	✓	✓		Entrepreneurial Skills	The effects skill and value perceptions on entrepreneurial intentions	ES were significant predictors of the three motivational antecedents of intention (PA, SN & PBC).

### Entrepreneurship Education

Entrepreneurship education is about teaching entrepreneurial skills and developing new and innovative plans (Rahim et al., 2015). The ultimate objective of entrepreneurial programs/courses is to increase students' awareness, which will lead to rise in entrepreneurship-related enthusiasm (Keat et al., 2011). Entrepreneurship education is essential for developing the mindsets, behaviors, skills, and talents of students, which will produce the entrepreneurs of the future (Chang & Rieple, 2013). Course contents such as effective communication, entrepreneurial negotiation, locating sources of financing, leadership, new product development, creativity and service-based and technological innovation as well as related activities, may be crucial for enhancing students' abilities to recognize, evaluate, and capitalize on business opportunities (Bereket & Wasihun, 2015). According to Garavan and O'Conneide (1994), the objectives of entrepreneurship education are to obtain useful entrepreneurship knowledge; to develop skills in the use of techniques, in the analysis of business environments, and the synthesis of action plans; to identify and stimulate entrepreneurial drive, talent and skills; to develop empathy and support for all unique aspects of entrepreneurship; to develop attitudes towards change; and to encourage new start-ups and other entrepreneurial endeavors.

The Ministry of Higher Education in Malaysia has made steps to require all students enrolled in HEIs to attend entrepreneurial courses. Additionally, these students are encouraged to take part in entrepreneurship-related events like training, seminars, short courses, conferences, live projects, business simulations, and many others. In order to put ideas into action and thereby increase their employability, students who receive entrepreneurship education have the opportunity to develop entrepreneurial knowledge, skills and attitudes (Zollo et al., 2017). The educational strategy used in Malaysian HEIs has to place more emphasis on learning outcomes that are concerned with enhancing knowledge, abilities, manners, and attitudes. For instance, the eight learning outcome domains specified by the Malaysian Qualification Framework (MQF) learning outcome domains (LOD), specifically by the Malaysian Qualification Agency (2015), had to be met by students. They include management and entrepreneurial skills (PLO 8). The consequences of entrepreneurial skills in this context include the capacity to learn via practical experience, creativity, innovation, opportunity recognition, internal locus of control, high achievement and endurance, and financial management. From this vantage point, the behavior approach presupposes that business owners can and ought to incorporate the skills they learn in entrepreneurship education (Farhangmehr et al., 2016).

Numerous studies have been undertaken on the effect of entrepreneurship education on the development of entrepreneurship among students (Secundo et al., 2017; Hassan et al., 2017; Lackeus, 2020; Mohamad et al., 2015). The constructs and findings of entrepreneurship education are summarized in Table 2.



Table 2

*Selected Studies on Entrepreneurship Education*

Author	Constructs of Entrepreneurship Education	Findings
Secundo et al (2017)	Explorative learning process, exploitative learning process, experiential and contextual learning process, and intuitive and sensing learning process	EL was successfully identified and promoted as a strategic approach to entrepreneurship in order to create a context for the dissemination of entrepreneurial culture in young students and graduates.
Hassan et al (2017)	Generalized entrepreneurial education, motivational entrepreneurial education, and augmented entrepreneurial education	There is a strong positive relationship between different kinds of entrepreneurial education on entrepreneurship development among students.
Lackeus (2020)	Experiential approaches: idea and artefact-creation pedagogy, value-creation pedagogy, and venture-creation pedagogy	Value-creation pedagogy had strong effects on entrepreneurial competencies, student motivation, and knowledge and skills acquisition.
Mohamad et al (2015)	Formal entrepreneurship education and informal entrepreneurship education	Entrepreneurship education (formal and informal) is found to have a positive and significant effect on entrepreneurship career options.

### **The Relationship between Entrepreneurship Education and Attitude Towards Behavior, Subjective Norms, Perceived Behavioral Control**

Entrepreneurship education and TPB are widely utilized in numerous fields. Several prior research have found that entrepreneurship education has a significant effect on attitude towards behavior, subjective norm, and perceived behavioral control (Paray & Sumit, 2020; Hongyi et al., 2017). In contrast, Galvao, Marques, & Marques (2018) discovered that EE was not significant for ATB and PBC, but it was significant to SN. The researcher therefore hypothesizes:

- $H^1$ : *Entrepreneurship education is significantly related to attitude toward behavior.*  
 $H^2$ : *Entrepreneurship education is significantly related to subjective norm.*  
 $H^3$ : *Entrepreneurship education is significantly related to perceived behavioral control*

### **The Relationship between Attitude Towards Behavior, Subjective Norms, Perceived Behavioral Control and Entrepreneurial Intention**

Previous research has discovered a positive and significant direct relationship between attitude towards behavior, subjective norms, perceived behavioral control, and entrepreneurial intention. Soomro and Shah (2015) discovered that all variables were positively and significantly related to potential entrepreneurs' entrepreneurial intentions. Thus, the researcher hypothesizes:

*H<sup>4</sup>: Attitude toward behavior is significantly related to entrepreneurial intention.*

*H<sup>5</sup>: Subjective norm is significantly related to entrepreneurial intention.*

*H<sup>6</sup>: Perceived behavioral control is significantly related to entrepreneurial intention.*

### **The Relationship between Entrepreneurship Education and Entrepreneurial Intention**

There is a strong correlation between different types of entrepreneurship education and student entrepreneurship development (Hassan et al., 2017). Previous researchers have found a correlation between entrepreneurship education and entrepreneurial intention (Hongyi et al., 2017; Feng et al., 2019). On the other side, Galvao et al (2018) discovered that entrepreneurship education had no influence on students' intentions to become entrepreneurs. Thus, the researcher hypothesizes:

*H<sup>7</sup>: Entrepreneurship education is significantly associated with entrepreneurial intention.*

### **The Relationship between Entrepreneurial Intention and Entrepreneurial Behavior**

Entrepreneurial intentions have a positive effect on individuals' behavior, and these intentions may lead to individuals starting their own businesses (Gieure et al., 2019a). Similarly, Farooq (2018) found a positive relationship between intention and planned behaviors that could be true for entrepreneurial behavior as well. Thus, the researcher hypothesizes:

*H<sup>8</sup>: Entrepreneurial intention is significantly related to entrepreneurial behavior.*

### **Conceptual Framework**

The conceptual framework exploits the established model based on theoretical contributions adapted from The Theory of Planned Behavior (Ajzen, 1991). The framework proposes to extend the TPB by incorporating one new construct namely entrepreneurship education. Therefore, Figure 2 is configured to depict how the variables relate to one another. The conceptual framework for this study is represented by the following framework:

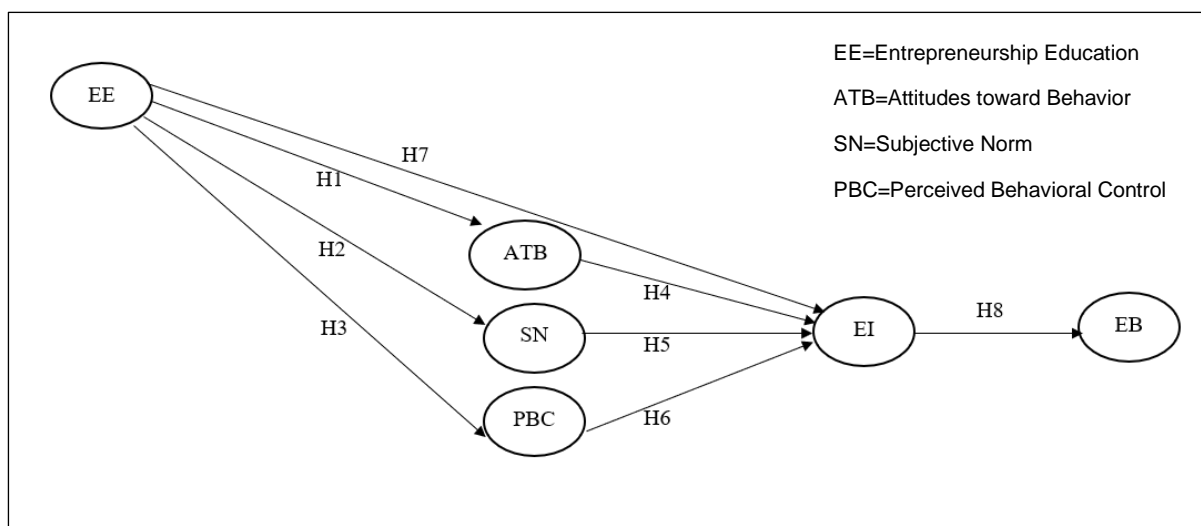

Figure 2: The Conceptual Framework Entrepreneurial Behavior Development Model

### Research Hypotheses

Based on the conceptual framework develop, there are eight hypotheses formulated as follows

H<sup>1</sup>: EE significantly related to ATB

H<sup>2</sup>: EE significantly related to SN

H<sup>3</sup>: EE significantly related to PBC

H<sup>4</sup>: ATB significantly related to EI

H<sup>5</sup>: SN significantly related to EI

H<sup>6</sup>: PBC significantly related to EI

H<sup>7</sup>: EE significantly related to EI

H<sup>8</sup>: EI significantly related to EB

### Conclusions

This paper conceptually explores the contributing factor of entrepreneurial behavior among students in HEIs. The TPB by Ajzen (1991), which was developed for the purpose of gauging entrepreneurial behavior, has seen extensive use among researchers. In spite of this, there is still a gap in the previous research concerning the relationship between intentions and behaviors. Additionally, entrepreneurial intention is used as a dependent variable in a significant portion of entrepreneurship research. This study will, in accordance with the recommendations of previous researchers, investigate the entrepreneurial behavior of students who are enrolled in an entrepreneurship course and who either plan to start a business, are in the process of starting a business, or have just recently started a business. Due to the rising unemployment rate in Malaysia, it is important for students to adopt entrepreneurial behaviors in order to become self-employed after graduation. They will be a greater awareness of entrepreneurial ventures among students as a result of the establishment of entrepreneurship education and the requirement that students attend this course. In order for students to get the most out of the education and the knowledge that is supplied by HEIs, they need to be able to effectively manage and completely utilize the knowledge in their innovation and practices.

## References

- Paray, A. Z., & Sumit, K. (2020). Does Entrepreneurship Education influence Entrepreneurial Intention Among Students in HEI's? The Role of Age, Gender and Degree Background. *Journal of International Education in Business*, 13(1), 55-72.
- Ajzen, I. (1991). The Theory of Planned Behavior. *Organizational Behavior and Human Decision Process*, 50(2), 179-211.
- Alcaraz-Rodriguez, R., Alvarez, M. M., & Villasana, M. (2014). Developing Entrepreneurial Competences in Students in the Life Sciences: The Lifetech Ad-Venture Program. *On the Horizon*, 22(3), 182-191.
- Aloulou, W. J. (2016). Predicting Entrepreneurial Intentions of Final Year Saudi University Business Students by Applying the Theory of Planned Behavior. *Journal of Small Business and Enterprise Development*, 23(4), 1142-1164.
- Anumnu, S. I. (2014). Knowledge Management and Development of Entrepreneurial Skills Among Students in Vocational Technical Institutions in Lagos, Nigeria. *The Electronic Journal of Knowledge Management*, 12(2), 137-161.
- Armitage, C. J., Conner, M. (2001) Efficacy of the theory of planned behavior: A meta-analytic review, *British Journal of Social Psychology* 40(4), 471-99.
- Bereket, M. B., & Wasihun, M. Y. (2015). Determinants of Entrepreneurial Intentions: Technical-Vocational Education and Training Students in Ethiopia. *Education + Training*, 57(8/9), 891-907.
- Buli, B. M., & Yesuf, W. M. (2015). Determinants of Entrepreneurial Intentions: Technical-Vocational Education and Training Students in Ethiopia. *Education + Training*, 57(8/9), 891-907.
- Chang, J., & Rieple, A. (2013). Assessing Students' Entrepreneurial Skills Development in Live Projects. *Journal of Small Business and Enterprise Development*, 20(1), 225-241.
- Chell, E. (2013). Review of Skill and the Entrepreneurial Process. *International Journal of Entrepreneurial Behaviour & Research*, 19(1), 6-31.
- Farhangmehr, M., Goncalves, P., & Sarmento, M. (2016). Predicting entrepreneurial motivation among university students: the role of entrepreneurship education. *Education + Training*, 58(7/8), 861-881.
- Farooq, M. S. (2018). Modelling the Significance of Social Support and Entrepreneurial Skills for Determining Entrepreneurial Behaviour of Individuals. *World Journal of Entrepreneurship, Management and Sustainable Development*, 14(3), 242-266.
- Feng, Z., Liqun, W., Hongyi, S., & Lo, C. T. (2019). How Entrepreneurial Learning Impacts One's Intention Towards Entrepreneurship: A Planned Behavior Approach. *Chinese Management Studies*, 13(1), 146-170.
- Galvao, A., Marques, C. S., & Marques, C. P. (2018). Antecedents of Entrepreneurial Intentions among Students in Vocational Training Programmes. *Education + Training*, 60(7/8), 719-734.
- Garavan, T. N., & O'Conneide, B. (1994). Entrepreneurship Education and Training Programmes: A Review and Evaluation Part 1. *Journal of European Industrial Training*, 18, 3-12.
- Gieure, C., Benavides-Espinosa, M. D., & Roig-Dobon, S. (2019). The Entrepreneurial Process: The Link between Intentions and Behaviour. *Journal of Business Research*, 1-8.
- Gieure, C., Benavides-Espinosa, M. D., & Roig-Dobon, S. (2019). Entrepreneurial Intentions in an International Environment. *International Journal of Entrepreneurial Behavior & Research*, 25(8), 1605-1620.

- Hassan, S., Khan, A. E., & Un Nabi, M. (2017). Entrepreneurial Education at University Level and Entrepreneurship Development. *Education + Training*, 59(7/8), 888-906.
- Hongyi, S., Choi, T. L., Bo, L., & Yuen, L. B. (2017). The Impact of Entrepreneurial Education on Entrepreneurial Intention of Engineering Students in Hong Kong. *Management Decision*, 1371-1393.
- Joensuu-Salo, S., Varamaki, E., & Viljamaa, A. (2015). Beyond Intentions - What Makes A Student Start A Firm? *Education + Training*, 57(8/9), 853-873.
- Keat, O. Y., Selvarajah, C., & Meyer, D. (2011). Inclination towards entrepreneurship among university students: an empirical study of Malaysian university students. *International Journal of Business and Social Science*, 2(4), 206-220.
- Lackeus, M. (2020). Comparing The Impact of Three Different Experiential Approaches to Entrepreneurship in Education. *International Journal of Entrepreneurial Behavior & Research*, 26(5), 937-971.
- Linan, F., Chen, Y., (2006) Testing the entrepreneurial intention model on a two-country sample. Working paper series Document de Treball núm. 06/7.
- Linan, F. (2008). Skill and Value Perceptions: How Do They Affect Entrepreneurial Intentions? *International Entrepreneurship and Management Journal*, 257-272.
- Malaysia Economic Monitor: Boosting Trade Competiveness. (2014). The World Bank.
- Manning, L. (2018). Enabling Entrepreneurial Behavior in a Land-Based University. *Education+Training*, 60(7/8), 735-748.
- Matlay, H. (2008), "The impact of entrepreneurship education on entrepreneurial outcomes", *Journal of Small Business and Enterprise Development*, 15(2), 382-396.
- Menon, M. E., & Athanasoula-Reppa, A. (2017). Managing graduate unemployment: the case of education students in Cyprus. *Higher Education, Skills and Work-Based Learning*, 7(2), 168-178.
- Ministry of Higher Education. (2021). *Higher Education Statistic 2020: Chapter 7 Graduate Tracer Study*.
- Mohamad, N., Lim, H.-E., Yusof, N., & Soon, J.-J. (2015). Estimating the effect of entrepreneur education on graduates' intention to be entrepreneurs. *Education + Training*, 57(8/9), 874-890.
- Ibrahim, M. D. H., & Mahyuddin, M. Z. (2016). *Youth Unemployment in Malaysia: Developments and Policy Considerations*. Annual Report Bank Negara Malaysia.
- Othman, N., Hashim, N., & Ab Wahid, H. (2012). Readiness Towards Entrepreneurship Education: Students and Malaysian Universities. *Education and Training*, 697-708.
- Rahim, H. L., Abdul Kadir, M. A., Abidin, Z. Z., Junid, J., Kamaruddin, M. L., Lajin, M. N. F., . . . Bakri, A. A. (2015). Entrepreneurship education in Malaysia: a critical review. *Journal of Technology Management and Business*, 2(2).
- Secundo, G., Del Vecchio, P., Schiuma, G., & Passiante, G. (2017). Activating Entrepreneurial Learning Process for Transforming University Students' Idea Into Entrepreneurial Practices. *International Journal of Entrepreneurship Behavior & Research*, 23(3), 465-485.
- Soomro, B. A., & Shah, N. (2015). Developing Attitudes and Intentions among Potential Entrepreneurs. *Journal of Enterprise Information Management*, 28(2), 304-322.
- Trivedi, R. (2016). Does University Play Significant Role in Shaping Entrepreneurial Intention? A Cross-Country Comparative Analysis. *Journal of Small Business and Enterprise Development*, 23(3), 790-811.

- Tsordia, C., & Papadimitriou, D. (2015). The Role of Theory of Planned Behavior on Entrepreneurial Intention of Greek Business Students. *International Journal of Synergy and Research*, 4(1), 23-37.
- Varamaki, E., Joensuu, S., Tornikoski, E., & Viljamaa, A. (2015). The Development of Entrepreneurial Potential among Higher Education Students. *Journal of Small Business and Enterprise Development*, 22(3), 563-589.
- Yen-Chun, J. W., & Tienhua, W. (2017). A decade of entrepreneurship education in the Asia Pacific for future directions in theory and practice. *Management Decision*, 55(7), 1333-1350.
- Zollo, L., Laudano, M. C., Ciappei, C., & Zampi, V. (2017). Factors Affecting Universities' Ability to Foster Students' Entrepreneurial Behavior. *Journal of Management Development*, 36(2), 268-285.