

# Measuring E-Learning Antecedents in the Context of Higher Education through Exploratory and Confirmatory Factor Analysis

Mohamad Aidil Hasim

Department of Accountancy and Business, Tunku Abdul Rahman University of Management and Technology, Johor Branch, Jalan Segamat / Labis, 85000, Segamat, Johor, Malaysia.  
Email: aidilhasim01@gmail.com

Juhaini Jabar\*

Centre for Technopreneurship Development, Faculty of Technology Management and Technopreneurship, Universiti Teknikal Malaysia Melaka, Hang Tuah Jaya, 76100 Durian Tunggal, Melaka, Malaysia.  
Email: juhaini@utem.edu.my

Vincent Woo Ming Wei

Department of Accountancy and Business, Tunku Abdul Rahman University of Management and Technology, Johor Branch, Jalan Segamat / Labis, 85000, Segamat, Johor, Malaysia.  
Email: woomw@tarc.edu.my

To Link this Article: <http://dx.doi.org/10.6007/IJARBSS/v14-i9/22670>

DOI:10.6007/IJARBSS/v14-i9/22670

**Published Date:** 12 September 2024

## Abstract

The aim of this study is to develop a reliable and valid instrument for assessing the e-learning antecedents through Exploratory Factor Analysis (EFA) and Confirmatory Factor Analysis (CFA). The questionnaire used in this study was adapted and modified using a 7-point Likert scale and validated by eight e-learning experts. A pilot test with 102 responses was conducted using a cross-sectional design, and the data were analyzed using EFA in SPSS version 29. The results showed that the factor loadings for all construct items exceeded the threshold of 0.5. Furthermore, Bartlett's test of sphericity was highly significant ( $p < .001$ ), and the Kaiser-Meyer-Olkin (KMO) measure for sampling adequacy was 0.896, indicating an excellent sample size. Subsequently, 1,092 responses from the field study were analyzed using CFA with AMOS version 28. The results confirmed that the instrument met all CFA criteria, demonstrating its robust reliability in assessing the e-learning antecedents in the context of higher education. This study contributes to the existing body of knowledge by offering a comprehensive overview of the EFA and CFA methodologies, leading to the development of a reliable measurement. Finally, it recommends that future research employ alternative analytical tools

to evaluate the instruments used in this study and compare the findings with the conclusions drawn.

**Keywords:** Confirmatory Factor Analysis, E-Learning Antecedents, Exploratory Factor Analysis, Higher Education.

### **Introduction**

Currently, digital technology in education is playing an increasingly significant and comprehensive role in the educational process (Wagiran et al., 2022). According to Hasim et al (2022), there is a shift observed from the conventional approach to education towards the adoption of e-learning. Moreover, the current pandemic circumstances exacerbate the consequences associated with the adoption of e-learning, leading to its swift integration in the field of education (Choudhury & Pattnaik, 2020). E-learning is a structured and systematic learning approach that relies on electronic web-based platforms, despite its broad and inclusive description. The educational process in this approach encompasses four essential elements: learning material, information and communication technology (ICT) such as internet connection, online platforms, and video audio teleconferencing (Holmes et al., 2019). The learning model described in this study is characterized by a highly organized learning approach (Saripudin et al., 2020). The availability of crucial learning resources is a notable benefit in promoting an effective learning process for both students and educators (Priatna et al., 2020). Efficiency has a crucial role in enhancing the effectiveness of learning, hence facilitating easier and quicker achievement (El-Sabagh, 2021). Numerous relevant researches support the notion that e-learning exhibits a wide range of attributes and facilitates the creation of a learning environment that is innovative, communicative, active, independent, reflective, and collaborative (Wali & Popal, 2020).

Despite the numerous advantages attributed to the utilization of e-learning, it has been observed that engaged in online learning may encounter a decline in motivation, delayed provision of feedback, and insufficient levels of support. This is primarily due to the asynchronous nature of most online learning environments, where instructors are not readily accessible to address students' needs. Consequently, students often report feelings of isolation from their instructors and peers, resulting in a tendency towards passivity in their learning engagement during online classes (Hasim et al., 2022; Vavasseur et al., 2020). The impact of technology on online learning has been significant, potentially impeding instructor-student engagement and fostering feelings of isolation (Sarkam et al., 2022). The aforementioned outcomes clearly demonstrate that students were ill-equipped or inadequately prepared to adapt to the shift towards fully online learning, leading to a varied perception among students on the implementation of e-learning (Hasim et al., 2020; Kim et al., 2019).

Although, e-learning platform have gained acceptance among higher educational institutions (HEIs) in Malaysia, however, due to lack of technical support, fund to improve infrastructure, and absence of an e-learning institutional strategy, the incorporation of e-learning into HEIs has become one of the biggest challenges in implementing e-learning platform (Shahmoradi et al., 2018; Ugur & Turan, 2018; Afolabi & Uhomoibhi, 2015). As a result, this matter has led to a lack of a comprehensive framework model that has examined the understanding of e-learning and how it affects usage behavior towards e-learning performance in Malaysia (Al-

Rahmi et al., 2018; Al-Rahmi et al., 2015). In fact, there is a scarcity of research that comprehensively examines and characterizes the impact of HEI models in Malaysia on the effectiveness of e-learning usage behavior towards performance (Wong et al., 2020; Anthony et al., 2019). In order to address these problems, a new framework will be developed by combining the unified theory of acceptance and use of technology (UTAUT) model with the task-technology fit (TTF) model. The current investigation employed the unified theory of acceptance and use of technology (UTAUT) model, as originally proposed by Venkatesh et al., (2003) and the task-technology fit (TTF) model, as originally proposed by Goodhue and Thompson (1995), as the underlying theories for developing the research model.

This study integrated TTF with UTAUT as an appropriate conceptual framework to provide a contribution and effective model which capable to identify the determinant factors that influence e-learning performance (Hasim et al., 2023; Hasim et al., 2022) as well as distinguishing a reliable instrument such as (performance expectancy, effort expectancy, social influence, personal innovativeness, task characteristics and technology characteristics). Therefore, this study is intended to discover the appropriate items for inclusion in a questionnaire survey. Precisely, to devise a valid and reliable instrument for assessing e-learning antecedents in the context of HEIs through exploratory factor analysis (EFA) and confirmatory factor analysis (CFA).

## **Methodology**

### *Research Design and Sampling*

The data in this study was collected through the utilization of a self-administered survey. The questionnaire utilized in this research was adjusted and revised to align with the specific contextual requirements, drawing upon previous studies as a foundation (Hasim et al., 2022; Alkawsii et al., 2021; Twum et al., 2021; Buabeng-Andoh & Baah, 2020; Samsudeen & Mohamed, 2019; Bere, 2018; Wijesundara & Xixiang, 2018; Tan, 2013; Venkatesh et al., 2003; Goodhue & Thompson, 1995). A cross-sectional survey was conducted, resulting in the collection of data from a total of 133 respondents. However, the sample size for this study was limited to 102 students following the rigorous screening process. The participants in this study are students specializing in the social sciences field from the Faculty of Technology Management and Technopreneurship at Universiti Teknikal Malaysia Melaka. They were chosen for inclusion in the study through a simple random sampling method.

Based on the research conducted by Krejcie and Morgan (1970), it has been established that when the population size reaches 400, a minimum sample size of 196 respondents is necessary to ensure the attainment of a sufficiently representative sample. Given that the purpose of this survey was to conduct an exploratory factor analysis (EFA), a sample size of 102 respondents was deemed adequate. The selection of respondents was conducted using a simple random sampling technique, which was deemed as the most appropriate method for obtaining the data. This approach ensured that each potential respondent had an equal probability of being selected (Sekaran & Bougie, 2016).

The survey comprised six constructs. The first construct pertained to performance expectancy and consisted of six items. The second construct focused on effort expectancy and comprised five items. The third construct examined social influence and included five items. The fourth

construct explored personal innovativeness and consisted of five items. The fifth construct investigated task characteristics and comprised six items. Lastly, the sixth construct examined technology characteristics and included five items. The Likert scale ranging from 1 to 7 was employed for all dimensions in this study to ensure consistency and facilitate comparisons of the findings. The rationale to implement a seven-point scale was based on existing scholarly literature, which suggests that a seven-point scale offers enhanced precision, usability, and alignment with a respondent's genuine assessment (Hasim et al., 2023; Taherdoost, 2019). Considering the numerous benefits, particularly in comparison to higher-order items, it may be argued that seven-point items present themselves as the most optimal choice for questionnaires employed in usability studies (Finstad, 2010). Scholars such as Johns (2010) and Bouranta et al., (2009) have proposed that the utilization of a seven-point scale would be better suitable for survey methodologies. Hence, a seven-point scale was employed in the present study.

Furthermore, a preliminary assessment was carried out to evaluate the instrument's content validity, face validity, and criteria validity. The review of content validity was carried out by professionals in the relevant field, whereas face validity was assessed by experts in the English language. Lastly, criteria validity was evaluated by a statistics expert. In order to enhance the face and content validity as well as the reliability of this study, the researchers made modifications to all questions, taking into account the pre-test findings. These modifications were informed by the researchers' observations and comprehension of the subject matter (Hasim et al., 2019). After the validation method was concluded, the data were gathered. The data in this study were gathered through the utilization of an online survey. A total of 133 individuals participated in the completion of the online questionnaire; however, 31 of these replies were deemed incomplete and hence excluded from the analysis. Hence, a total of 102 respondents' data was utilized to conduct an exploratory factor analysis (EFA) with the purpose of investigating the presence of a shared underlying factor among the items representing a construct, as well as assessing its unidimensionality (Knekta et al., 2019; Hoque et al., 2018).

Lastly, the survey successfully garnered a total of 1105 replies, of which 1092 were determined to be legitimate. The present study collected a total of 1092 responses from the Malaysian technical university network (MTUN), which includes Universiti Teknikal Malaysia Melaka (UTeM), Universiti Tun Hussein Onn Malaysia (UTHM), Universiti Malaysia Pahang (UMP), and Universiti Malaysia Perlis (UniMAP). To provide greater precision, this investigation exclusively utilized data from first-year students enrolled in the social science program at each MTUN during the entry period of 2021/2022. The participants were recruited using a simple random sample plan. The data was analyzed using the statistical package for social science (SPSS) and the analysis of moment structures (AMOS). The researchers employed SPSS for the purpose of data screening and conducting an exploratory factor analysis (EFA) and AMOS was utilized to assess the measurement model's validity, reliability, and unidimensionality using confirmatory factor analysis (CFA) (Anuar et al., 2023; Sarkam et al., 2022).

## Findings

### *Exploratory Factor Analysis (EFA)*

In this study, exploratory factor analysis (EFA) was employed to examine the dimensionality of constructs. The items used in this study were adapted from previous studies, and some modifications were made to align them with the specific requirements of the current research. The exploratory factor analysis (EFA) procedure includes several key components. These components consist of the mean score and standard deviation for each item, the Kaiser-Meijer-Olkin (KMO) measure of sampling adequacy, the total variance explained, the factor loading for all items, the dimensionality of items within their respective components, and finally, Cronbach's Alpha as a measure of internal consistency for the construct (Baistaman et al., 2020; Ehido et al., 2020; Hasim et al., 2020).

In this study, each item was evaluated using a seven-point Likert scale, with a rating of 1 indicating "strongly disagree" and a rating of 7 indicating "strongly agree." In this context, this study has utilized exploratory factor analysis (EFA) in conjunction with principal component analysis (PCA) to assess the e-learning antecedent. The antecedent comprises six constructs, namely performance expectancy, effort expectancy, social influence, personal innovativeness, task characteristics, and technology characteristics. The researchers employed PCA to evaluate these 32 items associated with the aforementioned constructs. The results presented in Table 1 demonstrate that Bartlett's Test of Sphericity yields a significant result ( $P < 0.05$ ). Additionally, the KMO Measure of Sampling Adequacy is calculated to be 0.896, surpassing the minimum threshold of 0.6 as recommended by Ghani et al., (2022) and Awang (2012). This suggests that the sample size is sufficient (Shkeer & Awang, 2019; Hoque et al., 2018). The significance of the Bartlett Test and the Kaiser-Meyer-Olkin (KMO) value more than 0.6 both indicate the appropriateness of the existing data, suggesting that the factors used in the analysis were really factorable.

Furthermore, the analysis presented in Table 2 indicates that six components, each having an eigenvalue greater than 1.0, account for approximately 79.775% of the total variation. The degree of explained variation is deemed satisfactory as it surpasses the minimum threshold of 60% as established by previous studies (Baistaman et al., 2020; Yahaya et al., 2018). Hence, the substantial proportion of variation accounted for suggests a robust association among the factors examined in this research. The outcomes of the exploratory factor analysis (EFA), utilizing the pattern matrix, were organized into six distinct factors, as illustrated in Table 3. The factor loadings for each item exhibited high values, often exceeding 0.5, as reported in previous studies (Ehido et al., 2020; Yahaya et al., 2018). Thus, all items were retained adequately. In addition, the scree plot depicted in Figure 1 indicates that a six-component solution is a plausible assumption, as found using the exploratory factor analysis (EFA) process. Finally, the internal reliability results presented in Table 4 indicate that the Cronbach's alpha coefficient for all constructs above the recommended threshold of 0.7, suggesting that all the items inside the constructs were considered acceptable and reliable to use further (Hasim et al., 2022; Hasim et al., 2020; Taber, 2018).

Table 1  
*KMO and Bartlett's test*

Kaiser-Meyer-Olkin Measure of Sampling Adequacy	0.896
Approx. Chi-Square	4282.269
Bartlett's Test of Sphericity	df
	496
	Sig.
	0.000

Table 2  
*Total variance explained*

Factor	Initial Eigenvalues			Extraction Sums of Squared Loadings			Rotation Sums of Squared Loading <sup>a</sup>
	Total	% of Variance	Cumulative %	Total	% of Variance	Cumulative %	Total
1	15.978	49.931	49.931	15.780	49.312	49.312	11.319
2	3.615	11.297	61.229	3.497	10.928	60.240	6.624
3	2.298	7.183	68.411	2.083	6.508	66.748	12.399
4	1.980	6.188	74.599	1.766	5.517	72.266	11.968
5	1.508	4.714	79.313	1.310	4.092	76.358	9.677
6	1.305	4.078	83.391	1.094	3.417	79.775	9.793

Extraction Method: Principal Axis Factoring.

a. When factors are correlated, sums of squared loadings cannot be added to obtain a total variance.

Table 3  
*EFA of e-learning antecedents*

Item	Factor					
	1	2	3	4	5	6
PE1: I find online learning to be an effective method of education.	0.939					
PE2: I am aware that online learning assists me to complete my learning tasks faster.	0.919					
PE4: I know online learning enhances my efficiency.	0.900					
PE3: I am acknowledged that online learning strengthens my learning capabilities.	0.845					
PE6: I know that online learning enhances my motivation to learn.	0.841					
PE5: I am aware that the online learning improves my learning outcomes.	0.824					
EE5: I am acknowledged that my interaction with the online learning is understandable.		0.994				
EE2: I am aware that online learning assists me in enhancing my skills.		0.977				

EE1: I know online learning is easy to use.	0.966
EE4: I know my interaction with the online learning is clear.	0.887
EE3: I become proficiency at using an online learning.	0.730
TC4: Through the online learning, I always have the option of interacting via audio, video, graphics, or text.	0.963
TC5: I acknowledge that the technological components of the online learning are sufficient to facilitate effective learning.	0.929
TC6: I acknowledged my familiarity with the fact that the online learning offers superior functionalities for synchronizing data and sharing folders.	0.873
TC7: I am acknowledged that online learning enables cross-device and cross-operating-system access to files and information.	0.843
TC2: I believe that online learning is a convenient platform because it allows me to study at anytime and anywhere.	0.787
TC3: Through the use of online learning, I am consistently provided with the option to interact either synchronously or asynchronously.	0.653
TS1: I acknowledge that the utilization of online learning grants me the flexibility to study at my convenience, regardless of time and location.	1.002
TS5: I often require timely feedback during learning process.	0.994
TS3: I often acquire knowledge via acquiring information from others.	0.929
TS4: During the learning process, I often require interaction.	0.885
TS2: I often solicit guidance from others regarding effective strategies for managing my learning difficulties.	0.766
PI1: I consider myself to be someone who is open to experimenting with different platforms for online learning.	0.965
PI3: I have no qualms about putting my skills to the test on an online learning platform.	0.933

PI5: While I'm studying, I really prefer to engage in creative learning approaches (such as online learning).	0.844
PI2: In most cases, I am pioneering among my peers in utilizing an exciting online learning.	0.708
PI4: I am someone who approaches the online learning with an open mind and a willingness to try new things.	0.510
S15: In general, the university has supported the use of the online learning.	0.920
S13: My lecturers think that I should use the online learning.	0.891
S11: I am advised by influential individuals to consider adopting online learning.	0.767
S14: The assistance of the department administration in utilizing the online learning is valuable.	0.676
S12: Online learning is recommended by individuals who hold significance in my life.	0.580

---

Extraction Method: Principal Axis Factoring  
 Rotation Method: Promax with Kaiser Normalization  
 a. Rotation converged in 6 iterations

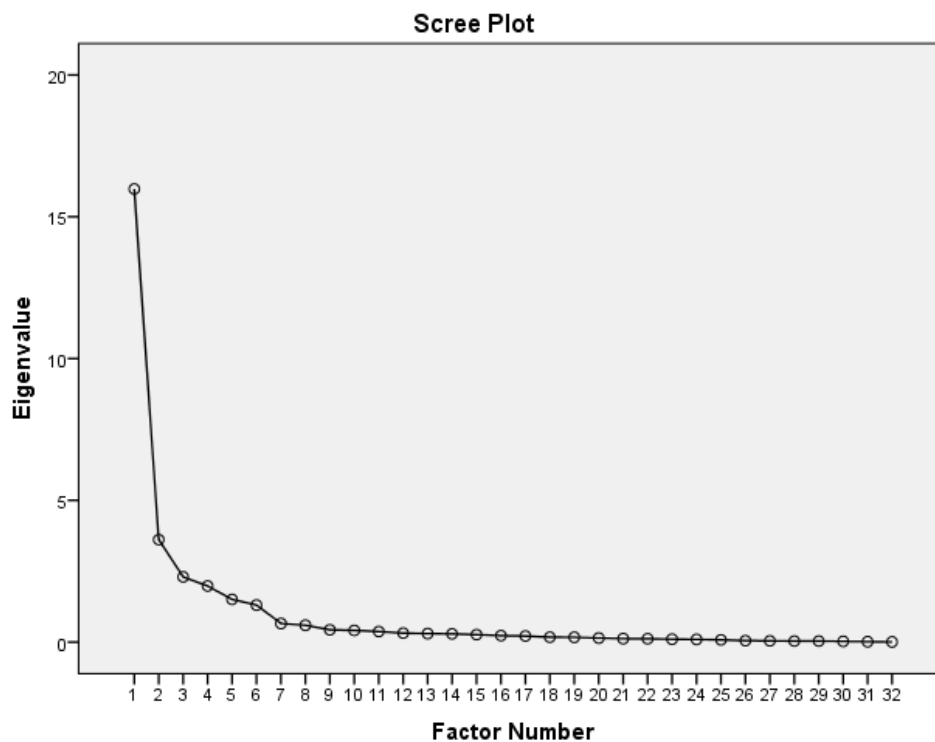

Figure 1. Scree Plot (Six-Factor Extraction)



Table 4

*Reliability results*

Construct	Number of items	Cronbach's alpha
Performance Expectancy (PE)	6	0.948
Effort Expectancy (EE)	5	0.967
Social Influence (SI)	5	0.905
Personal Innovativeness (PI)	5	0.931
Technology Characteristics (TC)	6	0.951
Task Characteristics (TS)	5	0.970

**Confirmatory Factor Analysis (CFA)**

This study necessitated the validation of all measurement models pertaining to latent constructs in terms of three key aspects: (1) unidimensionality, (2) validity, and (3) reliability (Anuar et al., 2023; Mohamad et al., 2018). The approach referred to in this context is commonly known as confirmatory factor analysis (CFA). The measuring model pertaining to the latent constructs was necessitated to adhere to three distinct forms of validity, namely convergent validity, construct validity, and discriminant validity (Yusof et al., 2017). The assessment of convergent validity entails the computation of the average variance extracted (AVE). The evaluation of construct validity involves the calculation of fitness indices for the measurement model and the Discriminant Validity Index Summary was utilized to assess the presence of discriminant validity. Lastly, the assessment of composite reliability (CR) was conducted in order to ascertain the dependability of e-learning antecedents, as it presented a superior alternative to the traditional approach of computing Cronbach Alpha for analysis (Anuar et al., 2023; Sarkam et al., 2022; Yusof et al., 2017; Awang et al., 2018; Awang, 2015).

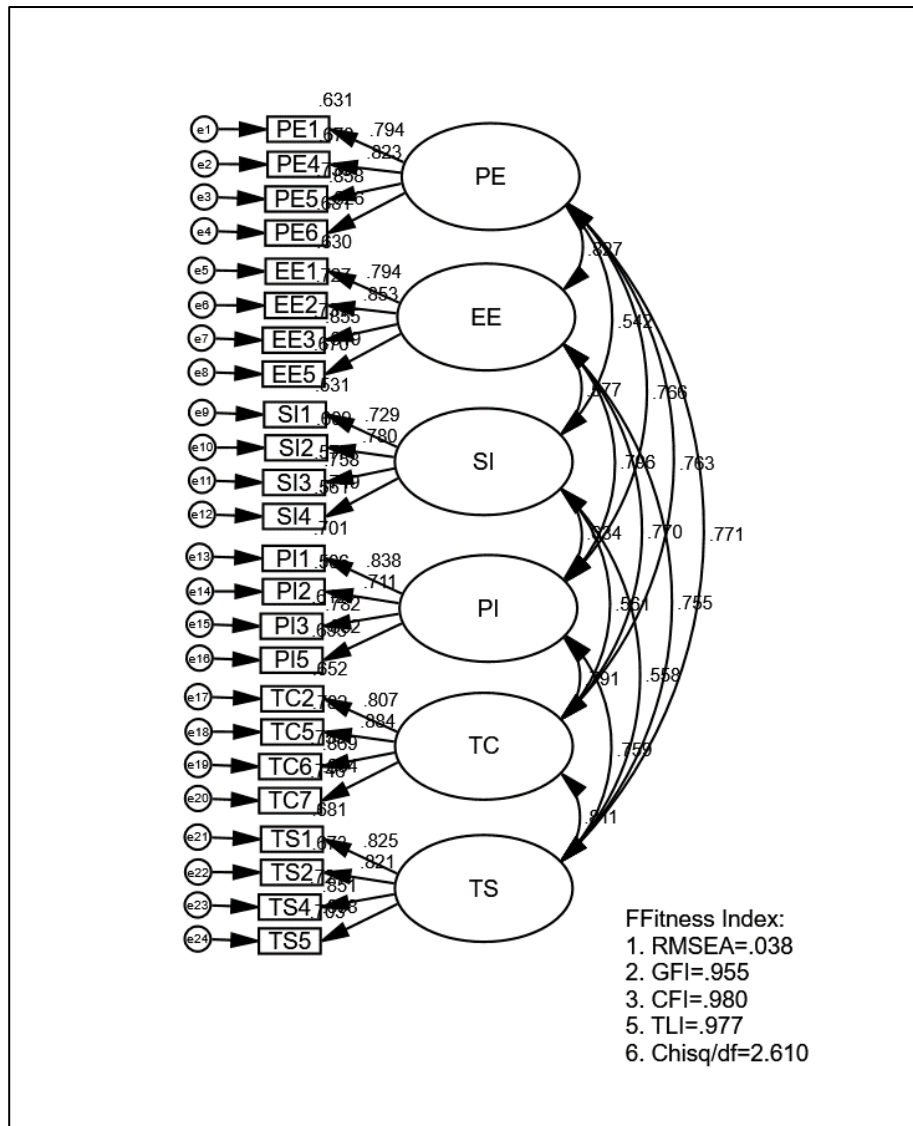

Figure 2. Result from CFA procedure

Figure 2 depicts the constructs that were subjected to CFA six-factor congeneric model, utilizing the field data (n=1092) prior to measurement model fit. Awang (2015) posits that the achievement of unidimensionality is contingent upon the presence of measuring items for the respective constructs that exhibit appropriate factor loading values exceeding 0.06. Conversely, items within the measurement model that display low factor loading values should be eliminated until the fit indices are successfully obtained (Anuar et al., 2023). The new factor loadings were depicted in Table 5, after CFA was conducted in this study.

Table 5

*New factor loadings*

Construct	Items	Factor loading (>.6)
Performance Expectancy (PE)	PE1	0.794
	PE4	0.823
	PE5	0.858
	PE6	0.826
Effort Expectancy (EE)	EE1	0.794
	EE2	0.853
	EE3	0.855
	EE5	0.819
Social Influence (SI)	SI1	0.729
	SI2	0.780
	SI3	0.758
	SI4	0.749
Personal Innovativeness (PI)	PI1	0.838
	PI2	0.711
	PI3	0.782
	PI5	0.832
Task Characteristics (TC)	TC2	0.807
	TC5	0.884
	TC6	0.869
	TC7	0.864
Technology Characteristics (TS)	TS1	0.825
	TS2	0.821
	TS4	0.851
	TS5	0.838

In this analysis, PE2, PE3, EE4, SI5, PI4, TC3, TC4, and TS3 were eliminate due to a low factor loading (<0.6) which would affect the fitness of the model (Shrestha, 2021; Shau, 2017). Hence, 24 items were retained after CFA was conducted.

**Convergent Validity**

Convergent validity refers to a set of measures that are assumed to assess a particular construct (Awang et al., 2018; Awang, 2015; Hair et al., 2014; Kline, 2011). According to Brown (2006), convergent validity pertains to the degree of association across items that are anticipated to represent a shared underlying construct, as evidenced by the average variance extracted (AVE). For acceptance, the AVE value must surpass the acceptance threshold of 0.5, as indicated by Awang et al., (2018) and Fornell & Larcker (1981). Data shown in Table 6, the average variance extracted (AVE) for each construct surpassed the established threshold of 0.5. Therefore, it may be deduced that the model has successfully demonstrated convergent validity.

Table 6

*Average Variance Extracted*

Construct	AVE (> .5)
Performance Expectancy (PE)	0.682
Effort Expectancy (EE)	0.690
Social Influence (SI)	0.569
Personal Innovativeness (PI)	0.628
Task Characteristics (TC)	0.734
Technology Characteristics (TS)	0.695

**Construct Validity**

Construct validity is reached when all of a model's fitness measures meet the necessary level (Anuar et al., 2023; Awang et al., 2018). The assessment of a construct's fitness can be demonstrated by examining three categories of model fit, specifically: absolute fit indices, incremental fit indices, and parsimonious fit indices. The commonly employed indicators in this context are the root mean square of approximation (RMSEA), comparative fit index (CFI), and normed Chi-Square ( $\chi^2/df$ ), as observed in e-learning studies (Abbad et al., 2021; Ho et al., 2020).

As demonstrated in Table 7, all of the fitness indices in the study meet or surpass the necessary requirements. Firstly, the RMSEA value of 0.038 is lower than the threshold of 0.08, indicating a good absolute fit. Secondly, the CFI value of 0.980 exceeds the recommended value of 0.90, demonstrating a satisfactory incremental fit. Lastly, the parsimonious fitness index, measured by  $\chi^2/df$ , is 2.610, which is below the recommended threshold of 5.0 as suggested by Hu & Bentler (1990).

Table 7

*Fitness Indices*

Category	Name of Index	Level of acceptance	Result	Status
Absolute Fit Index	RMSEA	RMSEA < 0.08	0.038	Fulfilled
Incremental Fit Index	CFI	CFI > 0.90	0.980	Fulfilled
Parsimonious	Chisq ( $\chi^2/df$ )	$\chi^2/df$ < 5.0	2.610	Fulfilled

**Discriminant Validity**

The researchers evaluated the discriminant validity of the survey in order to verify that the model does not include any redundant constructs (Anuar et al., 2023; Sarkam et al., 2022; Awang et al., 2018). The present study involved the development of a comprehensive description of the discriminant validity index, with the aim of determining its applicability and effectiveness. The values located on the diagonal (emphasized in bold) correspond to the square root of the average variance extracted (AVE) for each construct. Conversely, the remaining values indicate the correlation between each pair of constructs, as illustrated in Table 8.

Table 8

*Discriminant validity index*

Construct	PE	EE	SI	PI	TC	TS
PE	<b>0.682</b>					
EE	0.293	<b>0.690</b>				
SI	0.206	0.472	<b>0.569</b>			
PI	0.229	0.249	0.296	<b>0.628</b>		
TC	0.453	0.394	0.444	0.336	<b>0.734</b>	
TS	0.274	0.340	0.255	0.272	0.449	<b>0.695</b>

**Composite Reliability**

In this study, the researchers utilized composite reliability as a measure to evaluate the reliability of the structural equation model (Awang et al., 2018; Awang, 2015; Hair et al., 2014). According to Awang (2015) and Hair et al., (2014), a composite reliability estimates of 0.7 or higher is indicative of a degree of dependability that is thought appropriate. On the other hand, a score ranging between 0.6 and 0.7 is considered acceptable. The finding demonstrates that the composite reliability of all constructs surpassed the threshold of 0.6, indicating satisfactory internal consistency, as depicted in Table 9. Therefore, it indicated that composite reliability had been attained.

Table 9

*Composite Reliability*

Construct	CR (> .6)
Performance Expectancy (PE)	0.895
Effort Expectancy (EE)	0.899
Social Influence (SI)	0.841
Personal Innovativeness (PI)	0.870
Task Characteristics (TC)	0.917
Technology Characteristics (TS)	0.901

**Normality Assessment**

Finally, the normality distribution of all the items that were utilized in this study to measure the construct was further investigated. In this study, the skewness value for each item should be remain constant with respect to normality (Asnawi et al., 2019; Awang, 2015; Hair et al., 2014). Values of skewness and kurtosis falling within the range of -1.5 to 1.5 are deemed acceptable, suggesting that the distribution does not deviate significantly from the normality, as illustrated in Table 10. Hence, it was revealed that the data distribution fulfilled the normality distribution requirement.

Table 10

*Normality Results*

Codes	Skewness	Codes	Kurtosis
TS5	-0.815	TS5	0.574
TS4	-0.720	TS4	0.366
TS2	-0.758	TS2	0.353
TS1	-0.797	TS1	0.438
PI5	-0.708	PI5	0.239
PI3	-0.627	PI3	0.141
PI2	-0.428	PI2	-0.570
PI1	-0.760	PI1	0.434
TC7	-0.795	TC7	0.548
TC6	-0.832	TC6	0.687
TC5	-0.779	TC5	0.503
TC2	-0.789	TC2	0.543
SI4	-0.056	SI4	-1.237
SI3	-0.143	SI3	-1.173
SI2	-0.121	SI2	-0.519
SI1	-0.050	SI1	-0.823
EE5	-0.742	EE5	0.322
EE3	-0.798	EE3	0.529
EE2	-0.977	EE2	0.965
EE1	-1.026	EE1	1.075
PE6	-0.622	PE6	-0.100
PE5	-0.736	PE5	0.172
PE4	-0.698	PE4	0.251
PE1	-0.681	PE1	0.273

**Conclusion**

The present study established a theoretical framework for identifying and evaluating six dimensions related to e-learning antecedents through the utilization of exploratory factor analysis (EFA) and confirmatory factor analysis (CFA) procedures. The finding of EFA indicate that the presence of six factors related to the e-learning antecedents. These factors were assessed using a set of 32 items, which were found to be suitable for this study based on the results of the Bartlett test of sphericity, which showed high significance. Additionally, the Kaiser-Meyer-Olkin (KMO) measure of sampling adequacy yielded an excellent value (above 0.6), and all factor loadings exceeded the minimum threshold of 0.6, indicating their strong relationship with the underlying factors. Lastly the Cronbach's Alpha surpassed the recommended threshold of 0.6, indicating high internal consistency of the items. Thus, it can be concluded that the validated instrument utilized in this investigation demonstrates consistency as well as stability across the entire samples (Hasim et al., 2023; Hasim et al., 2022). Then, the finding from CFA confirmed that only 24 items of e-learning antecedents were successfully fulfilling the standards needed for convergent validity, construct validity, and discriminant validity. The results from the EFA and CFA have proven that the extraction of six dimensions of e-learning antecedents is reliable for measuring e-learning antecedents in the context of higher educational institutions (HEIs) in Malaysia, and it is advisable to

employ this approach and conducive for a large-scale survey in the future research endeavors. On other hand, the results demonstrate that this instrument is appropriate to be used in the field of information systems, particularly in e-learning systems. Furthermore, it is recommended that the future research in the discipline of e-learning to measure a variety of items and a greater number of questions that can explain many aspects of the construct e-learning antecedents. Moreover, the findings of this inquiry can be extended by using this instrument to other domains of knowledge and putting it on its pace with other populations as well as diverse industries.

### Implications and Future Research

As this study focused on Malaysian technical university network (MTUN) students, then it is encouraged to implement this instrument and examine the results at other public and private institutions in Malaysia, or even in other countries. Lastly, it recommends for future research to employ an alternative analysis tool to examine the instruments utilized in this study and make comparisons with the conclusions that were drawn.

### References

- Abbad, M. M. (2021). Using the UTAUT model to understand students' usage of e-learning systems in developing countries. *Education and Information Technologies*, 26(6), 7205-7224. <https://doi.org/10.1007/s10639-021-10573-5>
- Afolabi, O., & Uhomoibhi, J. (2015). E-learning implementation in higher education: aspects of infrastructure development challenges and students learning approaches. *Nineteenth International Conference on Software Process Improvement Research, Education and Training*, 1(1), 83-94. <http://shorturl.at/btwT9>
- Alkaws, G., Ali, N. A., & Baashar, Y. (2021). The Moderating Role of Personal Innovativeness and Users Experience in Accepting the Smart Meter Technology. *Applied Sciences*, 11(8), 3297. <http://dx.doi.org/10.3390/app11083297>
- Al-Rahmi, W. M., Alias, N., Othman, M. S., Alzahrani, A. I., Alfarraj, O., Saged, A. A., & Rahman, N. S. A. (2018). Use of e-learning by university students in Malaysian higher educational institutions: A case in Universiti Teknologi Malaysia. *IEEE Access*, 6, 14268-14276. <https://doi.org/10.1109/ACCESS.2018.2802325>
- Al-Rahmi, W. M., Othman, M. S., & Yusuf, L. M. (2015). The effectiveness of using e-learning in Malaysian higher education: A case study Universiti Teknologi Malaysia. *Mediterranean Journal of Social Sciences*, 6(5), 625-625. <http://dx.doi.org/10.5901/mjss.2015.v6n5s2p625>
- Anthony, B., Kamaludin, A., Romli, A., Raffei, A. F. M., Nincarean, A., L Eh Phon, D., & Baba, S. (2019). Exploring the role of blended learning for teaching and learning effectiveness in institutions of higher learning: An empirical investigation. *Education and Information Technologies*, 24(6), 3433-3466. <https://doi.org/10.1007/s10639-019-09941-z>
- Anuar, N., Muhammad, A. M., & Awang, Z. (2023). Development and Validation of Critical Reading Intention Scale (CRIS) for University Students using Exploratory and Confirmatory Factor Analysis. *Asian Journal of University Education*, 19(1), 39-52. <https://doi.org/10.24191/ajue.v19i1.21231>
- Asnawi, A. A., Awang, Z., Afthanorhan, A., Mohamad, M., & Karim, F. (2019). The influence of hospital image and service quality on patients' satisfaction and loyalty. *Management Science Letters*, 9(6), 911-920. <http://dx.doi.org/10.5267/j.msl.2019.2.011>

- Awang, Z. (2012). *Research Methodology and Data Analysis*. Malaysia: Penerbit Universiti Teknologi MARA Press.
- Awang, Z. (2015). *SEM Made Simple: A gentle approach to learning structural equation modeling*. Malaysia: MPWS Rich Resources.
- Awang, Z., Lim, S. H., & Zainudin, N. (2018). *Pendekatan Mudah SEM - Structural equation modeling*. Malaysia: MPWS Rich Resources
- Baistaman, J., Awang, Z., Afthanorhan, A., & Abdul Rahim, M. Z. (2020). Developing and validating the measurement model for financial literacy construct using confirmatory factor analysis. *Humanities and Social Science Review*, 8(2), 413-422. <http://dx.doi.org/10.18510/hssr.2020.8247>
- Bere, A. (2018). Applying An Extended Task-Technology Fit for Establishing Determinants of Mobile Learning: An Instant Messaging Initiative. *Journal of Information Systems Education*, 29(4), 239-252. <https://aisel.aisnet.org/jise/vol29/iss4/4>
- Bouranta, N., Chitiris, L. & Paravantis, J. (2009). The Relationship Between Internal and External Service Quality. *International Journal of Contemporary Hospitality Management*, 21(3), 275-293. <http://dx.doi.org/10.1108/09596110910948297>
- Brown, T. A. (2006). *Confirmatory factor analysis for applied research*. New York City: The Guilford Press.
- Buabeng-Andoh, C., & Baah, C. (2020). Pre-Service Teachers' Intention to Use Learning Management System: An Integration of UTAUT and TAM. *Interactive Technology and Smart Education*, 17(4), 455-474. <http://dx.doi.org/10.1108/itse-02-2020-0028>
- Choudhury, S., & Pattnaik, S. (2020). Emerging themes in e-learning: A review from the stakeholders' perspective. *Computers & Education*, 144, 103657. <https://doi.org/10.1016/j.compedu.2019.103657>
- Ehido, A., Awang, Z., Halim, B.A., Ibeabuchi, C. (2020). Developing items for measuring quality of work life among Malaysian academics: An exploratory factor analysis procedure. *Humanities and Social Sciences Reviews*, 8(3), 1295-1309. <http://dx.doi.org/10.18510/hssr.2020.83132>
- El-Sabagh, H. A. (2021). Adaptive e-learning environment based on learning styles and its impact on development students' engagement. *International Journal of Educational Technology in Higher Education*, 18(1), 1-24. <https://doi.org/10.1186/s41239-021-00289-4>
- Finstad, K. (2010). Response Interpolation and Scale Sensitivity: Evidence Against 5-Point Scales. *Journal of Usability Studies*, 5(3), 104-110. <https://dl.acm.org/doi/10.5555/2835434.2835437>
- Fornell, C., & Larcker, D. F. (1981). Evaluating structural equation models with unobservable variables and measurement error. *Journal of Marketing Research*, 18(1), 39-50. <https://doi.org/10.1177/002224378101800104>
- Ghani, M. N. H., Abdullah, S., Ismail, M. K., Ahmad, N., Affandi, S., Mohamad Azmin, N. A., & Abdul Manaf, S. M. (2022). An Exploratory Factor Analysis on the Open and Distance Learning among University Students during the COVID-19 Pandemic in Malaysia. *Asian Journal of University Education*, 18(3), 724-734. <https://doi.org/10.24191/ajue.v18i3.18956>
- Goodhue, D. L., & Thompson, R. L. (1995). Task-Technology Fit and Individual Performance. *MIS quarterly*, 19(2), 213-236. <https://doi.org/10.2307/249689>



- Hair, J. F., Black, W. C., Babin, B. J., & Anderson, R. E. (2014). *Multivariate data analysis* (7th ed.). Harlow: Pearson Education Limited.
- Hasim, M. A., Jabar, J., & Murad, A. M. (2019). A preliminary research on consumer acceptance in nanofood towards purchase intention: A pilot research. *International Journal of Recent Technology and Engineering*, 8(2S3), 352-356. <https://doi.org/10.35940/ijrte.B1060.0782S319>
- Hasim, M. A., Jabar, J., Murad, M. A., & Ali, N. N., (2020). An Exploratory Factor Analysis on Adoption Factors of P3 Sweetener. *Test Engineering and Management*, 82, 9647-9654. <http://testmagazine.biz/index.php/testmagazine/article/view/2375/2110>
- Hasim, M. A., Jabar, J., Sufian, A., & Ibrahim, N. F. (2022). Validating the Component of E-learning Antecedents, Digital Readiness and Usage Behavior towards E-learning Performance: A Pilot Study. *International Journal of Learning, Teaching and Educational Research*, 21(10), 178-194. <https://doi.org/10.26803/ijlter.21.10.9>
- Hasim, M. A., Jabar, J., Sufian, A., Ibrahim, N. F., & Abdul Khalid, F. (2023). Employing fuzzy Delphi techniques to validate the components and contents of e-learning antecedents and usage behavior towards e-learning performance. *European Journal of Educational Research*, 12(1), 467-480. <https://doi.org/10.12973/eu-jer.12.1.467>
- Ho, N. T. T., Sivapalan, S., Pham, H. H., Nguyen, L. T. M., Van Pham, A. T., & Dinh, H. V. (2020). Students' adoption of e-learning in emergency situation: the case of a Vietnamese university during COVID-19. *Interactive Technology and Smart Education*, 18(2), 246-269. <http://dx.doi.org/10.1108/ITSE-08-2020-0164>
- Holmes, W., Nguyen, Q., Zhang, J., Mavrikis, M., & Rienties, B. (2019). Learning analytics for learning design in online distance learning. *Distance Education*, 40(3), 309-329. <https://doi.org/10.1080/01587919.2019.1637716>
- Hoque, A. S. M., Siddiqui, B. A., Awang, Z. B., Baharu, S. M. A. (2018). Exploratory factor analysis of entrepreneurial orientation in the context of Bangladesh small and medium enterprises (SMES). *European Journal of Management and Marketing Studies*, 3(2), 81-94. <https://oapub.org/soc/index.php/EJMMS/article/view/384>
- Hu, L. T., & Bentler, P. M. (1999). Cutoff criteria for fit indexes in covariance structure analysis: Conventional criteria versus new alternatives. *Structural Equation Modeling: A Multidisciplinary Journal*, 6(1), 1-55. <https://doi.org/10.1080/10705519909540118>
- Johns, R. (2010). Survey Question Bank: Methods Fact Sheet. *Survey Resources Network*, 6, 1-102. [https://dam.ukdataservice.ac.uk/media/262829/discover\\_likertfactsheet.pdf](https://dam.ukdataservice.ac.uk/media/262829/discover_likertfactsheet.pdf)
- Kim, H. J., Hong, A. J., & Song, H. D. (2019). The roles of academic engagement and digital readiness in students' achievements in university E-learning environments. *International Journal of Educational Technology in Higher Education*, 16(1), 21. <https://doi.org/10.1186/s41239-019-0152-3>
- Kline, R. B. (2011). *Principles and practice of structural equation modeling* (3rd ed.). New York City: Guilford Press.
- Knekta, E., Runyon, C., & Eddy, S. (2019). One size doesn't fit all: Using factor analysis to gather validity evidence when using surveys in your research. *CBE—Life Sciences Education*, 18(1), 1-17. <https://doi.org/10.1187%2Fcbe.18-04-0064>
- Krejcie, R. V., & Morgan, D. W. (1970). Determining sample size for research activities. *Educational and Psychological Measurement*, 30(3), 607-610. <https://doi.org/10.1177/001316447003000308>

- Mohamad, M., Mohammad, M., Mat Ali, N. A., & Awang, Z. (2018). The impact of life satisfaction on substance abuse: Delinquency as a mediator. *International Journal of Adolescence and Youth*, 23(1), 25–35. <http://doi.org/10.1080/02673843.2016.1267021>
- Priatna, T., Maylawati, D., Sugilar, H., & Ramdhani, M. (2020). Key success factors of e-learning implementation in higher education. *International Journal of Emerging Technologies in Learning*, 15(17), 101-114. <https://doi.org/10.3991/ijet.v15i17.14293>
- Samsudeen, S. N., & Mohamed, R. (2019). University Students' Intention to Use E-learning Systems: A Study of Higher Educational Institutions in Sri Lanka. *Interactive Technology and Smart Education*, 6(3), 219-238. <https://doi.org/10.1108/ITSE-11-2018-0092>
- Saripudin, S., Sumarto, S., Juanda, E. A., Abdullah, A. G., & Ana, A. (2020). Vocational school teachers' perceptions of e-learning during covid-19. *Journal of Engineering Education Transformations*, 34, 7-13. <http://dx.doi.org/10.16920/jeet/2020/v34i0/157844>
- Sarkam, N. A., Nasrudin, N. H., Razi, N. F. M., & Junid, R. A. (2022). Student Readiness Factors for Online Distance Learning among Malaysian Public Universities during COVID-19: A Conceptual Model. *Asian Journal of University Education*, 18(4), 1048-1061. <https://doi.org/10.24191/ajue.v18i4.20014>.
- Sekaran, U., & Bougie, R. 2016. *Research methods for business: A skill building approach* (7th ed.). Wiley.
- Shahmoradi, L., Changizi, V., Mehraeen, E., Bashiri, A., Jannat, B., & Hosseini, M. (2018). The challenges of E-learning system: Higher educational institutions perspective. *Journal of education and health promotion*, 7, 116. [https://doi.org/10.4103%2Fjehp.jehp\\_39\\_18](https://doi.org/10.4103%2Fjehp.jehp_39_18)
- Shau, T. V. (2017). The confirmatory factor analysis (CFA) of preschool management model in Sarawak. *International Journal of Academic Research in Business and Social Sciences*, 7(6), 221-231. <https://ideas.repec.org/a/hur/ijarbs/v7y2017i6p221-231.html>
- Shkeer, A. S., & Awang, Z. (2019). Exploring items for measuring marketing information system construct: An exploratory factor analysis. *International Review of Management and Marketing*, 9(6), 87-97. <http://dx.doi.org/10.32479/irmm.8622>
- Shrestha, N. (2021). Factor analysis as a tool for survey analysis. *American Journal of Applied Mathematics and Statistics*, 9(1), pp.4-11. <https://10.12691/ajams-9-1-2>
- Taber, K. S. (2018). The use of Cronbach's alpha when developing and reporting research instruments in science education. *Research in Science Education*, 48(6), 1273– 1296. <https://doi.org/10.1007/s11165-016-9602-2>
- Taherdoost, H. (2019). What Is the Best Response Scale for Survey and Questionnaire Design; Review of Different Lengths of Rating Scale/Attitude Scale/Likert Scale. *International Journal of Academic Research in Management*, 8(1), 1-10. [https://papers.ssrn.com/sol3/papers.cfm?abstract\\_id=3588604](https://papers.ssrn.com/sol3/papers.cfm?abstract_id=3588604)
- Tan, P. J. B. (2013). Applying the UTAUT to Understand Factors Affecting the Use of English E-learning Websites in Taiwan. *Sage Open*, 3(4), 1-12. <https://doi.org/10.1177/2158244013503837>
- Twum, K. K., Ofori, D., Keney, G., & Korang-Yeboah, B. (2021). Using The UTAUT, Personal Innovativeness and Perceived Financial Cost to Examine Student's Intention to Use E-learning. *Journal of Science and Technology Policy Management*, 2(1), 2053-4620. <https://pesquisa.bvsalud.org/global-literature-on-novel-coronavirus-2019-ncov/resource/pt/covidwho-1367133>

- Ugur, N. G., & Turan, A. H. (2018). E-learning adoption of academicians: a proposal for an extended model. *Behaviour & Information Technology*, 37(4), 393-405. <https://doi.org/10.1080/0144929X.2018.1437219>
- Vavasseur, A., Muscari, F., Meyrignac, O., Nodot, M., Dedouit, F., Revel-Mouroz, P., Dercle, L., Rozenblum, L., Wang, L., Maulat, C., Rousseau, H., Otal, P., Dercle, L., & Mokrane, F. Z. (2020). Blended learning of radiology improves medical students' performance, satisfaction, and engagement. *Insights into Imaging*, 11, 1– 12. <https://doi.org/10.1186%2Fs13244-020-00865-8>
- Venkatesh, V., Morris, M. G., Davis, G. B., & Davis, F. D. (2003). User Acceptance of Information Technology: Toward A Unified View. *MIS Q.* 27, 425–478. <https://doi.org/10.2307/30036540>
- Wagiran, W., Suharjana, S., Nurtanto, M., & Mutohari, F. (2022). Determining the e-learning readiness of higher education students: A study during the COVID-19 pandemic. *Heliyon*, 8(10),11160. <https://doi.org/10.1016/j.heliyon.2022.e11160>
- Wali, A., & Popal, A. (2020). The emerging issues and impacts of technology in classroom learning. *International Journal of Emerging Technologies in Learning*, 15(15), 237-245. <https://doi.org/10.3991/ijet.v15i15.14175>
- Wijesundara, T. R., & Xixiang, S. (2018). Social Networking Sites Acceptance: The Role of Personal Innovativeness in Information Technology. *International Journal of Business and Management*, 13(8), 75-85. <https://doi.org/10.5539/ijbm.v13n8p75>
- Wong, K. T., Hwang, G. J., Choo Goh, P. S., & Mohd Arrif, S. K. (2020). Effects of blended learning pedagogical practices on students' motivation and autonomy for the teaching of short stories in upper secondary English. *Interactive Learning Environments*, 28(4), 512-525. <https://doi.org/10.1080/10494820.2018.1542318>
- Yahaya, T., Idris, K., Suandi, T., & Ismail, I. (2018). Adapting instruments and modifying statements: The confirmation method for the inventory and model for information sharing behavior using social media. *Management Science Letters*, 8(5), 271-282. <http://dx.doi.org/10.5267/j.msl.2018.4.021>
- Yusof, Y., Awang, Z., Jusoff, K., & Ibrahim, Y. (2017). The influence of green practices by non-green hotels on customer satisfaction and loyalty in hotel and tourism industry. *International Journal of Green Economics*, 11(1), 1–14. <http://doi.org/10.1504/IJGE.2017.082716>