

Work Ethics' Impact on Counterproductive Work Behaviour in Institutes of Higher Education

Norashikin Misnan^a, Sharizan Sharkawi^b, & Zuhaina Mustapa^c

^aFaculty of Business and Accountancy, Universiti Poly-Tech Malaysia, Kuala Lumpur, Malaysia, ^bFaculty of Business Management, Universiti Teknologi Mara, Selangor, Malaysia,

^cFaculty of Business Management, Universiti Teknologi Mara, Selangor, Malaysia

Email: norashikin_m@uptm.edu.my, sharizan_sharkawi@uitm.edu.my,
zuhaina528@uitm.edu.my

To Link this Article: <http://dx.doi.org/10.6007/IJARBSS/v14-i6/21663>

DOI:10.6007/IJARBSS/v14-i6/21663

Published Date: 18 June 2024

Abstract

Counterproductive work behaviour (CWB) projected would negatively impact both individuals and organizations in some ways. The ideas of CWB harm the performance of the institution which develops stress-related issues, low morale and lost work time. To estimate the likelihood of reducing counterproductive work behaviour (CWB) among employees, this concept paper aims to examine work ethics and CWB with a prediction that strong work ethics are seen to make people less inclined to participate in CWB. The main objective of this study is to investigate how work ethic components are affecting CWB. A theoretical structure was created using theoretical models to identify the elements of work ethics that are expected to reduce CWB such as ethics code, regulations, independence, hard work and work goals. The research will be conducted in selected institutes of higher education which discover both academic and non-academic. A questionnaire will be used as the data gathering tool in this quantitative study and the analysis uses IBM Statistical Package for Social Sciences (SPSS). The expected findings after the hypotheses have been tested are the components of work ethics able to reduce CWB among employees as predicted. Future research should involve additional variables and be conducted in different areas of sectors to allow the extending level of analysis specifically in understanding human behaviour.

Keywords: Counterproductive Work Behaviour, Ethics Code, Regulations, Independence, Hard Work and Work Goals

Introduction

Behaviour is categorised as either positive or negative in the context of work. The desired behaviour is known as good behaviour also referred to as organizational citizenship behaviour (OCB) especially when it comes to increasing worker productivity and organizational performance. Furthermore, OCB is described as discretionary activity that increases the overall effectiveness of the organisation but is not immediately or overtly recognised by the

official incentive system (Anwar et al., 2020). Further, OCB refers to an employee's civic activity in the workplace that goes beyond employment requirements (Eungoo & Hwang, 2023). Generally, to promote effective work and higher productivity, an organization requires a positive attitude from all employees (Robbins & Judge, 2009). Because of this, the majority of businesses anticipate that their staff will be more productive while abstaining from any unfavourable behaviour that could interfere with the seamless operation of the company.

In contrast, the subject of this concept paper is counterproductive work behaviour, or negative behaviour (CWB). Any action taken by members of an organization that violates the law or the organization's norms and regulations is known as the CWB (Sackett and Devore, 2001). According to Robinson and Bennett (1995), CWB terms refer to workplace deviant behaviour which is used in sociological research. Some scholars refer to CWB as a voluntary collection of acts that may breach organizational formality inside the workplace Choi & Park, 2015; Fida et.al., 2015). Additionally, Robinson and Bennett (1995) distinguished between CWB interacting with the organization (CWB-O) and CWB interacting with individuals (CWB-I). The (CWB-O) include theft, fraud, sabotage, purposefully working slowly, and wasting resources, while (CWB-I) such as verbal abuse and hostility. Furthermore, CWB are dysfunctional behaviours that affect people individually as well as the organisations where they operate. In addition to breaking organizational policies, dysfunctional behaviour hurts output and profitability by having a detrimental impact on staff members (Tahir et al., 2018). There are various reasons CWB issues have been highlighted as such cost and productivity issues. Aligned with the statement, CWB costs organizations personnel and productivity, increases turnover and job stress, and generates a generally bad workplace climate that results in a lack of energy, excitement, and optimum production from employees (Mount & Johnson, 2006). Additionally, CWB significantly affects a business's profitability, exceeding other HR or organizational behaviour challenges as well, with estimates ranging from billions of dollars to billions of dollars (Bennett et al., 2018). According to recent studies, over 90% of employees admit to participating in workplace deviance or CWB (Bennett et al., 2018). Five categories; verbal abuse, production deviance, sabotage, theft and withdrawal are used to characterise CWB (Spector et al., 2006).

CWB in higher education does not entail confronting coworkers or disagreeing with a leader's stance. Rather, it may lead to a deteriorated environment at school, interfere with administrative tasks, and impede the process of teaching and learning. According to Robinson and Bennett (1995), CWB in higher education solely impacts political and production deviance, not the economic side. Delaying the commencement of the class, staying late at work without authorization, taking unscheduled absences and accelerating the learning timetable are examples of CWB at higher education within the context of production deviance. In addition, Kidwell et al (2018) argue teaching slowly, working sluggishly and engaging in other associated behaviours can also be included as CWB activity.

While, political deviance happens in higher education such as promoted depending on personal interests rather than performance reviews (Sarwar & Alam, 2010). Emerging CWB issues in institutes of higher education also due to educational leaders have not paid much attention (Ibrahim & Iqbal, 2015). According to Hidayah et al (2023) higher education establishments demand more independence and a high level of accountability from their staff members which isn't the case for workers in corporate or factory settings, where ties to coworkers are tight and organizational structure plays a significant role. Among issues regarding CWB at some public and private universities in Pakistan, is the wrong ethical system

or ethical climate determined as the main factor influencing deviant behaviours (Obalade & Arogundade, 2019).

In addition, deviant behaviour engaged among staff members both academic and non-academic at institutes of higher education such as extortion of money, irregularities in student conduct, falsifying student grades and staff records to make money, blatant disrespect for established authority and admission fraud, and impersonation (Egidi et al., 2017). Chirasha & Mahapa (2012) conducted study relating CWB among employees in state universities in Nigeria found several CWB trends which is 15% of the participants reported that they had taken extended breaks, while 10% of the respondents received a warning for purposely working slowly, printing their items and other workplace infractions.

For instance, a recent study on work ethics and workplace deviance found that when workers are in an ethical environment, they are less likely to act in a deviant manner in other environments (Soomro et al., 2020). According to Abdullah and Halim (2016), work ethic appears to be the most essential aspect in an organization's development and influencing the CWB in the public sector. Nonetheless, there are conflicting or inconsistent findings about how ethical employment affects employees' aberrant behaviour (Hsieh & Wang, 2016). Furthermore, most work ethics and CWB studies carried out in Malaysia were in the public sector and involved a small number of researchers who focused on particular aspects of work ethic (Abdullah and Halim, 2016; Yahya et al., 2011; Sharif, 2000; Nazaar et al., 1997).

As a result, research on work ethics and CWB concerns in institutes of higher education in Malaysia are under-researched based on the gaps in local research. Thus, the purpose of this concept paper is to examine the connection between CWB and work ethics further, assuming the components of work ethics, such as ethical codes, rules or regulations, independence, hard work and work goals or objectives might lessen the incidence of CWB among members in institutes of higher education.

Literature Review

Self-Regulation Theory (SRT) and other aspects of work ethics are the main topics of this study. It is believed that a variety of work ethics-related components, such as ethical codes, rules or regulations, independence, hard work and work goals or objectives may lessen workers' counterproductive work behaviour (CWB). These will be covered in the following subsections.

Self-regulation theory (SRT)

Bandura (1991) defined self-regulation theory (SRT) as an ongoing, active process in which an individual engages in three activities: (1) observing one's behaviour, including influences and consequences; (2) evaluating one's behaviour in light of one's standards (goal); and (3) reacting to one's behaviour, including thoughts and feelings regarding the behaviour. It was defined as a theory that outlines the steps and elements involved in choosing what to feel, think, say, and do. When it comes to making informed judgements, it is particularly crucial. The theory emphasises self-regulation to ascertain a person's capacity to influence or control their impulses to make sense of their circumstances, as referenced in Bandura (1991) as well. Besides, Oettingen (1999) has proposed that one of the self-regulating modes is to be reasonable and unaffected by anticipated chances of success, such as expectations, where people could try too hard (when hopes are high) or too little (when expectations are low) to achieve their goals. Aligned with the development of the framework, the self – regulation theory represents the situation where people use a designated work ethic at the workplace

and then move toward action or behaviour as the outcome. There are arguments about the connections between self-regulation and behaviour as the outcomes including criminality, job performance, and human behaviour (Baumeister et al., 1994). Self-regulation theory not only the control of actions but also the ideas and emotions (Sheppes et al., 2015).

It can also be interpreted as an all-encompassing argument, including a broad range of goal-relevant activities such as changing one's ideas, feelings, and behaviours and exerting conscious self-control (Fujita, 2011). Positive psychological well-being and behaviours that promote health are fostered by efficient self-regulation (Baumann et al., 2005). The ability to survive and thrive in a range of situations is one of humanity's adaptive advantages. Therefore, this perspective maintains that the ability to control one's thoughts, attention, emotions, behaviours, and reactions is a crucial component of self-regulation (Gestsdottir & Lerner, 2008). As the researcher persists in investigating the correlation between work ethic and counterproductive work behaviour (CWB) inside the workplace, this theory appears to be pertinent.

Counterproductive Work Behaviour (CWB)

The occurrence of such behaviours in the workplace is seen as damaging to the organization's well-being (Bennett & Robinson, 2000). Regardless, employee deviation is regarded as a negative factor in organisational effectiveness, and concerns around workplace misbehaviour have received significant media attention. Five categories were used by Spector and Fox (2005) to categorize CWB; production deviance, abuse, theft, sabotage, and withdrawal. There are various common and widely quoted CWB definitions, the majority of which are provided by recognised experts in the field. One of the early definitions of CWB is by (Wheeler, 1976), who differentiates it from minor to major. Furthermore, it asserted that it can distinguish between deviants directed against organisations and individuals. Due to these two differences, four deviance typologies or quadrants known as CWB individual or people (CWB-I) and CWB organization (CWB-O) were created and each quadrant was classified as mild to major CWB (Robinson & Bennett, 1995). The four components are characterized as property deviance, production deviance, personal aggressiveness, and political deviance, and they have received a lot of attention in academia.

Work Ethics

Aside from financial resources, work ethics might influence someone to conduct or not commit a crime (Komari & Djafar, 2013). Work ethics are crucial in today's workplace since employee behaviour greatly affects an organization's capacity to compete in the global economy (Valentine & Barnett, 2013). The foundation for ethical behaviour among employees and a means of averting issues that could be harmful to the company and its members is work ethics (Yousef, 2001). Employees who work in organizations that prioritise the development of work ethics pertinent to their concerns will behave ethically (Valentine & Barnett, 2013). Work ethics are cultural norms founded on the idea that employment has intrinsic value for people and that people should take full responsibility for their jobs (Nizam et al., 2016).

There are a few phrases that are used interchangeably to describe work ethic such as ethical work climate which describes an environment at work that encourages moral behaviour (Schminke et al., 2007). According to Sapada et al (2017), work ethics are normative norms that consist of a set of moral guidelines and rules that direct employees in carrying out their professional responsibilities throughout the company. It also covers the moral principles and

ideals that guide an individual's or group's behaviour. Additionally, it describes also as an ethical work environment that is built on diligence, integrity, consideration, and adherence to rules and guidelines. Businesses without an ethical work environment confront a variety of issues, both personal and professional, including deviant behaviour by employees, poor performance, low productivity, and employee discontent (Farouk & Jabeen, 2018). Leaders must uphold the organization's core values, to ensure that an ethical environment is being fostered (Soomro et al., 2020).

Numerous indicators have been established in the literature to be used in measuring work ethics. The indicators include employee evaluation and promotion Long et al (2021); employees' productivity (Runtu et al., 2019); job performance Akinbode and Falola (2015); work satisfaction and organizational commitment (Komari & Djafar, 2013); human ethics, business policies and procedures, legal frameworks, codes of conduct Elçi & Alpan (2009); leadership Hitt (1990) and many else. According to Yunus et al (2011) stated that a decline in work ethics has been associated with an increase in deviant behaviours in the workplace.

Work Ethics in Institutes of Higher Education (IHE)

Recent modifications to the operating system and work environment have brought attention to the need for work ethics in higher education institutions. Higher education like universities, has seen an increase in unethical behaviour from both academic and non-academic sources (Ehrich et al., 2012). Among the unethical behaviours noted by research participants were academic dishonesty, improper behaviour towards staff and students, and inconsistencies with the organization's norms and procedures (Ehrich et al., 2012). Besides that, ethics in the university context highlighted the most unethical behaviours include staff and student plagiarism, several types of cheating, power abuse and taking presents or cash in exchange for marks (Ashford & Davis, 2006). Study conducted by Zvavahera et al (2021), recommended that strong work ethics which align with optimal HR procedures may improve workplace relationships and productivity.

Good workplace ethics promote a happy atmosphere and guarantee a motivated and productive workforce, which reduces the likelihood of labour conflicts that could be expensive for the organization as well as the employee (Jayabalan, 2013). Ethics plays a significant role in higher education institutions' overall plans for creating an ethical culture within their institutes (Preston et al., 2002). Despite their tremendous relevance as a fundamental component of corporate culture, organizational ethics and the execution of ethical initiatives at all organizational levels are still often overlooked or even neglected, not only in the business sector but also in the educational system (Juras et al., 2022).

In addition, the result of the study obtained ethical policies and initiatives alone may not be very effective in influencing staff members' ethical behaviour; however, when combined with high ethical behaviour that has been demonstrated at the organizational level, these policies and initiatives have a positive effect on university staff members' ethical behaviour. According to Prisacariu & Shah (2016), moral principles and ethics are characteristics of a top-notch institution since they provide ethical norms for research, teaching, and other endeavours through corporate and academic governance frameworks.

Rather than the actions of administrative personnel, the majority of how ethics are viewed in higher education is determined by the behaviour of leaders, instructors, and students as well (Juras et al., 2022). Higher education institutions' moral principles and ethics are evaluated by looking at how administrators and staff conduct themselves as well as how students behave as a result of their influence (Mirshekary & Lawrence, 2009). Most researchers are

increasingly paying greater attention to previously disregarded studies on organizational ethics, ethical issues and behaviours in higher education since these themes have gained significance and are viewed as persistent problems (Rothman, 2017; Jamil et al., 2019).

CWB in Institutes of Higher Education (IHE)

Even in institutes of higher education, the issue of CWB or unethical behaviour in the workplace persists and the issues surrounding higher education are gaining attention and are becoming a frequent subject of discussion amongst a variety of people (Ishak et al., 2019). Concerns about organizational wrongdoing have drawn the attention of numerous researchers as well as in institutes of higher education with its constituents; academicians, administrators, and students become enmeshed in the problem which the scandals can involve fraud, bribery, and corruption (Ishak et al., 2019).

In addition, there is a claim that given the challenges and advancements in the sector, ethical and moral principles should be closely linked to the quality of higher education (Prisacariu & Shah, 2016). Study by McCornac (2015) which surveys among academicians, administrators and students demonstrate how deeply ingrained institutionalized corruption is in Vietnam's higher education sector. An act that deviates from what is deemed morally appropriate is referred to as unethical behaviour and higher education institutions may experience this type of attitude from their administrative personnel, lecturers, and students (Ishak et al., 2019).

According to De Russy (2003), unethical behaviour in institutes of higher education including lecturers frequently arriving late for class, using harsh language with students, misusing research grants, plagiarising, having affairs with students, refusing to teach or do research, and struggling to complete assigned administrative tasks. Regarding the administrative personnel, examples of unethical activity include corruption, utilising university resources for personal benefit, obtaining goods and services illegally, and abusing authority for material or private advantage (Heyneman, 2015). Table 1 illustrates how unethical behaviours and the ethical infrastructure in institutes of higher education (IHE) are perceived.

Table 1

The components of ethical culture and unethical behaviours in Universities

Ideal components of ethical culture	The most prevalent unethical behaviours
Mission statement	Purchasing goods and services illegally
Honour code for students	fraudulent graduation, grading, and admissions
Codes of conduct for students, faculty and administrators	Research plagiarism, favouritism towards members, biased grading, and abuse of authority are examples of professional misconduct
Adjudication procedures and reported ethical violations	Fraud involving the utilisation of university property and tax payments

Source: Adapted from Ishak et al (2019)

Work ethics and counterproductive work behaviour (CWB)

One of the elements influencing many organizational behaviours is an ethical work environment, which has a significant effect on deviant behaviour. These two items could be related directly or through the mediation of other elements (Mansoara & Armanu, 2021). The principle of a culture of ethics in the workplace gives workers clear direction on appropriate conduct, which reduces role conflict, ambiguity, and stress and, as a consequence, lowers turnover (Mulki et al., 2008). Study by Vardi (2001) claims that a study of employees at a metal manufacturing business revealed a negative correlation between work ethics and undesired employee behaviours, such as drinking at work, utilising personal phone calls, and harassing coworkers sexually.

Based on a previous study by Robinson and Bennett (1995), workers who operate in an unethical environment are more likely to act abnormally. While, according to Andreoli and Lefkowitz (2009), a deficient ethical in the workplace was found to be a predictor of deviance. There is a claim that a company may have a range of problems as a result of an unethical culture, for example is disgruntled workers, poor performance, and low production (Bennett et al., 2018). Work ethics is a very broad notion that includes morals, leisure, and the workplace. Some components of work ethics are covered in this concept paper such following; an ethics code, independence, rules, hard work, and work goals as

Ethics Code

It has been noted that by defining norms for employee ethics, ethical codes offer a clear route to more viable and justifiable organizational activities (Adelstein & Clegg, 2016). Previously, a study by Adelstein & Clegg (2016) they chose Microsoft Corporation as one of the world's most prominent and globally visible organizations to be the focus of its empirical research. Microsoft's code of ethics includes equal prescriptions for employee behaviour and disciplinary actions. According to Paine (2010), an organizational code of ethics can be understood as a tool for controlling and regulating desired employee behaviour, taking corrective action, upholding higher ethical standards, and requiring compliance with performance assessments. An ethics code's purpose is to ensure that a company's code of ethics is well-known and improves the company's reputation (Basu & Palazzo, 2008). An individual's work ethic and level of job satisfaction are believed to be validated by ethics rules (Elçi & Alpan, 2009). Precisely said, a company's code of ethics is the official, documented, and legally-mandated statement of the organization's values for moral behaviour among its employees (Adelstein & Clegg, 2016). Thus, this study proposed the following hypothesis to be tested

H1: Research indicates a negative correlation between the ethics code and counterproductive work behaviour (CWB) among staff in institutes of higher education.

Regulations

Regulations are the guidelines that personnel must adhere to, which they demonstrate by their attitudes (Al-Nashash et al., 2018). Generally speaking, the rules or regulations may reflect the guidelines, or other limitations on how to follow legal requirements, commercial customs, and similar practices (Leite & Leonardi, 1998). The rules should be interpreted as broad declarations about the organization and how its members are expected to carry them out in everyday activities (Leite & Leonardi, 1998). Workplace laws are also employed in the safety industry to encourage workplace safety measures. In addition, to encourage

personnel to practice safety on construction sites, an organization must define its safety principle through safety policies, rules, and regulations (Zulkeflee et al., 2020). Based on the literature, the most successful safety program in developing employees' behaviour includes continuing efforts in updating work procedures and having efficient and effective safety rules and regulations (Hassan et al., 2007). Strict supervisory monitoring must be coupled with efficient safety laws and regulations to guarantee that the safety goals are met and to minimise deviant behaviour at work sites (Zulkeflee et al., 2020). Appropriate regulations are fundamental to producing effective outcomes and the processes for creating regulations are significant, even if not crucial (Thompson, 2011). According to some empirical results in the literature, employees must follow corporate norms, regulations, processes, and policies to support organizational objectives and maintain the organization's viability (Appelbaum et al., 2007). In light of the debate, this study proposed that:

H2: Research indicates a negative correlation between the regulations and counterproductive work behaviour (CWB) among staff in institutes of higher education.

Independence

The ability of a person to act within an organization in their own best interests while considering the extent to which their moral principles lead them is known as independence (Shacklock et al., 2011). The ethical principle-related aspects of independence depend on the employee's moral and personal convictions as well as their preference for upholding their own set of moral standards (Al-Nashash et al., 2018). Workers act on their moral convictions while adhering to established guidelines and individual decisions are made by considering moral standards (Elci & Yagmur, 2019). Within the context of their moral convictions, employees can guide their behaviour in the independence component. Furthermore, personnel base their decisions primarily on their own beliefs, giving precedence to their moral convictions above external forces when making ethical climate decisions (Tokmak, 2020). Previously, in measuring work ethics, independence also has been used as one of the measurements and the result shows high reliability of the independence subscale with having Cronbach alpha of 0.87 (Gwamanda & Mahembe, 2023). As a result, the following hypothesis was put forth for testing in this study:

H3: Research indicates a negative correlation between independence and counterproductive work behaviour (CWB) among staff in institutes of higher education.

Hard Work

An ethical work environment is defined as one that fosters moral behaviour. It also addresses the ethical concepts and precepts that guide a person's or an organization's actions (Soomro et al., 2020). Principles of the organization, such as honesty, diligence, and integrity, are fundamental to establishing ethical standards in the workplace and should never conflict with them (Soomro et al., 2020). Thus, hard work is mostly used as one of the indicators in measuring work ethics or ethical work climate (Ali, 1998; Komari & Djafar, 2013). Furthermore, base their decisions primarily on their own beliefs, giving precedence to their personal moral convictions above external forces when making ethical climate decisions (Al-Nashash et al., 2018). According to Ali (1998), the Islamic work ethic also emphasises that dedication to one's work and hard labour are the keys to success and growth in the workplace. The key to success for both people and organisations is hard work, which fosters a strong

work culture in the workplace (Yunus et al., 2011). This study made the following suggestions based on claims made in the literature:

H4: Research indicates a negative correlation between hard work and counterproductive work behaviour (CWB) among staff in institutes of higher education.

Work Goals

Employees' attitudes towards work that fosters self-esteem have been described as the indicator of work goals utilised in work ethic measurement (Cullen & Victor, 1988). According to Al-Nashash et al (2018), having independence and work goals within work ethics is highly integrated into employee job happiness. The outcome emphasised the significance of work goals while creating work ethics with employees in mind. It also shows how closely independence and ethical work goals are related to job satisfaction among employees (Al-Nashash et al., 2018). The tool used to assess work ethical goals such as; that employees always attempt to improve their efficiency and set their tasks to be fulfilled efficiently. Establishing goals for work is considered a form of work spirituality or belief, which is characterised as a philosophy that fervently upholds the notion that labour is valuable and significant (Amin et al., 2021). The implication of spirituality at work at the individual level is individual's work attitudes and behaviour are motivated, interested, and passionate about doing tasks that have meaning and purpose as a result of this notion (Tayebiniya & Khorasgani, 2018). Prior research has demonstrated a conceptual relationship between workplace spirituality and workplace misbehaviour which they contend that having belief in a job will give employees a moral base that will withstand workplace immorality (Malik & Lenka, 2018). Therefore, the below hypothesis is formulated:

H5: Research indicates a negative correlation between work goals and counterproductive work behaviour (CWB) among staff in institutes of higher education.

Proposed Research Framework

This research aims to reduce counterproductive work behaviour (CWB) by proposing work ethics in five dimensions, as shown in Figure 1.

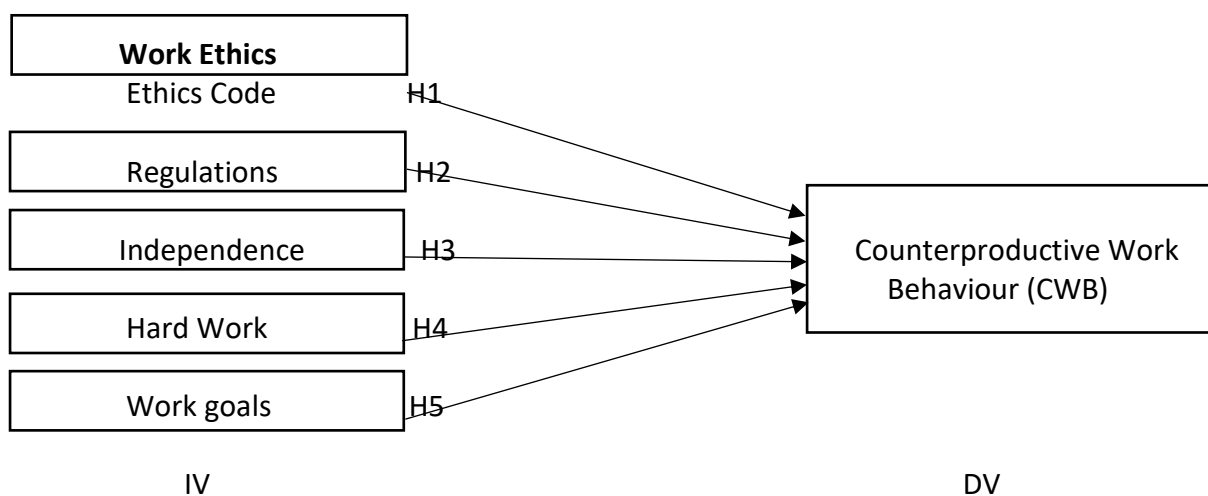

Figure 1: Research Framework

Research Methodology

This study will employ correlational research design and quantitative research methods to analyse the variables that could affect the way this study is conducted. Additionally, the quantitative approach involves a researcher using Google Forms as a platform for data collection to administer surveys or questionnaires to collect information. Then, the respondents who are administrative and academic staff members from selected institutes of higher education that met the requirements established by the researcher will complete the questionnaire. As a result, this study will be carried out at three institutes: A Institute, B Institute, and C Institute and artificial names will be used to protect the secrecy of the three institutes. A five-point Likert scale with the following categories will be used: (1) for highly disagree, (2) for disagree, (3) for neutral, (4) for agree, and (5) for highly agree. Another section of questions will be used; (1) for Never, (2) for once in a while, (3) for some days in a month, (4) for every day and (5) for many times a day.

The unit analysis of this research will be an individual employee who is working in the selected institute of higher education. The 761 personnel across the three institutes that have been chosen will be the population of this study. The researcher then uses this number to calculate sample sizes using the table created by (Krejcie & Morgan, 1970). The table indicates that there are 248 employees in the study's sample. The researcher will utilize IBM Statistical Package for Social Sciences (SPSS) version 28 to carry out this research.

The independent variables (IVs) in this study are the following: independence, regulations, hard work, and work goals; the dependent variable (DV) is counterproductive work behaviour. The variables' items are taken from multiple references by the researcher to develop the questionnaire. The independent variables are based on a total of eighteen items from Al-Nashash et al (2018); Ethics Code (4), Regulations (4), Independence (3), Hard Work (3) and Work Goals (4). Then, Counterproductive work behaviour (CWB) refers to; Fox and (Spector, 2002; Gruys & Sackett, 2003; Akbulut et al., 2016).

Conclusions

The study's conclusion highlights the fundamentals of work ethics that have been highlighted to lower the prevalence of counterproductive work behaviour (CWB) among employees, particularly in higher education institutions. It also emphasizes how these elements are critical in helping organizations minimize the cases of CWB at the workplace. It is expected that enhanced work ethics compliance may reduce the risk of CWB activities. Organizations must address the different components of the workplace that can have a substantial impact on employees and the firm as a whole. Each employee also should be educated and reminded to let them understand the value of a strong work ethic in their allocated responsibilities, habits, and attitudes and the effect of work ethics practices towards employees as individuals and the organization as a whole.

Contribution of the Study

The fresh contribution is expected to make a significant contribution to education as well as other areas. Theoretically, behavioural research will contribute to the conservation of resources hypothesis by giving light on the link between workplace deviance and work ethics. The evaluation of the literature indicates that, as of yet, no local study has looked at the association between all five variables in one study except for substantial studies (Al-Nashash et al., 2018). As a result, the study demonstrates a lack of understanding of the facets of work ethics that encourage the reduction of counterproductive work behaviour (CWB) at work.

Furthermore, the study's codified work ethics or ethical principles are viewed as an initiative and are expected to have a significant influence on the participants' ethical behaviour in higher education institutions.

This study which assumes that compliance with work ethic will reduce the CWB at the workplace is aligned with Ambikai (2019) which implementation of strict laws and regulations in organizations as an effort to decrease deviant behaviour. Moreover, supposing that a university's ethics are determined by the opinions of its professors, administrative personnel, and students, which dictates immoral conduct that gets embedded in the organisational culture (Rothman, 2017). Furthermore, the study contributes to fostering employees' feelings of commitment towards the organization. It was agreed by a prior study that found a negative correlation between workplace deviance and ethical climates of independence, law and code, and norms, which in turn boost sentiments of commitment to the organization (Kaur, 2017). The contribution of the study also includes the perspective of emphasizing members of an organization that should be aware of work ethics since it can aid an effort to further human civilization in the organization (Abdullah & Halim, 2016). Additionally, this study contributes to the industry through managers can improve their understanding of managing and preventing workplace deviance by learning more about the causes of these behaviours (Harder, 2019).

References

- Abdullah, A., & Halim, F. wati. (2016). The Influence of Work Ethic and Counterproductive Work Behaviour of Civil Servants. *Journal of Technology Management and Business*, 03(01), 1–14.
- Adelstein, J., & Clegg, S. (2016). Code of Ethics: A Stratified Vehicle for Compliance. *Journal of Business Ethics*, 138(1), 53–66. <https://doi.org/10.1007/s10551-015-2581-9>
- Akbulut, Y., Dursun, Ö. Ö., Dönmez, O., & Şahin, Y. L. (2016). In search of a measure to investigate cyberloafing in educational settings. *Computers in Human Behavior*, 55, 616–625. <https://doi.org/10.1016/j.chb.2015.11.002>
- Akinbode, J. O., & Falola, H. O. (2015). Work Ethics and Employees' Job Performance. *Journal of Leadership, Accountability and Ethics*.
- Al-Nashash, H. M., Panigrahi, S. K., & Darun, M. R. Bin. (2018). Do Work Ethics Improves Employee Job Satisfaction? Insights from Jordanian Banks. *International Journal of Academic Research in Business and Social Sciences*, 8(11), 627–645. <https://doi.org/10.6007/ijarbss/v8-i11/4936>
- Ali, A. (1998). *Scalling Of Islamic Rork Ethic* (pp. 575–583).
- Ambikai, S. T. (2019). Antecedents that affect Deviant Behavior at Workplace in Malaysia. *International Journal of History and Scientific Studies*, 1(4), 1–7.
- Amin, S., Situngkir, S., & Mala Fithriani AIRA, D. (2021). Minimizing Workplace Deviant Behaviors through Workplace Spirituality and Organizational Commitment: A Case Study in Indonesia*. *Journal of Asian Finance*, 8(5), 1119–1128. <https://doi.org/10.13106/jafeb.2021.vol8.no5.1119>
- Andreoli, N., & Lefkowitz, J. (2009). Individual and Organizational Antecedents of Misconduct in Organizations. *Journal of Business Ethics*, 1–5. <https://www.jstor.org/stable/40295117>
- Anwar, N., Nik Mahmood, N. H., Yusliza, M. Y., Ramayah, T., Noor Faezah, J., & Khalid, W. (2020). Green Human Resource Management for organisational citizenship behaviour towards the environment and environmental performance on a university campus.

- Journal of Cleaner Production*, 256, 120401.
<https://doi.org/10.1016/j.jclepro.2020.120401>
- Appelbaum, S. H., Iaconi, G. D., & Matousek, A. (2007). Positive and negative deviant workplace behaviors: Causes, impacts, and solutions. *Corporate Governance*, 7(5), 586–598. <https://doi.org/10.1108/14720700710827176>
- Ashford, T., & Davis, L. (2006). Defining Professional Behavior: A Situational Look at Ethics in the Classrooms and Laboratories of American Colleges and Universities. *Proceedings of the 2006 InSITE Conference*. <https://doi.org/10.28945/2998>
- Bandura, A. (1991). *Self-Regulation-Core Emotional Intelligence Capacity-Control of Oneself by Oneself What is Self-Regulation Theory? The Psychology of Self-Regulation 8 Ways to Improve Self-Regulation*.
- Basu, K., & Palazzo, G. (2008). Literature Review of Corporate Social Responsibility. *CSR, Sustainability, Ethics and Governance*, 33(1). https://doi.org/10.1007/978-3-662-44997-4_2
- Baumann, N., Kaschel, R., & Kuhl, J. (2005). Striving for unwanted goals: Stress-dependent discrepancies between explicit and implicit achievement motives reduce subjective well-being and increase psychosomatic symptoms. *Journal of Personality and Social Psychology*, 89(5), 781–799. <https://doi.org/10.1037/0022-3514.89.5.781>
- Baumeister, R. F., Heatherton, T. F., & Tice, D. M. (1994). *Losing control: How and why people fail at Self - Regulation*.
- Bennett, R. J., Marasi, S., & Locklear, L. (2018). Workplace Deviance. *Oxford Research Encyclopedia of Business and Management*, c, 1–27.
<https://doi.org/10.1093/acrefore/9780190224851.013.111>
- Bennett, R. J., & Robinson, S. L. (2000). Development of a measure of workplace deviance. *Journal of Applied Psychology*, 85(3), 349–360. <https://doi.org/10.1037/0021-9010.85.3.349>
- Chirasha, V., & Mahapa, M. (2012). An Analysis of the Causes and Impact of Deviant Behaviour in the Workplace . The Case of Secretaries in State Universities. *Journal of Emerging Trends in Economics and Management Sciences (JETEMS)*, 3(5), 415–421.
- Cullen, J. B., & Victor, B. (1988). *The Organizational Bases of Ethical Work Climates*. 1–5.
- De Russy, C. (2003). Professional ethics begin on the college campus. *Chronicle of Higher Education*.
- Egidi, I. J., Okpa, j. T., & Akomaye, A. E. (2017). Working conditions and deviant behaviour of employees in the University of Calabar , Cross River State , Nigeria. *IOSR Journal Of Humanities And Social Science (IOSR-JHSS)*, 22(7), 74–83. <https://doi.org/10.9790/0837-2207147483>
- Ehrich, L. C., Cranston, N., Kimber, M., & Starr, K. (2012). (UN) ETHICAL PRACTICES AND ETHICAL DILEMMAS IN UNIVERSITIES : ACADEMIC LEADERS ' PERCEPTIONS Associate Professor Lisa Catherine Ehrich * School of Learning & Professional Studies Queensland University of Technology Victoria Park Road Kelvin Grove QLD 40. *International Studies in Educational Administration*, 2(40), 99–114.
- Elçi, M., & Alpkan, L. (2009). The impact of perceived organizational ethical climate on work satisfaction. *Journal of Business Ethics*, 84(3), 297–311.
<https://doi.org/10.1007/s10551-008-9709-0>

- Elci, M., & Yagmur, A. (2019). An empirical examination of the mediating roles of communication and ethical climate. *Research Journal of Business and Management*, 6(1), 9–23. <https://doi.org/10.17261/pressacademia.2019.1018>
- Eungoo, K., & Hwang, H.-J. (2023). How to Enhance an Employee's Organizational Citizenship Behavior (OCB) as a Corporate Strategy. *Journal of Industrial Distribution & Business*, 14(1), 29–37. <https://doi.org/10.13106/jidb.2023.vol14.no1.29>
- Farouk, S., & Jabeen, F. (2018). Ethical climate, corporate social responsibility and organizational performance: evidence from the UAE public sector. *Social Responsibility Journal*, 14(4), 737–752. <https://doi.org/10.1108/SRJ-01-2017-0002>
- Fox, S., & Spector, P. E. (2002). The 32 Items Counterproductive work behavior checklist (CWB-C). *Journal of Applied Psychology*, 5–6. <https://paulspector.com/assessments/pauls-no-cost-assessments/counterproductive-work-behavior-checklist-cwb-c/>
- Fujita, K. (2011). On conceptualizing self-control as more than the effortful inhibition of impulses. *Personality and Social Psychology Review*, 15(4), 352–366. <https://doi.org/10.1177/1088868311411165>
- Gestsdottir, S., & Lerner, R. M. (2008). Positive development in adolescence: The development and role of intentional self-regulation. *Human Development*, 51(3), 202–224. <https://doi.org/10.1159/000135757>
- Gruys, M. L., & Sackett, P. R. (2003). Investigating the dimensionality of counterproductive work behavior. *International Journal of Selection and Assessment*, 11(1), 30–42. <https://doi.org/10.1111/1468-2389.00224>
- Gwamanda, N., & Mahembe, B. (2023). A confirmatory factor analytic study of an ethical climate measure in Zimbabwe. *SA Journal of Human Resource Management*, 21, 1–9. <https://doi.org/10.4102/sajhrm.v21i0.2184>
- Harder, T. (2019). *Antecedents of Workplace Deviance*. https://commons.nmu.edu/celebration_student_scholarship/2/
- Hassan, C. R. C., Basha, O. ., & Hanafi, W. H. W. (2007). Perception of building construction workers towards safety, health and environment. *Journal of Engineering Science and Technology*, 2(3), 271–279.
- Heyneman, S. (2015). The Corruption of Ethics in Higher Education. *International Higher Education*, 62, 8–9. <https://doi.org/10.6017/ihe.2011.62.8530>
- Hidayah, Z., Ayuni, D., Minrohayati, Andriyansah, & Wibowo, M. (2023). Antecedents of Deviant Behaviour in Higher Education Institutions and Its Effects on Lecturers' Performance. *Nigerian Journal of Economic and Social Studies*, 65(1), 1–17.
- Hitt, W. D. (1990). *Ethics and leadership*. 333–337. https://doi.org/10.1007/978-94-007-7362-2_43
- Hsieh, H.-H., & Wang, Y.-D. (2016). Linking perceived ethical climate to organizational deviance: The cognitive, affective, and attitudinal mechanisms. *Journal of Business Research*. <https://doi.org/10.1016/j.jbusres.2016.01.001>
- Hsieh, H. H., & Wang, Y. De. (2016). Linking perceived ethical climate to organizational deviance: The cognitive, affective, and attitudinal mechanisms. *Journal of Business Research*, 69(9), 3600–3608. <https://doi.org/10.1016/j.jbusres.2016.01.001>
- Ibrahim, M., & Iqbal, M. (2015). *Causes and Consequences of Teachers' Deviance in Public Boys' High Schools in Khyber Pakhtunkhwa, Pakistan*. III(8), 258–275.
- Ishak, N. K., Haron, H., & Ismail, I. (2019). Examining Factors That Could Lead To Unethical Behaviour in Institutions of Higher Learning. *Journal of Governance and Integrity*, 3(1),

- 10–18. <https://doi.org/10.15282/jgi.3.1.2019.5418>
- Jamil, R., Mohammad, J., & Ramu, M. (2019). Antecedents of Unethical Behaviour Intention: Empirical Study in Public Universities in Malaysian Context. *Journal of Academic Ethics*, 17(1), 95–110. <https://doi.org/10.1007/s10805-018-9312-7>
- Jayabalan, P. (2013). Workplace Ethics: Ensuring harmony in the office. *My Star Job*. https://mystarjob.com/articles/story.aspx?file=/2013/2/2/mystarjob_careerguide/12606844&sec=mystarjob_careerguide (accessed December 5, 2021).
- Juras, A., Lovrinevic, M., & Kruzic, D. (2022). Implementing Organizational Ethics in an Academic Environment: The Case of a Croatian University. *Proceedings of the European Conference on Management, Leadership and Governance, 2022-Novem(2017)*, 211–221. <https://doi.org/10.34190/ecmlg.18.1.662>
- Kaur, J. (2017). Exploring relationships among ethical climate types and organizational commitment: A case of Indian banking sector. *Journal of Indian Business Research*. <https://www.emerald.com/insight/content/doi/10.1108/JIBR-02-2015-0022/full/html>
- Kidwell, R. E., Eddleston, K. A., & Kellermanns, F. W. (2018). Learning bad habits across generations: How negative imprints affect human resource management in the family firm. *Human Resource Management Review*, 28(1), 5–17. <https://doi.org/10.1016/j.hrmr.2017.05.002>
- Komari, N., & Djafar, F. (2013). Work Ethics, Work Satisfaction and Organizational Commitment at the Sharia Bank, Indonesia. *International Business Research*, 6(12). <https://doi.org/10.5539/ibr.v6n12p107>
- Leite, J. C., & Leonardi, M. C. (1998). Business rules as organizational policies. *Proceedings of the 9th International Workshop on Software Specification and Design, IWSSD 1998, June*, 68–76. <https://doi.org/10.1109/iwssd.1998.667921>
- Long, J., Johnson, C., & Faight, S. (2021). A case study in ethics, employee evaluation, and the promotion process. *Journal of Business Cases and Applications, Volume 32*. <http://www.aabri.com/copyright.html>
- Malik, P., & Lenka, U. (2018). Integrating antecedents of workplace deviance: utilizing AHP approach. *Journal of Indian Business Research*, 10. <https://doi.org/10.1108/JIBR-09-2017-0148>
- Mansoara, N., & Armanu, A. P. (2021). the Effect Between Ethical Climate and Organizational Culture on Deviant Behavior Through Organizational Commitment As a Mediation Variable (Studies on Civil Servants At the Regional Secretariat Manokwari Regency Government). *South East Asia Journal of Contemporary Business, Economics and Law*, 24(1), 1.
- McCornac, D. (2015). Corruption in Vietnamese Higher Education. *International Higher Education*, 50, 25–26. <https://doi.org/10.6017/ihe.2008.50.7992>
- Mirshekary, S., & Lawrence, A. D. K. (2009). Academic and business ethical misconduct and cultural values: A cross national comparison. *Journal of Academic Ethics*, 7(3), 141–157. <https://doi.org/10.1007/s10805-009-9093-0>
- Mount, M. K., & Johnson, E. (2006). RELATIONSHIP OF PERSONALITY TRAITS AND COUNTERPRODUCTIVE WORK BEHAVIORS: THE MEDIATING EFFECTS OF JOB SATISFACTION. *Article in Personnel Psychology*. <https://doi.org/10.1111/j.1744-6570.2006.00048.x>
- Mulki, J. P., Jaramillo, J. F., & Locander, W. B. (2008). Effect of ethical climate on turnover intention: Linking attitudinal- and stress theory. *Journal of Business Ethics*, 78(4), 559–574. <https://doi.org/10.1007/s10551-007-9368-6>

- Nazaar, M., Marican, S., Arshad, R., & Khalil, S. (1997). Etika Kerja dikalangan Kakitangan Sektor Awam. *Journal of Technology Management and Business*, 03(01).
- Obalade, G. O., & Arogundade, K. K. (2019). Ethical climate and deviant behavior among employees of selected public and private universities: The case of the emerging country. *Corporate Governance and Organizational Behavior Review*, 3(2), 30–39. https://doi.org/10.22495/cgobr_v3_i2_p3
- Oettingen, G. (1999). Expectancy effects on behavior depend on self-regulatory thought. *Social Cognition*, 18(2), 101–129. <https://doi.org/10.1521/soco.2000.18.2.101>
- Paine, L. S. (2010). The Globe: The China Rules. *Harvard Business Review*, 1–2. papers2://publication/uuid/D6AB954F-E97D-4669-8FE2-B3901E7A2BDE
- Preston, N., Samford, C., & Connors, C. (2002). *Encouraging ethics and challenging corruption*. [https://books.google.com.my/books?hl=en&lr=&id=jPx8mHwzc74C&oi=fnd&pg=PA3&dq=Preston,+N.+%26+Samford,+C.+with+Connors,+C.+\(2002\),+Encouraging+Ethics+and+Challenging+Corruption+\(Sydney:+The+Federation+Press\).&ots=SttrPSTnTO&sig=-gYLdoBd3HvXV1k4jffWejSscns&](https://books.google.com.my/books?hl=en&lr=&id=jPx8mHwzc74C&oi=fnd&pg=PA3&dq=Preston,+N.+%26+Samford,+C.+with+Connors,+C.+(2002),+Encouraging+Ethics+and+Challenging+Corruption+(Sydney:+The+Federation+Press).&ots=SttrPSTnTO&sig=-gYLdoBd3HvXV1k4jffWejSscns&)
- Prisacariu, A., & Shah, M. (2016). Defining the quality of higher of education around ethics and moral values. *Quality in Higher Education*. <https://www.tandfonline.com/doi/abs/10.1080/13538322.2016.1201931>
- Robbins, S. P., & Judge, T. A. (2009). *Organization Behaviour* (13th editi). Pearson. [https://books.google.com.my/books?hl=en&lr=&id=BzTiBAAQBAJ&oi=fnd&pg=PP1&dq=Robbins,+S.P.+%26+Judge,+T.A.+\(2009\).+Organization+Behavior+\(13th+ed\).+New+Jersey:+Pearson+Prentice+Hall.&ots=gT3x2z3ZTY&sig=-6Ojkh-zavNqUsztAvKONMwqqBk&redir_esc=y#v=onepage&q&f=](https://books.google.com.my/books?hl=en&lr=&id=BzTiBAAQBAJ&oi=fnd&pg=PP1&dq=Robbins,+S.P.+%26+Judge,+T.A.+(2009).+Organization+Behavior+(13th+ed).+New+Jersey:+Pearson+Prentice+Hall.&ots=gT3x2z3ZTY&sig=-6Ojkh-zavNqUsztAvKONMwqqBk&redir_esc=y#v=onepage&q&f=)
- Robinson, S. L., & Bennett, R. J. (1995). a Typology of Deviant Workplace Behaviors: a Multidimensional Scaling Study. *Academy of Management Journal*, 38(2), 555–572. <https://doi.org/10.2307/256693>
- Rothman, P. (2017). Ethics in higher education: A study of the perceived ethical climate of administrators and faculty at a higher education institution. *Education Doctoral*, 1–81. https://fisherpub.sjfc.edu/cgi/viewcontent.cgi?article=1290&context=education_etd%0Ahttps://fisherpub.sjfc.edu/education_etd/287
- Runtu, D., Aldrin, N., & Merdiaty, N. (2019). Effect of work ethics on job performance with adversity quotient as a mediator. *International Journal of Research in Business and Social Science (2147- 4478)*, 8(5), 98–103. <https://doi.org/10.20525/ijrbs.v8i5.457>
- Sackett, P.R. and Devore, C. J. (2001). Counterproductive Behaviors at Work. In Anderson, N., Ones, D., Sinangil, H. and Viswesvaran, C., Eds., *Handbook of Industrial, Work, and Organizational Psychology*, Sage, London, 145-164. - References - Scientific Res. In *Handbook of Industrial, Work, and Organizational Psychology* (pp. 145–164). [https://www.scirp.org/\(S\(351jmbntvnsjt1aadkposzje\)\)/reference/ReferencesPapers.aspx?ReferenceID=1419087](https://www.scirp.org/(S(351jmbntvnsjt1aadkposzje))/reference/ReferencesPapers.aspx?ReferenceID=1419087)
- Sapada, A. F. A., Modding, H. B., Gani, A., & Nujum, S. (2017). The Effect of Organizational Culture and Work Ethics on Job Satisfaction and Employees Performance. *The International Journal of Engineering and Science (IJES)*, 6(12), 28–36. <https://doi.org/10.9790/1813-0612042836>
- Sarwar, M., & Alam, M. (2010). *101201 Sarwar et al Location and Gender Differences*. 5(12), 97–101.
- SCHMINKE, M., ARNAUD, A., & KUENZI, M. (2007). The Power of Ethical Work Climates. *Organizational Dynamics*, 36(2), 171–186.

- <https://doi.org/10.1016/j.orgdyn.2007.03.005>
- Shacklock, A., Manning, M., & Hort, L. (2011). Ethical climate type, self-efficacy, and capacity to deliver ethical outcomes in public sector human resource management. *Journal Of New Business Ideas & Trends*, 29, 34–49.
<http://library.gcu.edu:2048/login?url=http://search.ebscohost.com/login.aspx?direct=true&db=bth&AN=71792639&site=eds-live&scope=site>
- Sharif, I. (2000). *Amalan kerja beretika di sektor awam: Kajian ke atas Jabatan Penilaian dan Perkhidmatan Harta*.
- Sheppes, G., Suri, G., & Gross, J. J. (2015). Emotion regulation and psychopathology. *Annual Review of Clinical Psychology*, 11(June 2016), 379–405.
<https://doi.org/10.1146/annurev-clinpsy-032814-112739>
- Soomro, S. A., Kundi, Y. M., & Kamran, M. (2020). Antecedents of Workplace Deviance: Role of Job Insecurity, Work Stress, and Ethical Work Climate. *Problemy Zarządzania - Management Issues*, 6/2019(86), 74–90. <https://doi.org/10.7172/1644-9584.86.4>
- Spector, P. E., & Fox, S. (2005). *The Stressor-Emotion Model of Counterproductive Work Behavior*. <https://psycnet.apa.org/record/2004-19514-007>
- Spector, P., Johnson, R., Spect, P., Bauer, J., Spector, P. E., Fox, S., Penney, L. M., Bruursema, K., Goh, A., Kessler, S., & Spector, P. E. (2006). The dimensionality of counterproductivity: Are all counterproductive behaviors created equal? *Journal of Vocational Behavior*, 68, 446–460. <https://doi.org/10.1016/j.jvb.2005.10.005>
- Tahir, I., Baloch, A., & Shujaat, S. (2018). *Factors Influencing Counterproductive Work Behaviour in Pakistani Organisations*. 1–17.
- Tayebiniya, N. K., & Khorasgani, N. S. (2018). The relationship between workplace spirituality and job performance among staff of Azad Islamic University, Iran. *Humanities and Social Sciences Reviews*, 6(1), 14–19. <https://doi.org/10.18510/hssr.2018.613>
- Thompson, M. (2011). Who Makes the Rules? Establishing Occupational Health and Safety Regulations. *International Journal of Contemporary Economics and Administrative Sciences*, 2, 79–89.
- Tokmak, M. (2020). A Study on the Relationship between Ethical Climate Perception and Innovative Work Behavior in Health Workers. *Anadolu Üniversitesi Sosyal Bilimler Dergisi*, 20(4), 51–64. <https://doi.org/10.18037/ausbd.845723>
- Valentine, S., & Barnett, T. (2013). Perceived Organizational Ethics and the Ethical Decisions of Sales and Marketing Personnel. <http://Dx.Doi.Org/10.2753/PSS0885-3134270407>, 27(4), 373–388. <https://doi.org/10.2753/PSS0885-3134270407>
- Vardi, Y. (2001). The Effects of Organizational and Ethical Climates on Misconduct at Work. *Journal of Business Ethics*, 325–337. <https://www.jstor.org/stable/25074466>
- Wheeler, H. N. (1976). Punishment Theory and Industrial Discipline. *Industrial Relations: A Journal of Economy and Society*, 15(2), 235–243. <https://doi.org/10.1111/J.1468-232X.1976.TB01120.X>
- Yahya, O., Salamun, N. A., Shaari, A. N., & Abdul Wahab, J. (2011). *Tahap Amalan Pengurusan Sumber Manusia dan Kepuasan Guru di Sekolah Rendah Agama Negeri Selangor*. *Jurnal Pendidikan dan Latihan*. 3(1),57-72.
- Yousef, D. A. (2001). Islamic Work Ethic: A Moderator between Organizational Commitment and Job Satisfaction in a Cross-Cultural Context. *Article in Personnel Review*. <https://doi.org/10.1108/00483480110380325>
- Yunus, O. M., Abdul Rahim, Abdul Rahman Shabuddin, A., & Mazlan, M. (2011). *WORK ETHIC OF MALAYSIAN CIVIL SERVANTS*.

- Zulkeflee, A. A., Faisal, N., Ismail, F., & Ismail, N. A. (2020). Case Studies on The Current Safety Issue And Work Behaviour of Construction Site Workers In Malaysia. *International Journal of Accounting, Finance and Business*.
- Zvavahera, P., Chigora, F., & Kembo, S. (2021). Work ethics and industrial relations in higher education institutions. *Journal of Applied Management and Investments*, 10(2), 67–78.