

Measurement Model of Input Constructs for the Implementation of Dual Language Programme (DLP)

Nazariyah Jonid, Mohd Effendi @ Ewan Mohd Matore

Faculty of Education, National University of Malaysia, Selangor, Malaysia

Email: p120739@siswa.ukm.edu.my, effendi@ukm.edu.my

To Link this Article: <http://dx.doi.org/10.6007/IJARBSS/v14-i5/21461>

DOI:10.6007/IJARBSS/v14-i5/21461

Published Date: 07 May 2024

Abstract

The Dual Language Program (DLP) in Malaysia, which is dual language education program, is an initiative introduced to enhance English language proficiency while maintaining Malay as the national language. The principle is to provide instruction in two languages, with Malay as the medium of instruction and English as the second language. However, there is limited empirical evidence discussed regarding the measurement aspects for assessing input factors for the DLP implementation. Therefore, this study was conducted to validate the measurement model assessing input factors for the implementation of the DLP. A total of 432 teachers participated using simple random sampling. The variables focused in this study are input factors for implementation of the DLP. Data were tested using exploratory factor analysis (EFA) to measure items and determine the dimensions of the DLP input construct, while confirmatory factor analysis (CFA) was used to validate the instrument. The EFA findings indicate three dimensions exist within the DLP input construct: resources, teacher knowledge, and teacher skills. The CFA findings on the measurement model indicate that the three-factor solution is consistent and acceptable for suggested indicators. Therefore, the development of 18-item model is suitable for assessing the input factors of DLP. The implications of this study enhance understanding of the validity and reliability aspects of items for DLP measurement in the local context. Further research could be conducted using analyses such as Item Response Theory or Rasch model analysis.

Keywords: DLP, EFA, CFA, Assessment, Input Factors.

Introduction

Dual Language Programme (DLP) is a program introduced under the Enhancing Malay Language, Strengthening English Language Policy (MBMMBI) offer schools that meets certain criteria to conduct teaching and learning sessions entirely in English for Science, Technology, Engineering, and Mathematics (STEM) subjects (MoE, 2017). The DLP was implemented in

2016 after the announcement by the Prime Minister of Malaysia on October 23, 2015, with the authority for implementation through the MoE Circular Letter No. 18 of 2015.

The implementation of DLP aims to support students' mastery of English language skills through increased exposure to the English language in science and mathematics subjects. By strengthening a student's bilingualism, the DLP provides opportunities for students to enhance access, explore various fields of knowledge to compete globally, and improve their employability (MoE, 2015). Therefore, for schools choosing to participate in the DLP, all four criteria set by the KPM must be met, which are (i) have sufficient resources, (ii) Principal willing to implement the DLP, (iii) obtain requests and support from parents, and (iv) the school's achievement in Malay language is equivalent to or better than the national average Malay language achievement (MoE, 2015; MoE, 2017; Shamsudin et al., 2018; Masrom et al., 2021). Assessment provides an interpretation of the strengths and weaknesses of each dimension tested, and the success of the program depends on decisions made based on all program aspects. Input is related to the system's ability to develop a program, especially concerning expenditure. Therefore, the assessment of input factors for the implementation of DLP needs attention as it is a factor enabling the ministry to take appropriate action for program improvement. Thus, the study aims to develop and validate instruments to measure input constructs in the DLP.

Literature Review

DLP's Input Factor

Stufflebeam (1983) states that assessment is conducted to provide information on how resources should be used to achieve the objectives of a program. These input or resources encompass human resources as well as physical resources. Therefore, in the context of this study, the human resources assessed include the knowledge and skills of the teachers, while the physical resources refer to reference materials, classrooms, facilities, and internet access that can be used to support the more effective implementation of the DLP.

Initiated in 2016, the current scenario of DLP implementation still faces widespread controversy even after eight years of implementation, as it is alleged to be unable to solve the problem of English language proficiency (Ismail, 2023). The lack of English language proficiency among teachers will hinder the effective implementation process of the DLP, given that teachers play a crucial role in ensuring the smooth running of any program (Mahmud et al., 2018). Furthermore, Yunus & Sukri (2017) also emphasized that 25 percent of teachers nationwide are not proficient in teaching Science and Mathematics using English as the medium of instruction. The same situation can be observed when teachers who are not proficient in English face difficulties in implementing the DLP due to the use of English as the primary medium of instruction and communication (Suliman et al., 2019). Students' knowledge and learning results are negatively impacted by scientific teachers' incapacity to teach science in English (Mahmud et al., 2018). Therefore, the problems and difficulties mentioned suggest that teacher competence, particularly in terms of knowing the English language, is essential to guaranteeing the DLP's seamless implementation and attaining the intended objectives.

The continuity of the DLP learning process in schools is also disrupted by inadequate reference materials and available resources, in addition to knowledge and skills (Suliman et al., 2019). According to Moses & Malani (2019), most schools lacked the necessary supplies and equipment to conduct DLP classes. Additionally, physical resources, such as infrastructure and equipment allow for the efficient implementation of teaching and learning (Ghani & Nor,

2020). In light of the aforementioned issues and challenges, it is discovered that aspects of knowledge, skills, and resources are crucial DLP input indications that require careful consideration in order to guarantee the success of DLP implementation in educational settings.

Exploratory Factor Analysis

The main purposes of exploratory factor analysis (EFA) are to determine a measure's factor structure and assess its internal reliability. In order to minimize variance differences and determine the amount of items required for each variable component, EFA is carried out in the instrument before the factor validation procedure (Nasir et al., 2020; Yaakob & Yunus, 2016). To determine an appropriate structural form, several statistical variables in the factor analysis results are evaluated. The Kaiser-Meyer-Olkin (KMO) measure, Bartlett's Test of Sphericity, eigenvalues, factor loadings, percentage of explained variance, and the number of items representing each factor are examples of commonly used indicators. The typical indicators are as follows:

- (a) KMO values more than 0.80 are considered excellent; 0.70 are commendable; 0.60 are above average; 0.50 are average; and values below 0.50 are unacceptable for conducting factor analysis (Hair et al., 2010).
- (b) A p-value less than 0.05 in *Bartlett's Test of Sphericity* indicates that the variables are independent and suitable for factor analysis (Meyers et al., 2006; Hair et al., 2010).
- (c) Eigenvalues greater than one are significant for each factor (Meyers et al., 2006; Hair et al., 2010).
- (d) The percentage of explained variance must be at least 60 percent of the total variance (Meyers et al., 2006).
- (e) Significant factor loadings must be 0.3 and above (Hair et al., 2010). Items with factor loadings less than 0.3 or with cross-loadings are not retained.

Confirmatory Factor Analysis

Confirmatory factor analysis (CFA) is used to validate factor loadings and measurements involved in the study (Baistaman et al., 2020). High factor loadings are insufficient for acceptance unless fitness indices are met. Three categories of fitness indices evaluated are *parsimonious fit*, *absolute fit*, and *incremental fit* (Awang et al., 2018). Researchers are entitled to choose any fitness index as per the recommendation that the use of at least one fitness index represents model adequacy (Dalila et al., 2020; Hair et al., 2010; Byrne, 2010). Table 1 shows the acceptance level values for fitness indices in CFA consideration.

Table 1
Categories and Acceptance Levels of Fitness Indices

Category	Indices	Acceptance Level
<i>Absolute Fit</i>	Chisq	p > 0.05
	RMSEA	RMSEA < 0.08
	GFI	GFI > 0.90
<i>Incremental Fit</i>	AGFI	AGFI > 0.90
	CFI	CFI > 0.90
	TLI	TLI > 0.90
	NFI	NFI > 0.90
<i>Parsimonious Fit</i>	Chisq/df	Chisq/df < 5.0

Source: Kline (2005); Hair et al (2006)

Modifications to the model can be made following the guidelines of Hair et al. (2006) by examining several pieces of information, such as:

- (a) Factor loadings and *Squared Multiple Correlation* (SMC) of each item must exceed the recommended values (0.5 and 0.3 respectively),
- (b) *Standard residuals* between 2.58 to 4.00 are considered for retention or removal, while values exceeding 4.00 must be removed, and
- (c) Modification index is used to improve the model (Hair et al., 2006; Byrne, 2010; Kline, 2005).

Methodology

This study employs a quantitative research design of survey type. The population for this study consists of teachers who teach subjects in the fields of science and mathematics for DLP classes in Malaysia. In the context of this study, the sample size is 432 teachers. According to Krejcie & Morgan (1970), the sample size if the population exceeds 100,000 is 384 and above, which also aligns with the suggestion that a sample size ranging from 30 to 500 is suitable for most studies (Roscoe, 1975; Sekaran & Bougie, 2016).

The survey instrument for this study was constructed through the modification of Shamsudin et al.'s (2018) instrument and improvements by the researcher based on the assessment objectives related to the implementation of DLP using the CIPP assessment model (context, input, process, product). However, the researcher only focused on the input construct for the purpose of analysis, which includes (i) exploratory factor analysis (EFA), (ii) confirmatory factor analysis (CFA), and (iii) model fit. The researcher utilized EFA by selecting the principal method through varimax rotation as suggested by Hair et al (2006) and used goodness-of-fit values for CFA.

Results and Discussion

The reliability of the DLP input construct is determined by the Cronbach's Alpha value. The analysis results indicate that the Cronbach's Alpha value for the DLP input construct containing 20 items is $\alpha = 0.736$. According to Pallant (2010), constructs with Cronbach's Alpha values of 0.60 and above are acceptable, supported by Babbie's (1992) classification of Cronbach's Alpha values of 0.70 - 0.89 as high reliability. Thus, this value indicates that the DLP implementation input construct meets high internal consistency standards and has excellent reliability, making it suitable for actual studies (Cronbach, 1951; Hair et al., 2017).

The EFA findings provide several clues to obtain a suitable structural form. The obtained *Kaiser-Meyer-Olkin* (KMO) value of 0.875 is excellent according to Hair et al. (2010) and indicates that the sample size is sufficient for the 20-item scale. Additionally, the p-value of *Bartlett's Test of Sphericity* approaching zero concludes the adequacy of this data for factor analysis. However, the researcher dropped two items when the *Rotated Component Matrix* findings showed that these two items were placed in the fourth component, not meeting the minimum requirement of 3 items in one construct. EFA analysis was conducted once again, resulting in a new KMO value of 0.873 as shown in Figure 1.

Kaiser-Meyer-Olkin Measure of Sampling Adequacy.		.873
Bartlett's Test of Sphericity	Approx. Chi-Square	3660.599
	df	153
	Sig.	<.001

Figure 1. Kaiser-Meyer-Olkin (KMO) dan Barlett's Test of Sphericity Output

The Scree Plot graph in Figure 2 shows that there are 3 components emerging for the 18 DLP input items based on Eigen values exceeding 1.0. The Eigen values and the percentage of variance explained for each component are presented in Table 2. The obtained Eigen values range between 5.957 and 1.221; the variance explained for component 1 is 33.092%, component 2 is 18.034%, and component 3 is 11.864%. The total variance explained to measure this construct is 62.990%. This value meets the minimum requirement of 60% (Pallant, 2016; Meyers et al., 2006).

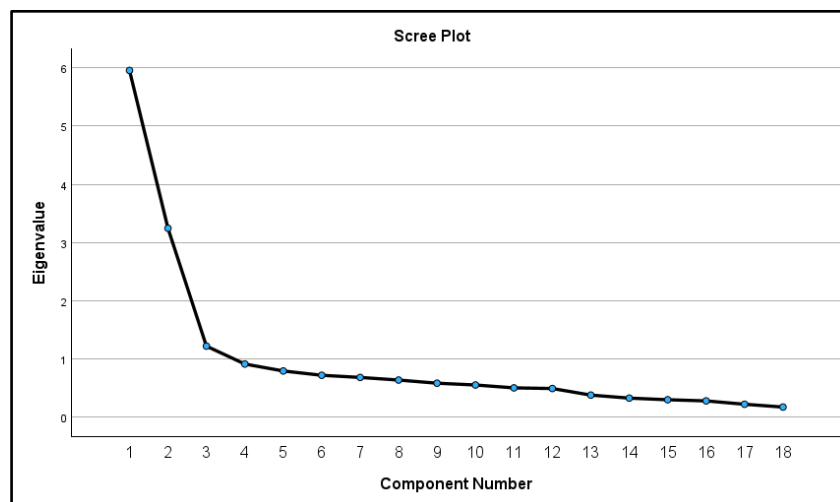

Figure 2. Scree Plot Graph

Table 2

Total Variance Explained for Each Component

Component	Eigen Values		
	Total	Variance Explained (%)	Cumulative Variance Explained (%)
1	5.957	33.092	33.092
2	3.246	18.034	51.126
3	1.221	11.864	62.990

The findings in Table 3 below indicate that all items have factor loadings ranging from 0.532 to 0.851. These obtained values align with the perspective of Hair et al. (2010) that factor loadings should be 0.3 and above. Therefore, in the context of this study, all 18 items in the assessment of the DLP implementation input construct can be accepted. Component 1 consists of ten items, component 2 consists of four items, and component 3 consists of four items. The total number of retained items is 18 out of the original 20 proposed items. The two

dropped item statements are 'the exposure given to me is sufficient' and 'the concept of DLP is very easy to understand'.

Table 3

Rotated Component Matrix for the DLP Input Construct

Rotated Component Matrix^a

Items	Component		
	1	2	3
The science laboratory is equipped with sufficient equipment.	.818		
Teaching aids provided are suitable for contemporary learning.	.763		
Good internet access is available to support learning.	.745		
Discussion spaces are provided in the school.	.727		
The computer laboratory provided is sufficient and usable.	.700		
Reference materials on DLP have been distributed to each school.	.676		
The DLP guidebook helps me in learning the system.	.667		
New books related to DLP are available in the resource center.	.627		
Classrooms are conducive to DLP class learning.	.621		
DLP reference materials are easily accessible.	.543		
I have good instructional knowledge in teaching DLP.		.851	
I know how to record student work results in DLP implementation.		.851	
DLP enhances my knowledge to teach science and mathematics subjects.		.790	
I know and understand scientific or mathematical terms in English.		.659	
I can explain the process of science or mathematics in English well.			.830
I always use English when discussing with students in class.			.771
I can speak English well.			.579
I can question well in English.			.532

The researcher once again tested the reliability of the construct based on Cronbach's Alpha values for the three components summarized as resources, teacher knowledge, and teacher skills. A summary of Cronbach's Alpha for each component is presented in Table 4. The obtained Cronbach's Alpha values range from 0.799 to 0.881, falling within the classification of high reliability indices (0.70 - 0.89) and indicating that the DLP implementation input construct meets high internal consistency standards and has excellent reliability, making it suitable for actual studies (Hair et al., 2017; Pallant, 2010; Babbie, 1992; Cronbach, 1951).

Table 4

Cronbach's Alpha for Each Component

Component	Number of Item	Cronbach's Alpha Value
Resources	10	0.881
Teacher Knowledge	4	0.852
Teacher Skills	4	0.799

Confirmatory Factor Analysis (CFA) was used for the 18 items that were validated following the EFA analysis to determine the assessment of DLP implementation input. The CFA

procedure was conducted using IBM SPSS AMOS 28 Graphics, and the analysis results are presented as shown in Figure 3.

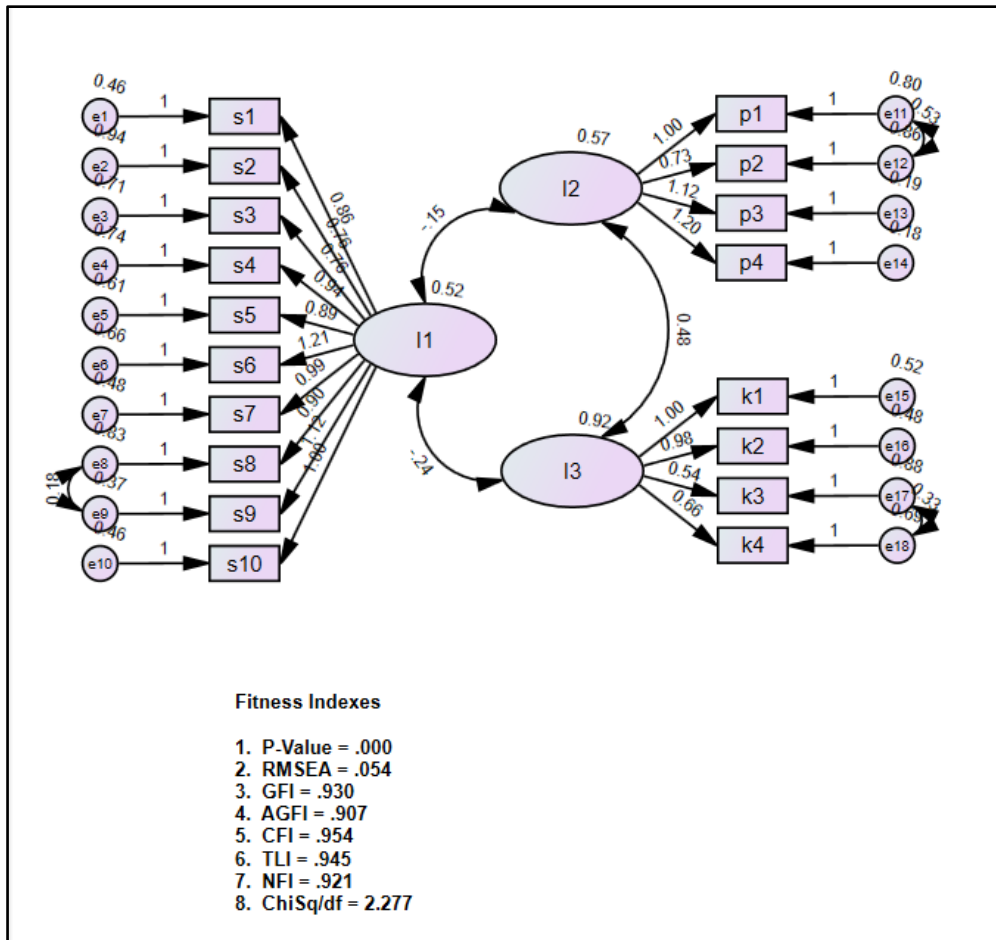

Figure 3. Confirmatory Factor Analysis (CFA) Output

The DLP input assessment model was tested by examining fit indices as suggested, and the summary is presented in Table 5.

Table 5
Results of Fitness Index Analysis

Category	Index	Acceptance Level	Results
<i>Absolute Fit</i>	Chisq	>	0.05 Chisq = 0.000
	RMSEA	<	0.08 RMSEA = 0.054
	GFI	> 0.90	GFI = 0.930
<i>Incremental Fit</i>	AGFI	> 0.90	AGFI = 0.907
	CFI	> 0.90	CFI = 0.954
	TLI	> 0.90	TLI = 0.945
	NFI	> 0.90	NFI = 0.921
<i>Parsimonious Fit</i>	Chisq/df	<3.0 (Awang et al.,2018; Pallant, 2016)	Chisq/df= 2.277

Based on Table 5, the researcher obtained fit indices encompassing both absolute fit and incremental fit at acceptable levels. The researcher also obtained a ChiSq/df value < 3.0,

indicating a good level of fit (Pallant, 2016). Therefore, the validity of the 18-item DLP input assessment construct is confirmed.

Conclusion

The Malaysia Ministry of Education (KPM) should consider the proposed improvements to ensure the sustainability and continuity of the DLP program in the future. With the Malaysia Education Blueprint nearing its completion by the year 2025, KPM needs to seize this opportunity to reassess the direction of the country's education and take proactive improvement measures to prevent the mistakes made in the implementation of Teaching and Learning of Science and Mathematics in English (PPSMI) from recurring. The implementation of DLP is seen as an opportunity to enhance English language proficiency not only for teachers but also for students. Therefore, the implications of DLP also bring about changes to the classroom environment, making it more active and enjoyable, where students can learn not only using their mother tongue but also simultaneously develop their potential to master English, which is recognized as the primary language of global communication.

Hence, to ensure the quality of DLP implementation is at a good level, the roles and responsibilities of all parties are needed, starting from grassroots to the highest levels. Administrators should have good relations with the ministry and local communities so that parents can understand the government's direction regarding the DLP program. Therefore, all parties must work together to shoulder this responsibility and hope that Malaysian education can compete with other advanced countries internationally. In conclusion, this study has conducted validity and reliability procedures on the instrument focusing on the assessment input construct of DLP implementation. The research findings indicate high validity and reliability. Therefore, the assessment input construct instrument of DLP implementation has undergone instrument adaptation processes and is suitable for use in the Malaysian education context.

The theoretical contribution of this study incorporates dynamic assessments that evaluate the efficiency of resources and the execution skills of DLP. The measurement of DLP input constructs can provide a valid and reliable model, as well as a solid foundation for future research and applications. Additionally, this study contributes to the improvement of better DLP instruments, which involve input constructs. Longitudinal assessments conducted on DLP inputs can contribute to the use of valid instruments in enhancing the effectiveness of DLP interventions and making decisions to foster a supportive learning environment based on that data. Meanwhile, the contextual contributions of this study include informing policymakers about necessary adjustments to better support bilingual education. Besides allocating resources more effectively, supporting the development and guidance of DLP implementation mechanisms can contribute to the evolution and improvement of bilingual education practices.

Corresponding Author

Mohd Effendi @ Ewan Mohd Matore (Ph. D)

Faculty of Education, National University of Malaysia, 43600 UKM Bangi, Selangor, Malaysia.

Email: effendi@ukm.edu.my

References

- Awang, Z., Lim, S. H., and Zainudin, N. F. S. (2018). *Pendekatan mudah SEM- Structural Equation Modelling*. MPWS Rich Resources.
- Babbie, E. (1992). *The practice of social research*. Wardsworth Publishing Company.
- Baistaman, J., Awang, Z., Afthanorhan, A., & Abdul Rahim, M. Z. (2020). Developing and validating the measurement model for financial literacy construct using confirmatory factor analysis. *Humanities & Social Sciences Reviews*, 8(2), 413-422.
- Bryne, B. M. (2010). *Structural Equation Modeling with AMOS: Basic concepts, applications and programming*. Lawrence Erlbaum Associates Publishers.
- Bullah, N. B. H., & Yunus, M. M. (2019). Teachers perception on the implementation of Dual Language Programme (DLP) in urban schools. *Asian Social Science*, 15(1), 24–31.
- Cronbach, L. J. (1951). Coefficient alpha and the internal structure of tests. *Psychometrika*, 16, 297 – 334.
- Dalila, Latif, H., Jaafar, N., Aziz, I., & Afthanorhan, A. (2020). The mediating effect of personal values on the relationships between attitudes, subjective norms, perceived behavioral control and intention to use. *Management Science Letters*, 10 (1), 153-162.
- Ghani, R. A., & Nor, M. M. (2020). Faktor yang mempengaruhi peranan guru dalam pelaksanaan Kurikulum Standard Prasekolah Kebangsaan (KSPK) di Malaysia. *JuKu: Jurnal Kurikulum & Pengajaran Asia Pasifik*, 8(4), 35-49.
- Hair, J. F., Black, W. C., Babin, B. J., Anderson, R. E., & Tatham, R. L. (2006). *Multivariate data analysis with reading*. Prentice Hall.
- Hair, J. F., Black, W. C., Babin, B. J., & Anderson, R. E. (2010). *Multivariate data analysis* (7th ed.). Pearson Education Inc.
- Hair, J. F., Jr., Babin, B. J., & Krey, N. (2017). Covariance-based structural equation modeling in the Journal of Advertising: Review and recommendations. *Journal of Advertising*, 46 (1), 163–177.
- Ismail, S. (2023). Keberkesanan DLP dipersoal. *Berita Harian*. <https://www.bharian.com.my/berita/pendidikan/2023>
- Kline, R. B. (2005). *Principles and practice of structural equation modeling*. (2nd ed.). The Guilford Press.
- Krejcie, R. V., & Morgan, D. W. (1970). Determining sample size for research activities. *Educational and Psychological Measurement*, 38 (1), 607–610. <http://doi.org/10.1177/001316447003000308>
- Mahmud, S. N. D., Nasri, N. M., Samsudin, M. A., & Halim, L. (2018). Science teacher education in Malaysia: challenges and way forward. *Asia Pacific Science Education*, 4, 8. <https://doi.org/10.1186/s41029-018-0026-3>
- Masrom, U. K., Idris, M., & Jusoh, Z. (2021). Dual Language Programme (DLP): Mediating effects of readiness, interest and confidence on students' satisfaction. *Journal of Nusantara Studies*, 6(2), 1 – 20.
- Meyers, L. S., Gamst, G., & Guarino, A. J. (2006). *Applied multivariate research: Design and interpretation*. SAGE Publication Ltd. page 675.
- Ministry of Education [MoE]. (2015). Circular Letter No. 18 of 2015: Pilot implementation of bilingual program or Dual Language Programme (DLP) at school in 2016.
- MoE. (2017). National Education Policy. 4th Edision.
- Yaakob, M. F. M., & Yunus, J. N. (2016). Model pengukuran kompetensi kerja guru. *Proceeding of International Consortium of Education and Culture Research Studies (ICECRS)*, 1, 13-20.

- Moses, E., & Malani, I. (2019). Dual Language Programme: The perceptions and challenges of teachers and students in Klang, Selangor. *Jurnal Pendidikan Sains dan Matematik Malaysia*, 9 (1), 36-48.
- Nasir, M. N. M., Mohamad, M., Ghani, N. I. A., & Afthanorhan, A. (2020). Testing mediation roles of place attachment and tourist satisfaction on destination attractiveness and destination loyalty relationship using phantom approach. *Management Science Letters*, 10(2), 443-454. <https://doi.org/10.5267/j.msl.2019.8.026>
- Pallant, J. (2010). *SPSS survival manual: A step by step guide to data analysis using SPSS* (4th ed.). Allen & Unwin.
- Pallant, J. (2016). *SPSS survival manual: A step by step guide to data analysis using SPSS* (6th ed.). Mc Graw Hill Education
- Roscoe, J. T. (1975). *Fundamental research statistics for the behavioural sciences* (2nd ed.). Holt Rinehart & Winston.
- Shamsudin, N., Abdullah, N., & Noh, M. N. (2018). Kesiediaan guru sains sekolah rendah terhadap pelaksanaan Dual Language Programme (DLP). *Jurnal Pendidikan Sains & Matematik Malaysia*, 8(1), 34 – 45.
- Sekaran, U., & Bougie, R. (2016). *Research methods for business: A skill-building approach* (7th. Ed.). John Wiley & Sons Ltd. UK.
- Stufflebeam, D. L. (1983). The CIPP model for program evaluation. In *Evaluation Models*. Kluwer-Nijhoff.
- Suliman, A., Nor, M., & Yunus, M. (2019). Sustaining the implementation of Dual-Language Programmes (DLP) in Malaysian secondary schools. *Global Journal of Business Social Science Review*, 7 (1), 91–97.
- Yunus, M. M., & Sukri, S. I. A. (2017). The use of English in teaching Mathematics and Science: The PPSMI policy vis-à-vis the DLP. *Advances in Language and Literary Studies*, 8(1), 133-142.